

Bourdon tube pressure gauge, stainless steel

Compact version, NS 40 [1 ½"], 50 [2"] and 63 [2 ½"]

Model 131.11

WIKA data sheet PM 01.05



For further approvals,
see page 5

Applications

- For gaseous and liquid aggressive media that are not highly viscous or crystallising, also in aggressive environments
- Machine building and general plant construction
- Indication of failure alarm on gas cylinders
- CDA (Clean Dry Air) applications

Special features

- Case and wetted parts from stainless steel
- Version per EN 837-1 or ASME B40.100
- Cost-effective and reliable
- Scale ranges from 0 ... 1 to 0 ... 1,000 bar [0 ... 15 to 0 ... 15,000 psi]



Bourdon tube pressure gauge model 131.11.050 with dual scale bar/psi

Configurator



Standard articles



Description

The compact model 131.11 Bourdon tube pressure gauge is constructed with a case and wetted parts from stainless steel.

The modular design enables a multitude of combinations of process connections, nominal sizes and scale ranges. Due to this high variance, the instrument is suitable for use in a wide range of applications within industry.

The instrument is frequently used as a failure alarm indicator on gas cylinders. With its compact design and moderate purchase costs, the pressure gauge also qualifies for machine-building and plant-construction applications.

Due to the use of high-quality stainless steel materials and its robust design, the instrument is suitable for liquid and gaseous media, also in aggressive environments.

For mounting in control panels, the pressure gauges can be fitted with a surface mounting flange or with a triangular profile ring and mounting bracket.

Specifications

Basic information					
Standard	<ul style="list-style-type: none"> ■ EN 837-1 ■ ASME B40.100 <p>→ For information on the "Selection, installation, handling and operation of pressure gauges", see technical information IN 00.05.</p>				
Special design feature	<ul style="list-style-type: none"> ■ Oil- and grease-free ■ For oxygen, oil- and grease-free ¹⁾ ■ Silicone-free ■ Version for ammonia plants <p>With temperature scale for refrigerant R 717 (NH₃) in °C Scale range: -1 ... 0 ... 15 bar or -1 ... 0 ... 26 bar</p>				
Nominal size (NS)	<ul style="list-style-type: none"> ■ Ø 40 mm [1 ½"] ■ Ø 50 mm [2"] ■ Ø 63 mm [2 ½"] 				
Connection location	<ul style="list-style-type: none"> ■ Lower mount (radial) ■ Centre back mount 				
Window	<ul style="list-style-type: none"> ■ Polycarbonate, snap-fitted in case ■ Laminated safety glass ²⁾ ■ Instrument glass ²⁾ 				
Case					
Design	<table border="0"> <tr> <td style="padding-right: 20px;">Lower mount (radial)</td> <td>Safety level "S1" per EN 837-1: With blow-out device at case circumference, 6 o'clock</td> </tr> <tr> <td>Centre back mount</td> <td> <ul style="list-style-type: none"> ■ Safety level "S0" per EN 837-1 ■ Safety level "S1" per EN 837-1: With blow-out device in case back </td> </tr> </table>	Lower mount (radial)	Safety level "S1" per EN 837-1: With blow-out device at case circumference, 6 o'clock	Centre back mount	<ul style="list-style-type: none"> ■ Safety level "S0" per EN 837-1 ■ Safety level "S1" per EN 837-1: With blow-out device in case back
Lower mount (radial)	Safety level "S1" per EN 837-1: With blow-out device at case circumference, 6 o'clock				
Centre back mount	<ul style="list-style-type: none"> ■ Safety level "S0" per EN 837-1 ■ Safety level "S1" per EN 837-1: With blow-out device in case back 				
Material	Stainless steel				
Ring	<ul style="list-style-type: none"> ■ Without ■ Slip-on bezel, stainless steel ■ Slip-on bezel, stainless steel, polished 				
Mounting	<ul style="list-style-type: none"> ■ Without ■ Panel mounting flange, polished stainless steel ³⁾ ■ Triangular profile ring with mounting bracket, polished stainless steel ³⁾ ■ Surface mounting flange, stainless steel ⁴⁾ 				
Movement	Stainless steel				

1) Not available for NS 63 [2 ½"]

2) Only available with slip-on bezel

3) Only available with centre back mount

4) Only available for NS 63 [2 ½"]

Measuring element	
Type of measuring element	Bourdon tube, C-type or helical type
Material	Stainless steel 1.4404 (316L)
Leak tightness	Helium tested, leakage rate: < 5 · 10 ⁻³ mbar l/s

Accuracy specifications	
Accuracy class	
<ul style="list-style-type: none"> ■ EN 837-1 	<ul style="list-style-type: none"> ■ Class 2.5 ■ Class 1.6
<ul style="list-style-type: none"> ■ ASME B40.100 	<ul style="list-style-type: none"> ■ ±3 % of measuring span (grade B) ■ ±2 % of measuring span (grade A)
Temperature error	On deviation from the reference conditions at the measuring system: ≤ ±0.4 % per 10 °C [≤ ±0.4 % per 18 °F] of full scale value
Reference conditions	
Ambient temperature	+20 °C [68 °F]

Scale ranges, gauge pressure

bar	
0 ... 1	0 ... 40
0 ... 1.6	0 ... 60
0 ... 2	0 ... 70
0 ... 2.5	0 ... 100
0 ... 4	0 ... 140
0 ... 6	0 ... 160
0 ... 7	0 ... 200
0 ... 10	0 ... 250
0 ... 14	0 ... 315
0 ... 16	0 ... 400
0 ... 20	0 ... 600
0 ... 25	0 ... 700 ¹⁾
0 ... 30	0 ... 1,000 ¹⁾

kPa	
0 ... 100	0 ... 4,000
0 ... 160	0 ... 6,000
0 ... 200	0 ... 7,000
0 ... 250	0 ... 8,000
0 ... 300	0 ... 10,000
0 ... 400	0 ... 14,000
0 ... 600	0 ... 16,000
0 ... 700	0 ... 20,000
0 ... 800	0 ... 25,000
0 ... 1,000	0 ... 40,000
0 ... 1,400	0 ... 60,000
0 ... 1,600	0 ... 70,000 ¹⁾
0 ... 2,500	0 ... 80,000 ¹⁾
0 ... 3,000	0 ... 100,000 ¹⁾

1) Only available for NS 63 [2 ½"]

Vacuum and compound scale ranges

bar	
-1 ... 0	-1 ... +7
-1 ... +0.6	-1 ... +9
-1 ... +1	-1 ... +10
-1 ... +1.5	-1 ... +15
-1 ... +3	-1 ... +25
-1 ... +5	-1 ... +30

kPa	
-100 ... 0	-100 ... +700
-100 ... +60	-100 ... +900
-100 ... +100	-100 ... +1,000
-100 ... +150	-100 ... +1,500
-100 ... +200	-100 ... +2,400
-100 ... +500	-100 ... +3,000

psi	
0 ... 15	0 ... 800
0 ... 30	0 ... 1,000
0 ... 60	0 ... 1,500
0 ... 100	0 ... 2,000
0 ... 150	0 ... 3,000
0 ... 160	0 ... 4,000
0 ... 200	0 ... 5,000
0 ... 250	0 ... 6,000
0 ... 300	0 ... 7,500
0 ... 400	0 ... 10,000 ¹⁾
0 ... 500	0 ... 15,000 ¹⁾
0 ... 600	-

MPa	
0 ... 0.1	0 ... 4
0 ... 0.16	0 ... 6
0 ... 0.20	0 ... 7
0 ... 0.25	0 ... 10
0 ... 0.4	0 ... 14
0 ... 0.6	0 ... 16
0 ... 0.7	0 ... 20
0 ... 1.0	0 ... 25
0 ... 1.4	0 ... 31.5
0 ... 1.6	0 ... 40
0 ... 2	0 ... 60
0 ... 2.5	0 ... 70 ¹⁾
0 ... 3	0 ... 100 ¹⁾

Further details on: Scale ranges	
Unit	<ul style="list-style-type: none"> ■ bar ■ psi ■ kPa ■ MPa ■ kg/cm²
Vacuum resistance	<ul style="list-style-type: none"> ■ Without ■ Vacuum-resistant to -1 bar
Dial	
Scale colour	Black
Material	Aluminium
Customer-specific version	<ul style="list-style-type: none"> ■ Without ■ With temperature scale for refrigerant, e.g. for NH₃: R 717 <p>Other scales or customer-specific dials, e.g. with red mark, circular arcs or circular sectors, on request → Alternatively, adhesive label set for red and green circular arcs; see data sheet AC 08.03</p>
Pointer	Aluminium, black
Pointer stop pin	<ul style="list-style-type: none"> ■ Without ■ At zero point ■ At 6 o'clock

→ Other scale ranges on request

Process connection	
Standard	<ul style="list-style-type: none"> ■ EN 837-1 ■ ISO 7 ■ ANSI/B1.20.1
Size	
EN 837-1	<ul style="list-style-type: none"> ■ G ¼ B, male thread ■ G ½ B, male thread ■ M14 x 1.5, male thread
ANSI/B1.20.1	<ul style="list-style-type: none"> ■ ¼ NPT, male thread ■ ½ NPT, male thread
ISO 7	<ul style="list-style-type: none"> ■ R ¼, male thread ■ R ½, male thread
Restrictor	<ul style="list-style-type: none"> ■ Without ■ Ø 0.6 mm [0.024"], stainless steel ■ Ø 0.3 mm [0.012"], stainless steel
Material (wetted)	
Process connection	<ul style="list-style-type: none"> ■ Stainless steel 1.4571 (316Ti) ■ Stainless steel 1.4404 (316L)
Bourdon tube	Stainless steel 1.4404 (316L)

→ Other process connections on request





Operating conditions	
Medium temperature	-40 ... +100 °C [-40 ... +212 °F]
Ambient temperature	-40 ... +60 °C [-40 ... +140 °F]
Pressure limitation	
Steady	3/4 x full scale value
Fluctuating	2/3 x full scale value
Short time	Full scale value
Ingress protection per IEC/EN 60529	<ul style="list-style-type: none"> ■ IP54 ■ IP65 ¹⁾

1) Only selectable for scale ranges from 0 ... 16 bar [0 ... 250 psi] and centre back mount

Approvals

Logo	Description	Region
	EU declaration of conformity Pressure equipment directive PS > 200 bar, module A, pressure accessory	European Union
-	CRN Safety (e.g. electr. safety, overpressure, ...) For scale ranges ≤ 1,000 bar	Canada

Optional approvals

Logo	Description	Region
 	EU declaration of conformity ATEX directive Hazardous areas - Ex h Gas II 2G Ex h IIC T6 ... T1 Gb X Dust II 2D Ex h IIC T85°C ... T100°C Db X	European Union
	PAC Kazakhstan Metrology, measurement technology	Kazakhstan
-	MChS Permission for commissioning	Kazakhstan
	PAC Ukraine Metrology, measurement technology	Ukraine
	PAC Uzbekistan Metrology, measurement technology	Uzbekistan
-	PAC China Metrology, measurement technology	China
-	KBA²⁾ Automotive Components for motor vehicles using natural gas (CNG/LNG) – UN no. R 110	International

1) Not available for NS 63 [2 1/2"]

2) Not available for all versions

Manufacturer's declaration

Logo	Description
-	Pressure equipment directive (PED) for maximum allowable pressure PS ≤ 200 bar
-	Suitability of wetted materials for drinking water in accordance with the European 4MS initiative

Certificates (option)

Certificates	
Certificates	<ul style="list-style-type: none"> ■ 2.2 test report per EN 10204 (e.g. state-of-the-art manufacturing, indication accuracy) ■ 3.1 inspection certificate per EN 10204 (e.g. indication accuracy)
Recommended calibration interval	1 year (dependent on conditions of use)

→ For approvals and certificates, see website

Dimensions in mm [in]

Model 131.11, lower mount (radial)

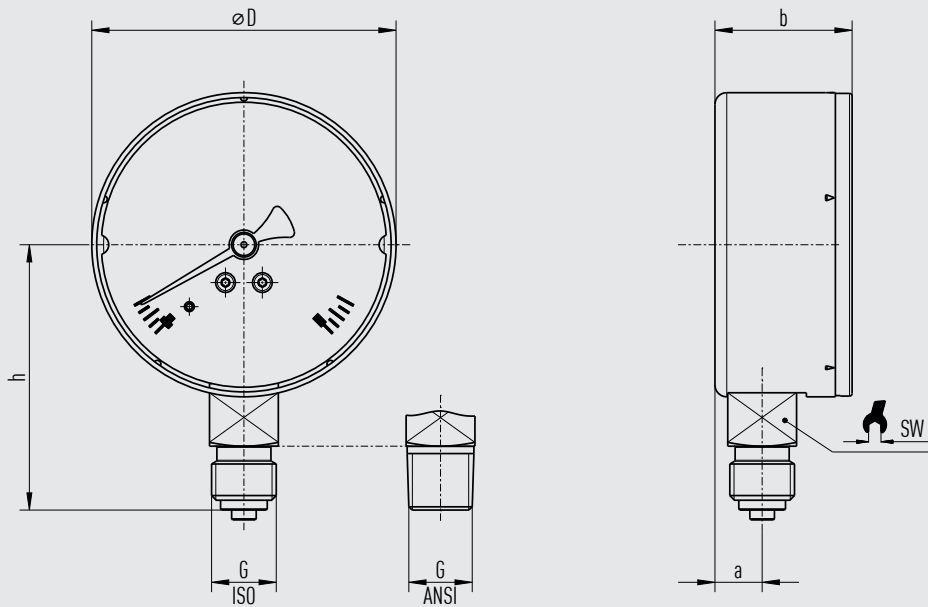

2184087.02

NS	G ¹⁾	Dimensions in mm [in]					Weight in kg [lb]
		D	h ±1 [0.04]	a	b ±1 [0.04]	SW	
40 [1.5"]	G ½ B, ½ NPT	39 [1.54]	36 [1.42]	9 [0.35]	25 [0.98]	14 [0.55]	0.05 [0.11]
	G ¼ B, ¼ NPT	39 [1.54]	39 [1.54]	9 [0.35]	25 [0.98]	14 [0.55]	0.05 [0.11]
50 [2"]	G ½ B, ½ NPT	49 [1.93]	44 [1.73]	9 [0.35]	29 [1.41]	14 [0.55]	0.09 [0.2]
	G ¼ B, ¼ NPT	49 [1.93]	47 [1.85]	9 [0.35]	29 [1.41]	14 [0.55]	0.09 [0.2]
63 [2 ½"]	G ½ B, ½ NPT	62 [2.44]	51 [2.01]	10 [0.39]	28 [1.1]	14 [0.55]	0.12 [0.26]
	G ¼ B, ¼ NPT	62 [2.44]	54 [2.13]	10 [0.39]	28 [1.1]	14 [0.55]	0.12 [0.26]

1) The G ½ B process connection of this instrument is manufactured without a centring spigot and with a thread runout instead of a thread undercut.

Model 131.11, centre back mount

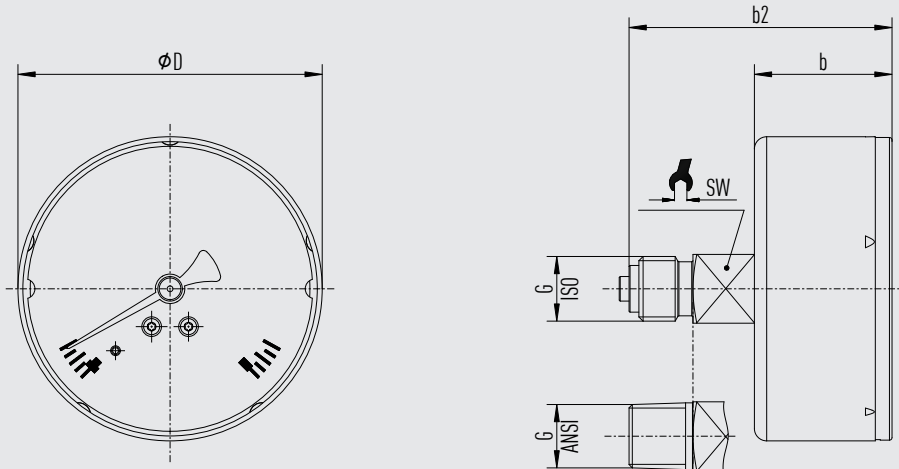

2184109.02

NS	G ¹⁾	Dimensions in mm [in]				Weight in kg [lb]
		D	b2	b ±1 [0.04]	SW	
40 [1.5"]	G 1/8 B, 1/8 NPT	39 [1.54]	52.5 [2.07]	27.5 [1.09]	14 [0.55]	0.05 [0.11]
	G 1/4 B, 1/4 NPT	39 [1.54]	52.5 [2.07]	27.5 [1.09]	14 [0.55]	0.05 [0.11]
50 [2"]	G 1/8 B, 1/8 NPT	49 [1.93]	53.5 [2.11]	29 [1.14]	14 [0.55]	0.09 [0.2]
	G 1/4 B, 1/4 NPT	49 [1.93]	53.5 [2.11]	29 [1.14]	14 [0.55]	0.09 [0.2]
63 [2 1/2"]	G 1/8 B, 1/8 NPT	62 [2.44]	53.5 [2.11]	28 [1.1]	14 [0.55]	0.12 [0.26]
	G 1/4 B, 1/4 NPT	62 [2.44]	53.5 [2.11]	28 [1.1]	14 [0.55]	0.12 [0.26]

1) The G 1/8 B process connection of this instrument is manufactured without a centring spigot and with a thread runout instead of a thread undercut.

Ordering information

Model / Nominal size / Connection location / Scale range /
Process connection / Options



© 02/2009 WIKA Alexander Wiegand SE & Co. KG, all rights reserved.
The specifications given in this document represent the state of engineering at the time of publishing.
We reserve the right to make modifications to the specifications and materials.
In case of a different interpretation of the translated and the English data sheet, the English wording shall prevail.



WIKAL Alexander Wiegand SE & Co. KG
Alexander-Wiegand-Straße 30
63911 Klingenberg/Germany
Tel. +49 9372 132-0
info@wika.de
www.wika.de