

# P70 & P70 NACE Regulators

- Superior regulation characteristics
- Rugged, corrosion-resistant construction
- Excellent stability and repeatability
- High flow capacity (80 SCFM)
- Self-relieving
- Standard tapped vent
- Soft relief seat for low gas consumption
- Several mounting options

The BelGAS P70 Regulators are reliable precision units designed for instrumentation and general purpose use.

Test data for these regulators show excellent performance characteristics compared with those of similar units presently on the market. These BelGAS regulators are generally superior in regulated pressure vs. flow, forward-to-reverse flow offset, supply pressure sensitivity, repeatability and stability.

Ruggedly designed and constructed, the regulators have housings of diecast aluminum. The P70 Regulator is finished with vinyl paint (which resists scratching, weathering & other physical abuse), while the P70 NACE is supplied with an epoxy paint for added corrosion protection. The P70 regulator is pressure and leak tested prior to shipment from the factory.

The full flow gauge ports are convenient for gauge installation and can also be used as an additional full flow outlet ports.

## Applications

The design of these regulators is especially well suited to pilot-operated level, pressure and flow controllers and pneumatic instruments.



## P70 & P70 NACE Specifications

Sensitivity	1/4" WC (6.4 mm)	
Flow Capacity	80 SCFM	2266 LPM
Effect of Supply Pressure variation (25 PSIG) on Outlet Pressure	< 0.05 PSIG	0.003 BAR
Exhaust Capacity (5 PSIG above 20 PSIG set point)	3 SCFM Typical	85 LPM
Maximum Input/Supply Pressure	250 PSIG	17.2 BAR
Effect of Changes in Flow on Regulated Pressure (100 PSIG/6.9 BAR Supply)	2.5 PSIG (0.2 BAR) over flow 50 SCFM (1416 LPM)	
Output Pressure Ranges	0-15 PSIG 0-30 PSIG 1-60 PSIG 2-100 PSIG 2-150 PSIG	0-1.0 BAR 0-2.1 BAR 0.1-4.1 BAR 0.2-6.9 BAR 0.2-10.3 BAR
Temperature Range	-40 to 200 °F	-40 to 93 °C
Total Air Consumption @ Maximum Output	0.1 SCFH	0.05 LPM
Port Size	1/4 NPT, 3/8 NPT, 1/2 NPT	
Size	3.0" x 3.0" x 6.0"	76 x 76 x 152 mm
Weight	1.41 lb.	0.6 kg
Mounting	Pipe, Panel or Bracket	

## P70 & P70 NACE Part Matrix

<b>P070</b>								<b>0 0 0</b>	Port Size
	▲	▲	▲	▲	▲	▲	▲	▲	1/4 NPT
	<b>02</b>								3/8 NPT
	<b>03</b>								1/2 NPT
	<b>04</b>								Spring Range
		<b>015</b>							0 - 15 PSIG 0 - 1.0 BAR
		<b>030</b>							0 - 30 PSIG 0 - 2.1 BAR
		<b>060</b>							1 - 60 PSIG 0.1 - 4.1 BAR
		<b>100</b>							2 - 100 PSIG 0.2 - 6.9 BAR
		<b>150</b>							2 - 150 PSIG 0.2 - 10.3 BAR
			<b>0</b>						Special Construction
			<b>1</b>						Standard
			<b>N</b>						Epoxy Paint
									NACE Construction (Wetted Parts)
				<b>1</b>					Adjusting Method
				<b>2</b>					Square Head Screw
									Knob (Handwheel)
									Relieving Options
				<b>0</b>					Relieving*
				<b>1</b>					Non-Relieving
					<b>0 0 0</b>				

\* Relieving version will have no constant bleed.

## Materials of Construction

Body	Die Cast Aluminum
Adjusting Screw	P70 - Zinc Plated Steel P70 NACE - 316 Stainless Steel
Trim	Plated Steel, Brass, Acetal Resin
Knob	Phenolic Plastic (option)
Spring:	Music Wire
Diaphragm Material	P70 - Buna-N Elastomer with Polyester Fabric P70 NACE - Fluorocarbon with Dacron Fabric

# P70 Flow Data

Outlet Pressure Range	Outlet Pressure Setting		Inlet Pressure		Air Capacity (SCFH)	
	PSIG	BAR	PSIG	BAR	20% Offset	MAX
0 to 15 PSIG (0 to 1 BAR)	5	0.3	10	0.7	140	570
			15	1.0	150	690
			25	1.7	185	960
			50	3.5	300	1500
			100	6.9	360	2700
	10	0.7	15	1.0	330	690
			25	1.7	492	930
			50	3.5	750	1560
			100	6.9	1260	2700
			125	8.6	1680	3300
	15	1.0	25	1.7	570	960
			50	3.5	900	1620
			100	6.9	1680	2820
			125	8.6	2100	3480
			15	1.0	110	840
0 to 30 PSIG (0 to 2.1 BAR)	5	0.3	50	3.5	250	1800
			100	6.9	345	3300
			125	8.6	400	3600
			25	1.7	450	1320
	15	1.0	50	3.5	1140	1920
			100	6.9	1800	3900
			125	8.6	2160	4500
			35	2.4	1320	1740
	25	1.7	50	3.5	1800	2280
			100	6.9	2820	3900
			125	8.6	3300	4800
	30	2.1	40	2.8	1500	1800
			50	3.5	1560	2100
			100	6.9	3240	3900
	1 to 60 PSIG (0.07 to 4.1 BAR)	20	1.4	30	2.1	600
50				3.5	960	1620
100				6.9	1680	2820
125				8.6	2280	3480
30		2.1	40	2.8	870	1440
			50	3.5	1110	1620
			100	6.9	1980	3060
			125	8.6	2700	3780
40		2.8	50	3.5	1050	1800
			100	6.9	2100	3300
			125	8.6	2700	4080
60		4.2	70	4.8	1560	2700
			100	6.9	2400	3720
			125	8.6	3000	4500
2 to 100 PSIG (0.14 to 6.9 BAR)		40	2.8	50	3.5	1260
	100			6.9	2280	3960
	125			8.6	2820	4800
	60	4.2	70	4.8	1800	3000
			100	6.9	2700	4050
			125	8.6	3360	4920
	80	5.5	100	6.9	3000	4140
			125	8.6	3900	5040
			110	7.6	3300	4500
100	6.9	125	8.6	4020	5100	
		60	4.1	870	2700	
		100	6.9	1440	3720	
2 to 150 PSIG (0.14 to 10.3 BAR)	50	3.5	125	8.6	1620	5220
			85	5.9	1800	3780
			100	6.9	2250	4380
	75	5.2	125	8.6	2760	5280
			110	7.6	3060	4800
	100	6.9	125	8.6	3660	5280

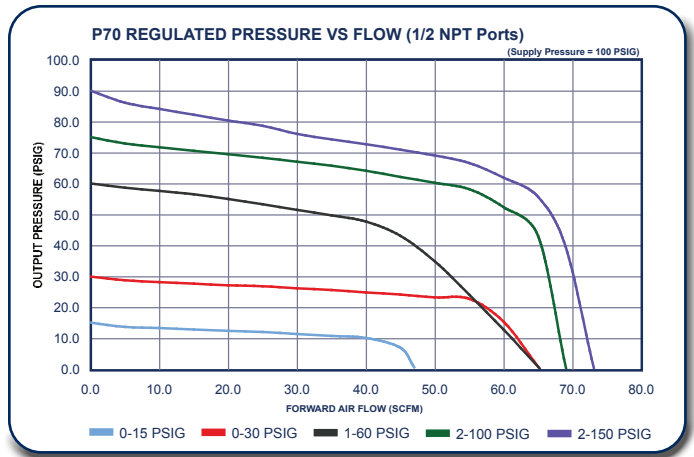

# P70 Dimensions

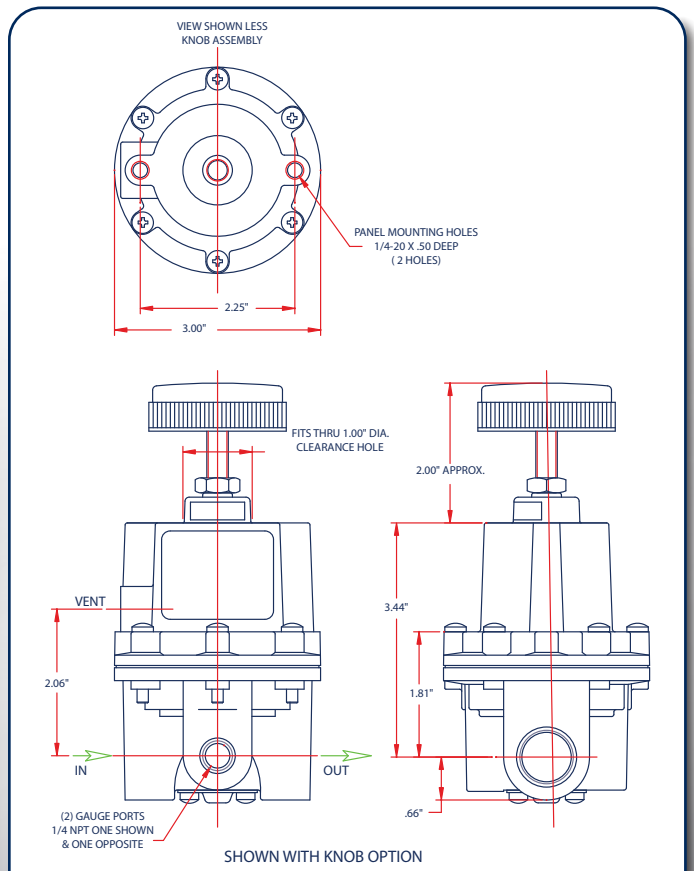

## Optional Mounting Bracket

Part Number 607-000-047

