

P289RC Exhaust Booster

The P289RC is designed as a high capacity exhaust booster and used in applications utilizing large pneumatic actuators and valve controls where a rapid response is required. Ideally suited in applications with surge valves or recycle valves on compressor stations where the operation is sped up to accommodate compressor surges and sudden pressure changes from the out devices.

The 1/4" spring case port is connected to the controlling instrument such as an I/P, Controller or Positioner, and the 1" supply/relief port is connected to the actuator. It is required for proper operation that a bypass valve connect the inlet and outlet of the P289RC wherever is convenient.

The greater the differential pressure develops across the bypass valve the further the exhaust booster opens. The factory set opening of the P289RC is approximately 1.5 PSIG and is not adjustable in the field. As the differential pressure decreases between the controlling instrument and the actuator, the booster exhaust valve closes.



Materials of Construction

	P289RC 1" & 3/4" x 1"
Body, Bonnet	Aluminum
Diaphragm	Nitrile or Fluoroelastomer
Gaskets	Composite
O-rings	Nitrile or Fluoroelastomer
O-ring Piston and Spacer	Aluminum
Stem	Aluminum
Spring	Zinc-plated steel
Diaphragm Piston	Zinc-plated steel

Specifications

	P289RC 1" & 3/4" x 1"	
Port Size	1 NPT	
Maximum Relief Inlet Pressure	150 PSIG	8.6 BAR
Temperature Range	-20–150 °F with Nitrile and Neoprene	
	0–300 °F with Fluoroelastomer	
Approximate Weight	3 lbs.	1.36 kg
Exhaust Max Rate	C _v =22	107,988 scfh

P289RC 1" Part Matrix

P289RC			000000	
	↑	↑	↑	Body Size
	07			3/4" x 1" NPT
	08			1" NPT
				Diaphragm Material
		0		Nitrile
		1		Fluoroelastomer

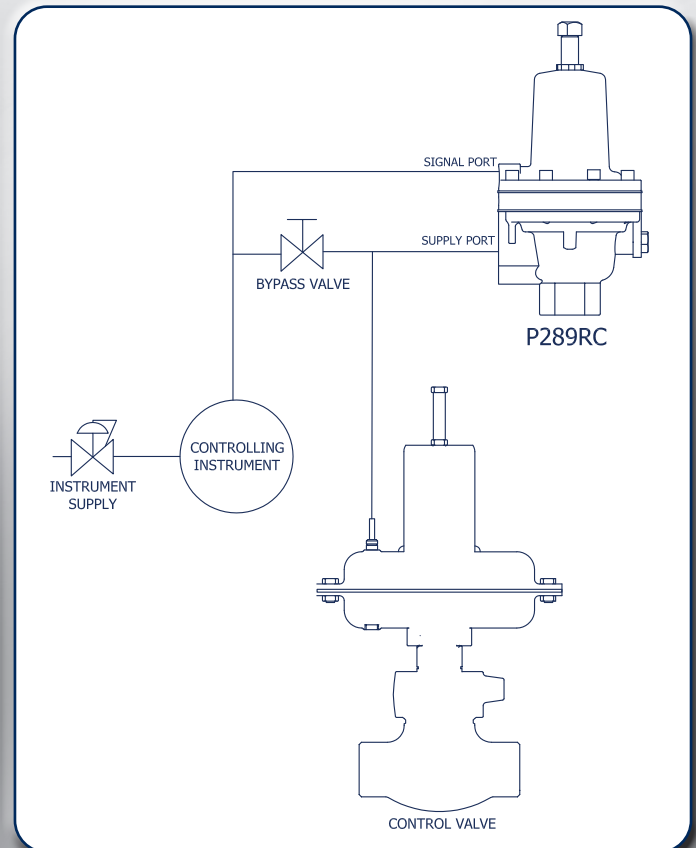

P289RC 1" Parts

Item	Description	Qty.	Part Number
1	Body, Aluminum	1" NPT	664-295-000
		3/4" x 1" NPT	664-386-000
2	Stem, Aluminum	1	689-022-000
3	O-ring	Nitrile	649-000-003
		Fluorocarbon	649-000-343
4	O-ring	Nitrile	649-293-000
		Fluorocarbon	649-293-001
5	O-Ring Piston, Aluminum	1	637-311-000
6	Spacer Tube, Stainless Steel	2	654-194-000
7	Pipe Plug, Plated Steel	1	639-099-000
8	Stem Guide Assembly	1	814-019-000
9	Diaphragm	Nitrile	600-497-000
		Fluorocarbon	600-497-001
10	Spacer Ring, Aluminum	1	654-195-000
11	Large Piston, Plated Steel	1	637-306-000
12	Machine Screw	7	648-466-010
13	Small Piston, Plated Steel	2	637-319-000
14	Lower Spring Retainer, Zinc Plated Steel	1	643-191-000
15	Hex Nut, Plated Steel	1	634-162-000
16	Spring, Stainless Steel	1	655-790-000
17	Screw Seal, Nitrile	1	662-245-000
18	Hex Nut, Plated Steel	1	634-154-000
19	Adjusting Screw, Plated Steel	1	648-585-000
20	Spring Guide, Plated Steel	1	626-079-000
21	Bonnet, Aluminum	1	604-237-000
22	Gasket, Composite	3	624-062-000
23	Spacer, Stainless Steel	1	654-196-000
24	Screen, Stainless Steel	1	647-029-000
25	Washer, Steel	1	662-204-000
26	Machine Screw, Stainless Steel	2	648-488-000
27	O-Ring Spacer, Aluminum	1	654-177-000
28	Gasket, Neoprene	1	624-063-000
29	Screen, Stainless Steel	1	647-018-000
30	Retaining Ring, Plated Steel	1	664-051-000
31	Adjustment ScREW	1	648-584-000
	Diaphragm Assembly	FKM	804-295-000
		Nitrile	804-295-001
	Rebuild Kit	FKM	971-289-010
		Nitrile	971-289-011

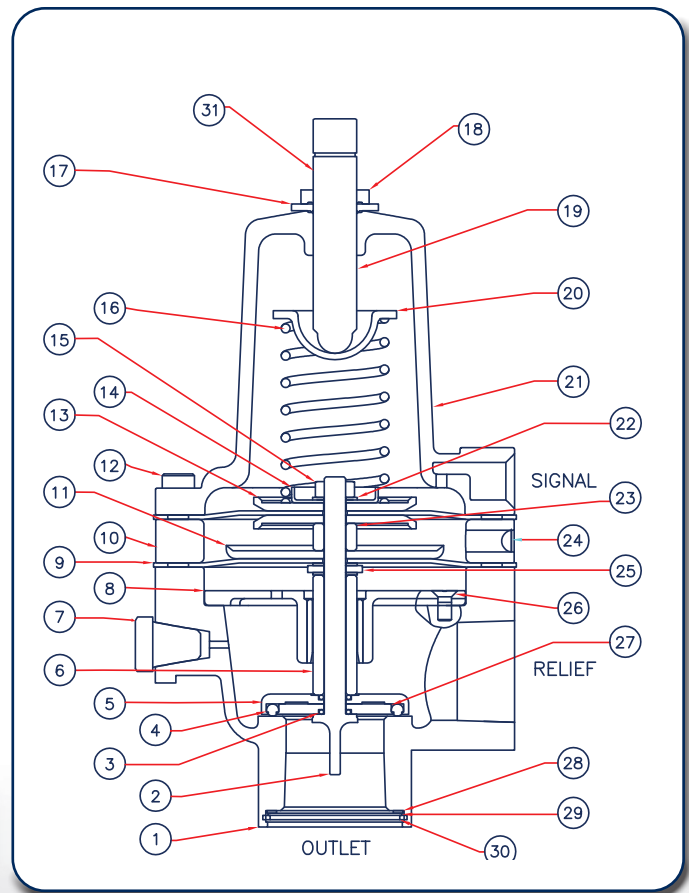

P289RC 1" Dimensions

