

P300 Pressure Regulator

- Minimize Sudden Downstream Load Change
- Wide Pressure Ranges
- P302 has internal relief valve for overpressure protection

The P300 series pressure regulator is a manual, direct acting, self-operating, spring loaded, adjustable regulator. The P300 series is used in applications where pressure reduction is required. The regulator will reduce the risk of “shock” from abrupt changes of downstream conditions. This can help prevent safety equipment from shutting an operation down.

Applications

- Compressors
- Gas Engines
- Service Regulators

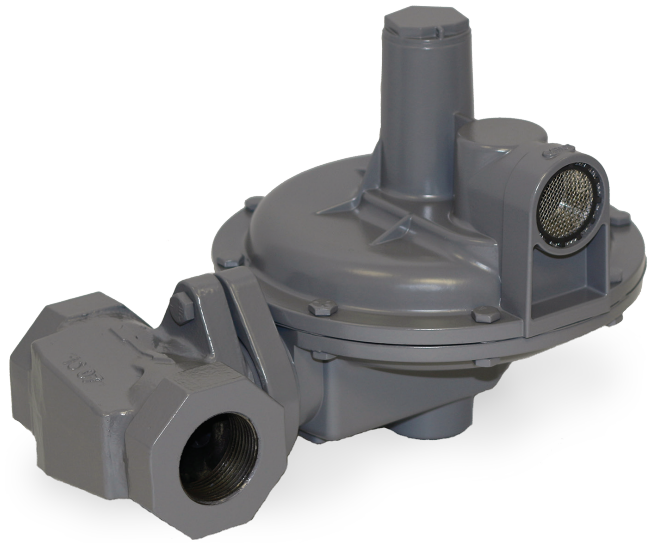

Materials of Construction

Adjusting Screw	Aluminum
Body	Ductile Cast Iron or WCB Steel
Bonnet	Aluminum
Closing Cap	Zinc
Diaphragm	Nitrile
Lower Casing	Aluminum
Molded Seat Assembly	Nitrile
Orifice	Aluminum
Flange	Ductile Iron / WCB Steel

P300 Series Maximum Inlet Pressure

Orifice Inches	Range	P301/P302		P310H/P302H	
		Maximum Inlet Pressure		Maximum Inlet Pressure	
		PSIG	BAR	PSIG	BAR
3/16"	Any	125	8.618	125	8.618
1/4"	Any	60	4.136	125	8.618
3/8"	Any	30	2.068	80	5.515
1/2"	Any	25	1.723	60	4.136
3/4"	Any	15	1.034	40	2.757

Specifications

Maximum Inlet	See Table 1	
Maximum Emergency Outlet	15 PSIG	
Pressure Ranges	See Table 2	
Port Sizes	1.25 NPT	
	1.5 NPT	
	1.5 NPT x 2 NPT	
	2 NPT	
Orifice Sizes	3/16"	
	1/4"	
	3/8"	
	1/2"	
	3/4"	
End Connections	NPT	
	150 RF Flange	Steel Units Only
	125 FF Flange	Iron Units Only
Temperature Range	-20°F to 180°F	
	-29°C to 82°C	
Approx. Weight	26 lbs. (11.8 kg)	

P300 Series Range Springs

Table 2				
Model	Spring Ranges		Spring Color	Part Number
	WC.	mBar		
P301 & P302	3 - 6 WC	9 - 15	Red	655-788-000
	5 - 8.5 WC	12 - 21	Silver	655-788-001
	6 - 14 WC	15 - 35	Blue	655-788-002
	12 - 28 WC	30 - 70	Green	655-788-003
	PSIG	Bar		
P301H & P302H	1 - 2 PSIG	.07 - .14	Black	655-788-004
	1.5 - 3 PSIG	.10 - .21	Olive	655-788-005
	2.5 - 5.5 PSIG	.17 - .38	Yellow	655-788-006
P301H Only	4.5 - 8 PSIG	.31 - .55	Brown	655-788-007

P300 Part Matrix

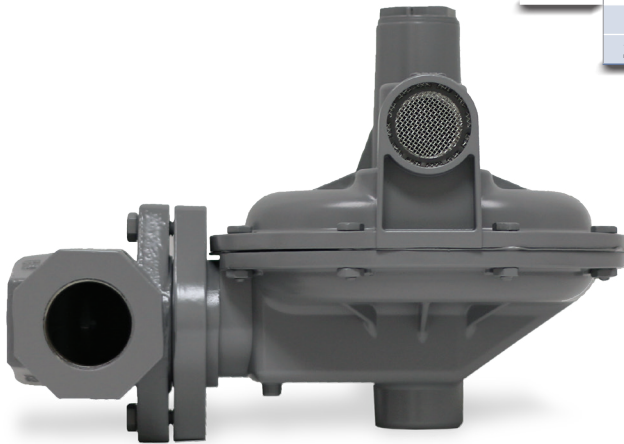

P300	↑	↑↑	↑↑↑	↑↑↑↑	↑	↑	↑	↑	↑	Version
1										Non-Relieving
2										Relieving
										Configuration
										Normal
										High
										Port Size
										1.25 NPT
										1.5 NPT
										1.5 x 2 NPT
										2 NPT
										Spring Range
										WC mBAR
										006 3 - 6" WC 9 - 15
										085 5 - 8.5" WC 12 - 21
										014 6 - 14" WC 15 - 35
										028 12 - 28" WC 30 - 70
										H Configura- tion
										PSIG BAR
										002 1 - 2 PSIG .07 - .14
										003 1.5 - 3 PSIG .10 - .21
										005 2 - 5.5 PSIG .17 - .38
										008 4.5 - 8 PSIG .31 - .55 301H Only
										Special Construction
										0 None
										A 150 RF (2" Steel Only)
										E 125 FF (2" Iron Only)
										Orifice
										3 3/16"
										4 1/4"
										6 3/8"
										8 1/2"
										B 3/4"
										Port Orientation
										1 Up
										2 Down
										3 Right (Standard)
										4 Left
										Bonnet Orientation
										C 12 O'clock
										D 3 O'clock
										E 6 O'clock
										F 9 O'clock (Standard)
										Body Material
										0 Iron
										2 Steel (2" Only)

P300 Regulator Rebuild Kits

	Kit Includes	Part Number
P300 Regulator	Diaphragm, Disk Holder, Cap Gasket, O-Ring	971-300-000

P300 Body Orientation*

* Port orientation is based on the body's "Out" port location in relation to the top view of the regulator.

P300 Vent Positions

P300 Dimensions

Body Size	A		A2			B	C	D			
	Inches	NPT	125 FF Flange	150 RF Flange	NPT	125 FF Flange	150 RF Flange	NPT	NPT	NPT	125 FF Flange
1.25	4.50				2.31			6.07	9.92	1.51	
1.5	4.50				2.31			6.07	9.92	1.51	
1.5 x 2	6.13				2.87			6.66	10.05	2.15	
2	6.13	10	10		2.87	5.00	5.00	6.66	10.05	2.15	

P300 Head Only

P30							0
	↑	↑	↑↑↑	↑	↑	↑	Version
1							Non-Relieving
2							Relieving
							Configuration
0							Normal
H							High
							Spring Range
							WC mBAR
006							3 - 6" WC 9 - 15
085							5 - 8.5" WC 12 - 21
014							6 - 14" WC 15 - 35
028							12 - 28" WC 30 - 70
							H Version
							PSIG BAR
002							1 - 2 PSIG .07 - .14
003							1.5 - 3 PSIG .10 - .21
005							2.5 - 5.5 PSIG .17 - .38
008							4.5 - 8 PSIG .31 - .55 301H Only
							Special Construction
0							None
2							2" with Adapter for 2" BelGAS Body
							Bonnet Orientation
C							12 O'clock
D							3 O'clock (Standard)
E							6 O'clock
F							9 O'clock

P300 Standard

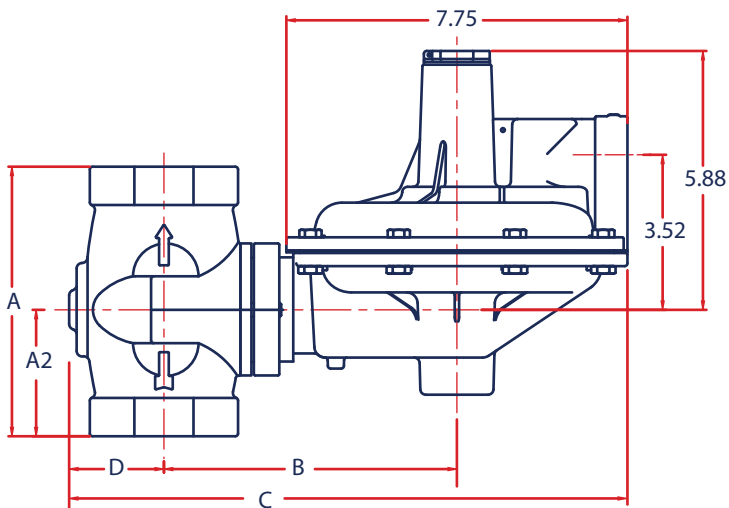

P300 Flanged

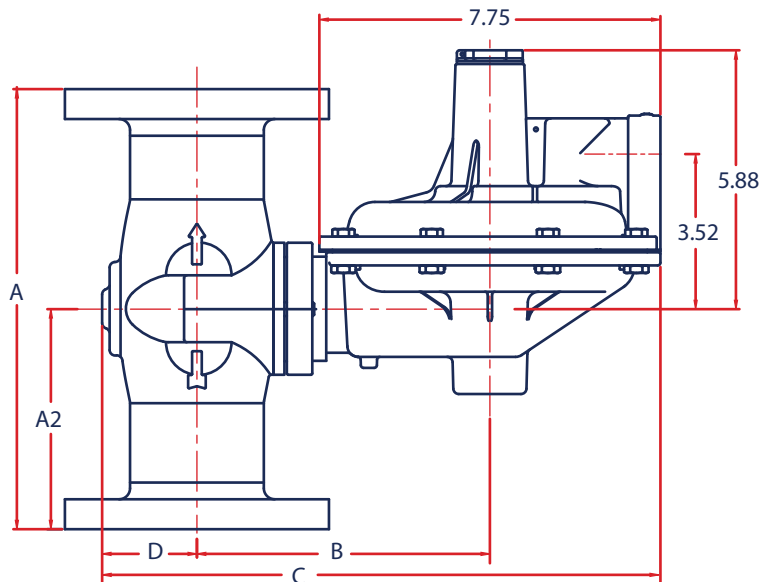

P302 Normal (0) Relief Capacities

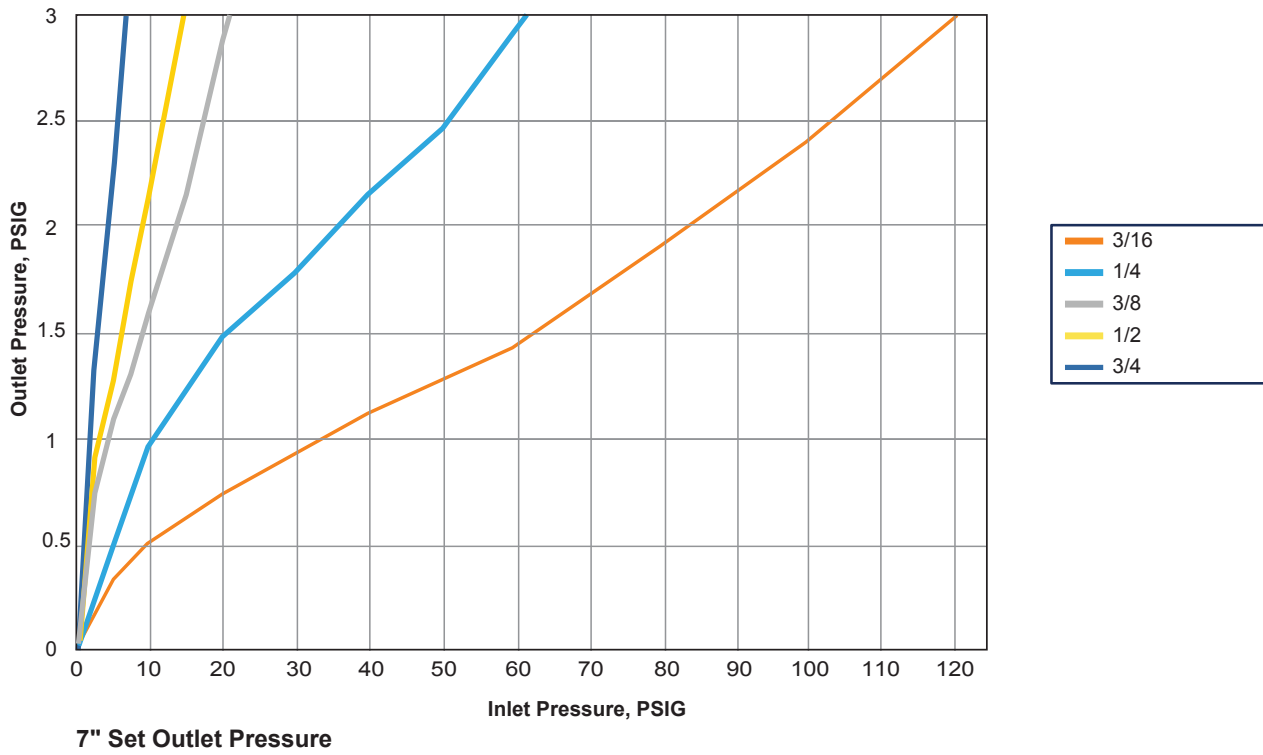

P302 H Relief Capacities

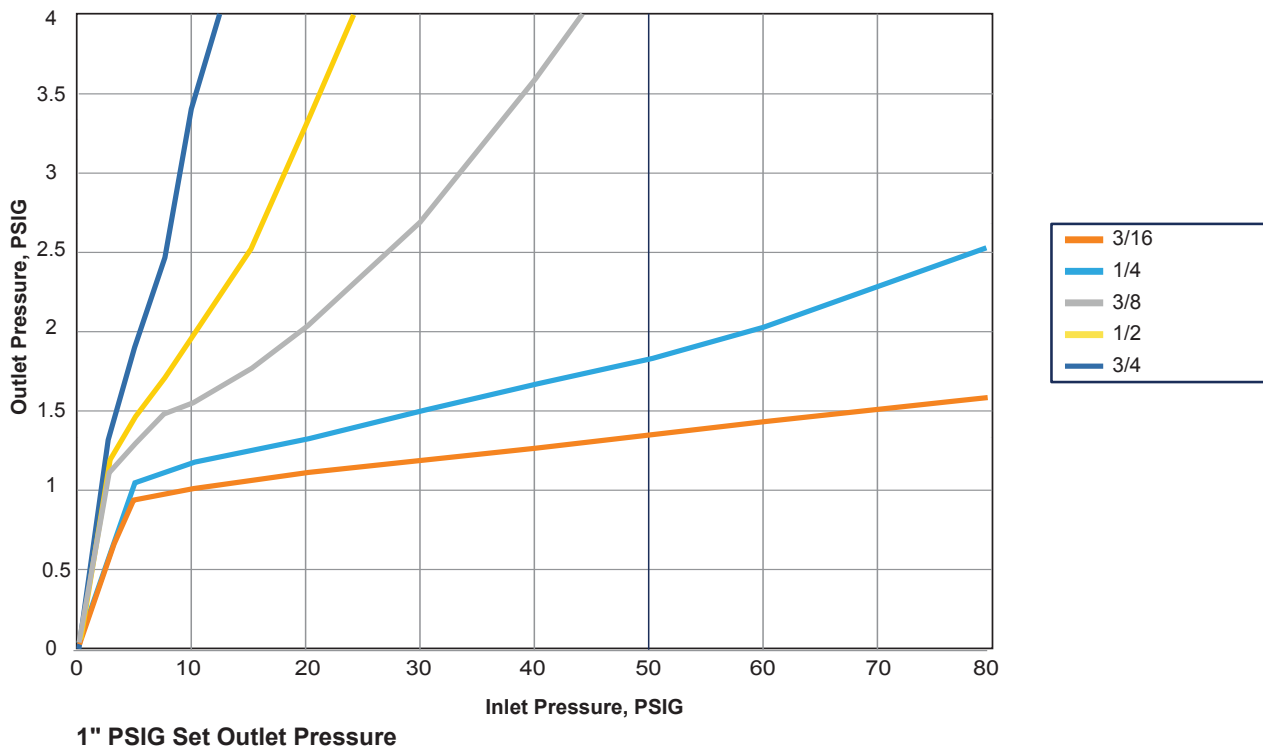

P301 & 302 Flow Capacities in SCFH (Nm³/h) of 0.6 Specific Gravity Natural Gas

Outlet Pressure, Spring Part Number, and Accuracy	Inlet Pressure		NPT 1-1/4 (DN32) Body Size				
			Orifice Size, Inches (mm)				
	PSIG	BAR	3/16 (4.8)	1/4 (6.4)	3/8 (9.5)	1/2 (13)	3/4 (19)
5 inches WC (12 mBAR) 655-788-000 1 inch WC (2.5 mBAR) droop	2	0.14			700 (18.8)	1000 (26.8)	1600 (42.9)
	5	0.34		700 (18.8)	1400 (37.5)	1900 (50.9)	2600 (70)
	10	0.69		1200 (32.2)	2300 (61.6)	3000 (80.4)	3500 (93.8)
	15	1.00	1050 (28.1)	1580 (42.30)	3000 (80.4)	3500 (93.8)	3500 (93.8)
	25	1.70	1400 (37.5)	2400 (64.3)	3500 (93.8)	3500 (93.8)	
	30	2.10	1550 (41.5)	2700 (72.4)	3500 (93.8)		
	60	4.10	2300 (61.6)	3500 (93.8)			
	80	5.17	3000 (80.4)				
	100	6.90	3200 (85.8)				
	125	8.60	3500 (93.8)				
7 inches WC (17 mBAR) 655-788-001 1 inch WC (2 mBAR) droop 2 inches WC (5 mBAR) boost	2	0.14					1400 (37.5)
	5	0.34			1100 (29.5)	1700 (45.6)	2000 (53.6)
	10	0.69		750 (20.1)	2100 (56.3)	2400 (64.3)	3500 (93.8)
	15	1.00	1000 (26.8)	1050 (28.1)	3000 (80.4)	3500 (93.8)	3500 (93.8)
	25	1.70	1250 (33.5)	1950 (52.3)	3000 (80.4)	3500 (93.8)	
	30	2.10	1500 (40.2)	2550 (68.3)	3500 (93.8)		
	60	4.10	2500 (67.0)	3500 (93.8)			
	80	5.17	2700 (72.4)				
	100	6.90	3500 (93.8)				
	125	8.60	3500 (93.8)				
11 inches WC (27 mBAR) 655-788-002 ± 2 inches WC (5 mBAR)	2	0.14			500 (13.4)	700 (18.8)	1200 (32.2)
	5	0.34			1100 (29.5)	1500 (40.2)	2100 (56.3)
	10	0.69			1750 (46.9)	2500 (67.0)	3500 (93.8)
	15	1.00		1200 (32.2)	2500 (67.0)	3400 (91.1)	3500 (93.8)
	25	1.70		1900 (50.9)	3500 (93.8)	3500 (93.8)	
	30	2.10	1500 (40.2)	2100 (56.3)	3500 (93.8)		
	40	2.80	1900 (50.9)	3200 (85.8)			
	60	4.10	2300 (61.6)	2620 (70.2)			
	80	5.17	2750 (73.7)				
	100	6.90	3400 (91.1)				
125	8.60	3500 (93.8)					
20 inches WC (50 mBAR) 655-788-003 ± 3 inches WC (7 mBAR)	5	0.34				1000 (26.8)	1600 (42.9)
	10	0.69			1150 (30.8)	1850 (49.6)	2600 (69.7)
	15	1.00			1650 (44.2)	2700 (72.4)	3400 (91.1)
	25	1.70		1150 (30.8)	2700 (72.4)	3500 (93.8)	
	30	2.10	1200 (32.2)	1400 (37.5)	3200 (85.8)		
	40	2.80	1350 (36.2)	2000 (53.6)			
	60	4.10	1900 (50.9)	2900 (77.7)			
	80	5.17	2600 (69.7)				
	100	6.90	3000 (80.4)				
	125	8.60	3500 (93.8)				

1. Limited due to boost

 - Shaded areas show where indicated droop would be exceeded regardless of capacity.

 - Shaded areas show where maximum operating inlet pressure for a given port diameter is exceeded.

P301 & 302 Flow Capacities in SCFH (Nm³/h) of 0.6 Specific Gravity Natural Gas

Outlet Pressure, Spring Part Number, and Accuracy	Inlet Pressure		NPT 1-1/2 (DN40) & 2" (DN50) Body Size				
			Orifice Size, Inches (mm)				
	PSIG	BAR	3/16 (4.8)	1/4 (6.4)	3/8 (9.5)	1/2 (13)	3/4 (19)
5 inches WC (12 mBAR) 655-788-000 1 inch WC (2.5 mBAR) droop	2	0.14			750 (20.1)	1150 (30.8)	1700 (45.6)
	5	0.34		700 (18.8)	1550 (41.5)	2250 (60.3)	3500 (93.8)
	10	0.69		1400 (37.5)	2600 (69.7)	3500 (93.8)	3500 (93.8)
	15	1.00	1080 (28.9)	1850 (49.6)	3500 (93.8)	3500 (93.8)	3500 (93.8)
	25	1.70	1450 (38.9)	2450 (65.7)	2300 (61.6)	2600 (69.7)	
	30	2.10	1600 (42.9)	2750 (73.7)	1900 (50.9)		
	60	4.10	2600 (69.7)	3500 (93.8)			
	80	5.17	3300 (88.4)				
	100	6.90	3500 (93.8)				
	125	8.60	3500 (93.8)				
7 inches WC (17 mBAR) 655-788-001 1 inch WC (2 mBAR) droop 2 inches WC (5 mBAR) boost	2	0.14					1400 (37.5)
	5	0.34			1200 (26.8)	2000 (53.6)	3200 (85.8)
	10	0.69		1000 (26.8)	2400 (64.3)	3500 (93.8)	3500 (93.8)
	15	1.00	1050 (28.1)	1400 (37.5)	3300 (88.4)	3500 (93.8)	3500 (93.8)
	25	1.70	1400 (37.5)	2400 (64.3)	3500 (93.8)	2600 (69.7)	
	30	2.10	1600 (42.9)	1700 (72.4)	2400 (64.3)		
	60	4.10	2600 (69.7)	3500 (93.8)			
	80	5.17	3300 (88.4)				
	100	6.90	3500 (93.8)				
	125	8.60	3500 (93.8)				
11 inches WC (27 mBAR) 655-788-002 ± 2 inches WC (5 mBAR)	2	0.14			500 (13.4)	800 (21.4)	1250 (33.5)
	5	0.34			1150 (30.8)	1700 (45.6)	2500 (67.0)
	10	0.69			2000 (53.6)	3100 (83.1)	3500 (93.8)
	15	1.00		1250 (33.5)	3000 (80.4)	3500 (93.8)	3500 (93.8)
	25	1.70		195 (52.3)	3500 (93.8)	3500 (93.8)	
	30	2.10	1500 (40.2)	2300 (61.6)	3500 (93.8)		
	40	2.80	1900 (50.9)	3200 (85.8)			
	60	4.10	2650 (71.0)	3500 (93.8)			
	80	5.17	3250 (87.1)				
	100	6.90	3500 (93.8)				
125	8.60	3500 (93.8)					
20 inches WC (50 mBAR) 655-788-003 ± 3 inches WC (7 mBAR)	5	0.34				1050 (28.1)	1800 (48.2)
	10	0.69			1300 (34.8)	1900 (50.9)	3100 (83.1)
	15	1.00			1900 (50.9)	2850 (76.4)	3500 (93.8)
	25	1.70		1250 (33.5)	3100 (83.1)	3500 (93.8)	
	30	2.10	1300 (34.8)	1600 (42.9)	3500 (93.8)		
	40	2.80	1650 (44.2)	2200 (59.0)			
	60	4.10	2300 (61.6)	3300 (88.4)			
	80	5.17	2800 (75.0)				
	100	6.90	3200 (85.8)				
	125	8.60	3500 (93.8)				

1. Limited due to boost

- Shaded areas show where indicated droop would be exceeded regardless of capacity.
- Shaded areas show where maximum operating inlet pressure for a given port diameter is exceeded.

P301 & 302 Flow Capacities in SCFH (Nm³/h) of 0.6 Specific Gravity Natural Gas

Outlet Pressure, Spring Part Number, and Accuracy	Inlet Pressure		NPT 1-1/4 (DN32), 1-1/2 (DN40) & 2" (DN50) Body Sizes				
			Orifice Size, Inches (mm)				
	PSIG	BAR	3/16 (4.8)	1/4 (6.4)	3/8 (9.5)	1/2 (13)	3/4 (19)
1 PSIG Set (69 mBAR) 655-788-006 10% Droop	2	0.14	193 (5.2)	160 (4.3)	295 (7.9)	400 (10.7)	595 (15.9)
	5	0.34	300 (8.0)	381 (10.2)	440 (11.8)	748 (20.0)	1240 (33.2)
	10	0.69	450 (12.1)	465 (12.5)	690 (18.5)	1420 (38.1)	2200 (59.0)
	15	1.00	555 (14.9)	740 (19.8)	1290 (34.6)	2070 (55.5)	3350 (89.8)
	20	1.40	710 (19.0)	920 (24.7)	1880 (50.4)	2750 (73.7)	4500 (121.0)
	30	2.10	970 (26.0)	1160 (31.1)	3040 (81.5)	4180 (112.0)	5000 (134.0)
	40	2.80	1310 (35.1)	1620 (43.4)	4170 (112.0)	5000 (134.0)	5000 (134.0)
	60	4.10	1750 (46.9)	3300 (88.4)	5000 (134.0)	5000 (134.0)	
	80	5.17	2210 (59.2)	3400 (91.1)	5000 (134.0)		
	100	6.90	3100 (83.1)	3980 (107.0)			
	125	8.60	3760 (101.0)	3290 (88.2)			
3 PSIG Set (207 mBar) 655-788-007 10% Droop	4	0.28	303 (8.2)	207 (5.6)	478 (12.8)	548 (14.7)	1060 (28.4)
	5	0.34	374(10.0)	452 (12.1)	606 (16.2)	905 (24.3)	1290 (34.6)
	10	0.69	515 (13.8)	670 (18.0)	1130 (30.3)	1740 (46.6)	2450 (65.7)
	15	1.00	735 (19.7)	905 (24.3)	1680 (45.0)	2250 (60.3)	3230 (86.6)
	20	1.40	970 (26.0)	1030 (37.6)	2000 (53.6)	2770 (74.2)	4130 (111.0)
	30	2.10	1420 (38.1)	1755 (47.0)	2970 (79.6)	3870 (104.0)	5000 (134.0)
	40	2.80	1700 (45.6)	2200 (59.0)	4030 (108.0)	5000 (134.0)	5000 (134.0)
	60	4.10	2390 (64.1)	3070 (82.3)	5000 (134.0)	5000 (134.0)	
	80	5.17	3030 (81.2)	4000 (107.0)	5000 (134.0)		
	100	6.90	3550 (95.1)	4380 (117.0)			
	125	8.60	4180 (112.0)	4970 (133.0)			
5 PSI Set (345 mBar) 655-788-004 10% Droop	7	0.48					1480 (39.7)
	10	0.69	570 (15.3)	723 (19.4)	1030 (27.6)	1480 (39.7)	2040 (54.7)
	15	1.00	775 (20.8)	1030 (27.6)	1500 (40.2)	2130 (57.1)	3100 (83.1)
	20	1.40	980 (26.3)	1330 (35.6)	1940 (52.0)	2640 (70.8)	4080 (109.0)
	30	2.10	1390 (37.3)	1575 (42.2)	2710 (72.6)	3740 (100.0)	5000 (134.0)
	40	2.80	1740 (46.6)	2200 (59.0)	3480 (93.3)	4970 (133.0)	5000 (134.0)
	60	4.10	2380 (63.8)	3230 (86.6)	5000 (134.0)	5000 (134.0)	
	80	5.17	2970 (79.6)	4000 (107.0)	5000 (134.0)		
	100	6.90	3420 (91.7)	4830 (129.0)			
	100	6.90	389 (107.0)	5000 (134.0)			
6 PSI Set (414 mBar) 655-788-005 10% Droop	10	0.69	495 (13.3)	677 (18.1)	905 (24.3)	1360 (36.4)	1940 (52.0)
	15	1.00	735 (19.7)	981 (26.3)	1390 (37.3)	1940 (52.0)	2840 (76.1)
	20	1.40	970 (26.0)	1225 (32.8)	1740 (46.6)	2500 (67.0)	3550 (95.1)
	30	2.10	1355 (36.3)	1650 (44.2)	2520 (67.5)	3680 (98.6)	5000 (134.0)
	40	2.80	1650 (44.2)	2100 (56.3)	3820 (102.0)	4700/126.0)	5000 (134.0)
	60	4.10	2270 (60.8)	3100 (83.1)	5000 (134.0)	5000 (134.0)	
	80	5.17	3070 (82.3)	3870 (104.0)	5000 (134.0)		
	100	6.90	3420 (91.7)	4500 (121.0)			
	125	8.60	4000 (107.0)	5000 (134.0)			

1. Limited due to boost

- Shaded areas show where indicated droop would be exceeded regardless of capacity.
- Shaded areas show where maximum operating inlet pressure for a given port diameter is exceeded.

P301 & 302 Flow Capacities in SCFH (Nm³/h) of 0.6 Specific Gravity Natural Gas

Outlet Pressure, Spring Part Number, and Accuracy	Inlet Pressure		NPT 1-1/4 (DN32), 1-1/2 (DN40) & 2" (DN50) Body Sizes				
			Orifice Size, Inches (mm)				
	PSIG	BAR	3/16 (4.8)	1/4 (6.4)	3/8 (9.5)	1/2 (13)	3/4 (19)
1 PSIG Set (69 mBAR) 655-788-006 20% Droop	2	0.14	265 (7.1)	180 (4.8)	505 (13.5)	683 (18.3)	1060 (28.4)
	5	0.34	465 (12.5)	425 (11.4)	980 (26.3)	1390 (37.3)	2070 (55.5)
	10	0.69	730 (19.6)	905 (24.3)	1580 (42.3)	2270 (60.8)	3360 (90.0)
	15	1.00	1030 (27.6)	1360 (36.4)	2270 (60.8)	3160 (84.7)	4500 (121.0)
	20	1.40	1230 (86.6)	1660 (44.5)	3030 (81.2)	4000 (107.0)	5000 (134.0)
	30	2.10	1570 (42.1)	2320 (62.2)	4320 (116.0)	5000 (134.0)	5000 (134.0)
	40	2.80	1940 (52.0)	2940 (78.8)	5000 (134.0)	5000 (134.0)	5000 (134.0)
	60	4.10	2650 (71.0)	4180 (112.0)	5000 (134.0)	5000 (134.0)	
	80	5.17	3230 (86.6)	4440 (119.0)	5000 (134.0)		
	100	6.90	3910 (105.0)	5000 (134.0)			
	125	8.60	4440 (119.0)	5000 (134.0)			
3 PSIG Set (207 mBar) 655-788-007 20% Droop	4	0.28	394 (10.6)	490 (13.1)	955 (25.6)	1290 (34.6)	1940 (52.0)
	5	0.34	485 (13.0)	645 (17.3)	1160 (31.1)	1610 (43.1)	2400 (64.3)
	10	0.69	825 (22.1)	1320 (35.4)	2040 (54.7)	2940 (78.8)	4260 (114.0)
	15	1.00	1060 (28.4)	1740 (46.6)	2640 (76.1)	3800 (102.0)	5000 (134.0)
	20	1.40	1250 (33.5)	2070 (55.5)	3430 (91.9)	4640 (124.0)	5000 (134.0)
	30	2.10	1570 (42.1)	2710 (72.6)	4780 (128.0)	5000 (134.0)	5000 (134.0)
	40	2.80	1940 (52.0)	3290 (88.2)	5000 (134.0)	5000 (134.0)	5000 (134.0)
	60	4.10	2630 (70.5)	4490 (120.0)	5000 (134.0)	5000 (134.0)	5000 (134.0)
	80	5.17	3290 (88.2)	5000 (134.0)	5000 (134.0)		
	100	6.90	4000 (107.0)	5000 (134.0)			
	125	8.60	4830 (129.0)	5000 (134.0)			
5 PSI Set (345 mBar) 655-788-004 20% Droop	7	0.48					2710 (72.6)
	10	0.69	750 (20.1)	1120 (30.0)	1830 (49.0)	2580 (69.1)	3740 (100.0)
	15	1.00	1040 (27.9)	1610 (43.1)	2580 (69.1)	3680 (98.6)	5000 (134.0)
	20	1.40	1260 (33.8)	2000 (53.6)	3300 (88.4)	4640 (124.0)	5000 (134.0)
	30	2.10	1640 (44.0)	2630 (70.5)	4580 (123.0)	5000 (134.0)	5000 (134.0)
	40	2.80	1910 (51.2)	3290 (88.2)	5000 (134.0)	5000 (134.0)	5000 (134.0)
	60	4.10	2610 (69.9)	4450 (119.0)	5000 (134.0)	5000 (134.0)	
	80	5.17	3250 (87.1)	5000 (134.0)	5000 (134.0)		
	100	6.90	3900 (105.0)	5000 (134.0)			
	125	8.60	4670 (125.0)	5000 (134.0)			
	6 PSI Set (414 mBar) 655-788-005 20% Droop	10	0.69	710 (19.0)	1030 (27.6)	1680 (45.1)	2400 (64.3)
15		1.00	1030 (27.6)	1550 (41.5)	2520 (67.5)	3460 (92.7)	5000 (134.0)
20		1.40	1220 (32.7)	1940 (52.0)	3120 (83.6)	4330 (116.0)	5000 (134.0)
30		2.10	1650 (44.2)	2580 (69.1)	4420 (118.0)	5000 (134.0)	5000 (134.0)
40		2.80	1910 (51.2)	3230 (86.6)	5000 (134.0)	5000 (134.0)	5000 (134.0)
60		4.10	2610 (69.9)	4380 (117.0)	5000 (134.0)	5000 (134.0)	
80		5.17	3260 (87.9)	5000 (134.0)	5000 (134.0)		
100		6.90	3940 (106.0)	5000 (134.0)			
125		8.60	4670 (125.0)	5000 (134.0)			

1. Limited due to boost

- Shaded areas show where indicated droop would be exceeded regardless of capacity.
- Shaded areas show where maximum operating inlet pressure for a given port diameter is exceeded.

Interchangeability between the BelGAS P200 series and the P300 series

The unique feature about the BelGAS P300 regulator is that it utilizes the BelGAS P200 series 1.5" x 2" and the 2" x 2" body using a simple adaptor ring. The simplicity of down-sizing a system when a BelGAS P200 unit is installed is as easy as removing

the 2 body-to-head bolts and installing a BelGAS P300 head with the appropriate adaptor and bolts. Or, if a 1.5" x 2" or 2" x 2" BelGAS P300 is installed, the BelGAS P300 head can be removed and a BelGAS P200 head installed to up-size your system.

It is important to know, a P300 head can be mounted to a P200 2" body with the appropriate adaptor and bolts. A P200 head cannot be mounted to any existing P300 body unless confirmed to be a BelGAS 2" P200/P300 body.

Remove the BelGAS 2" P300 head

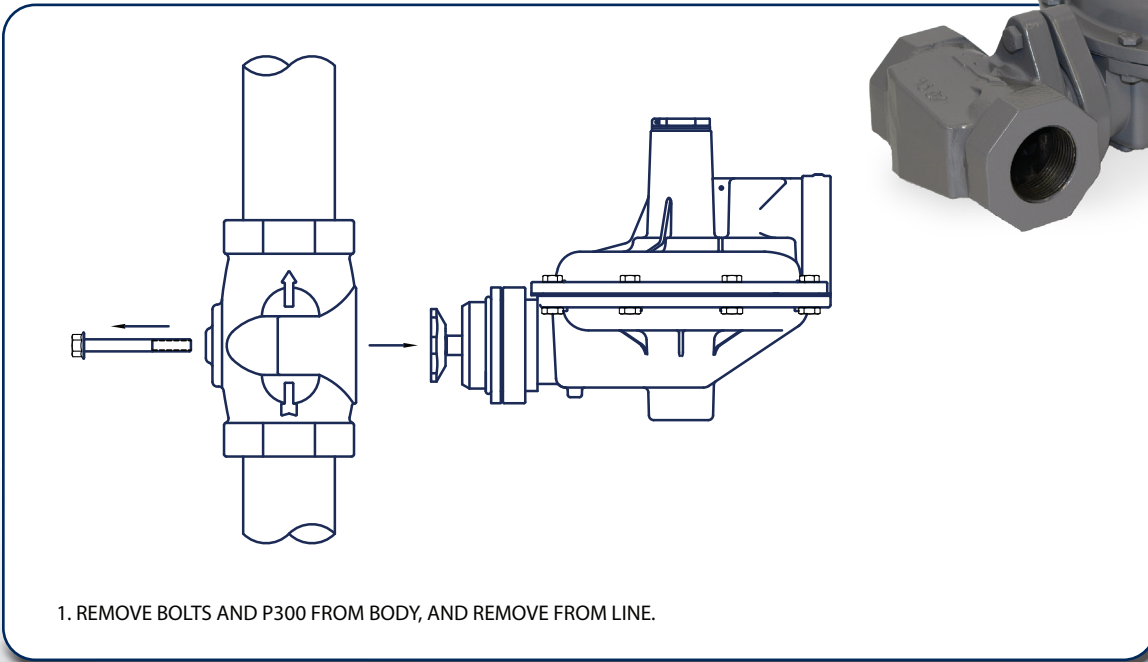

Install the BelGAS P200 head

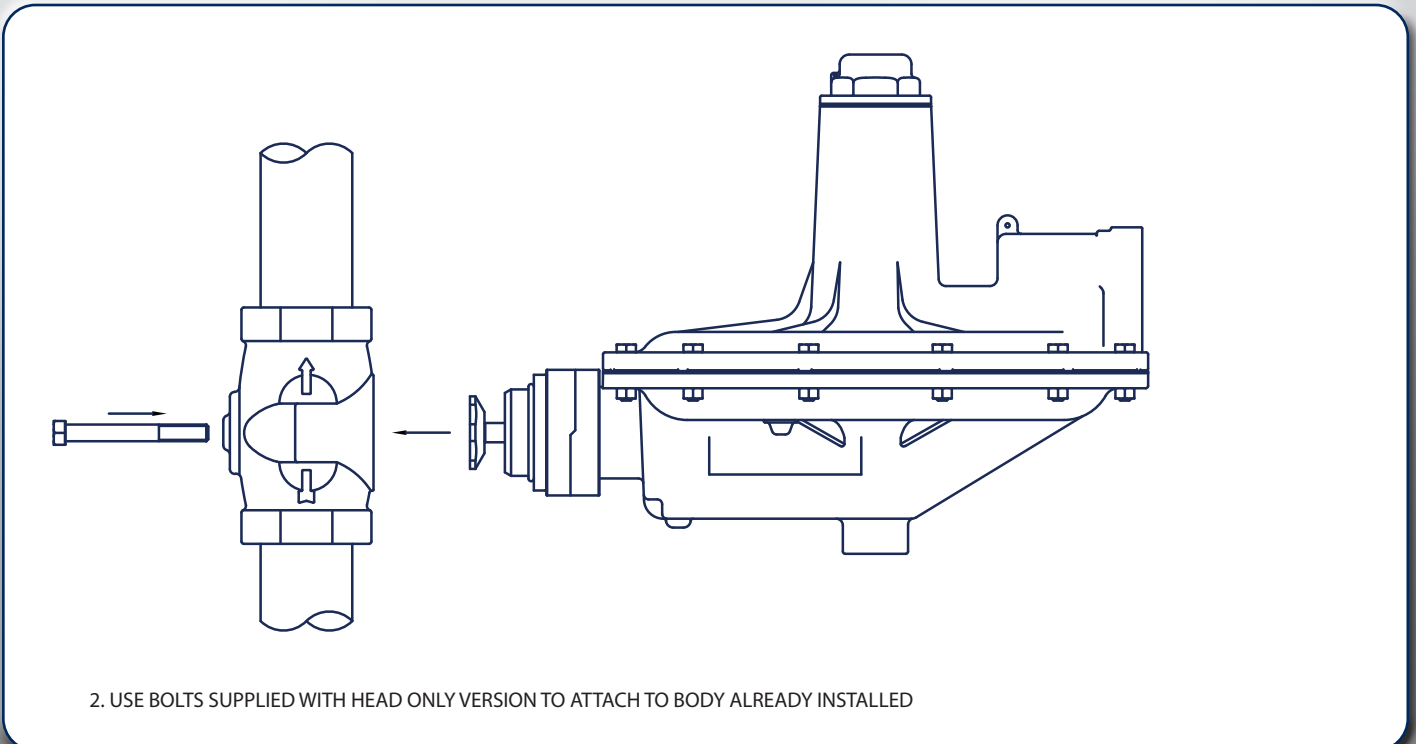

P300 Parts Drawing

P300

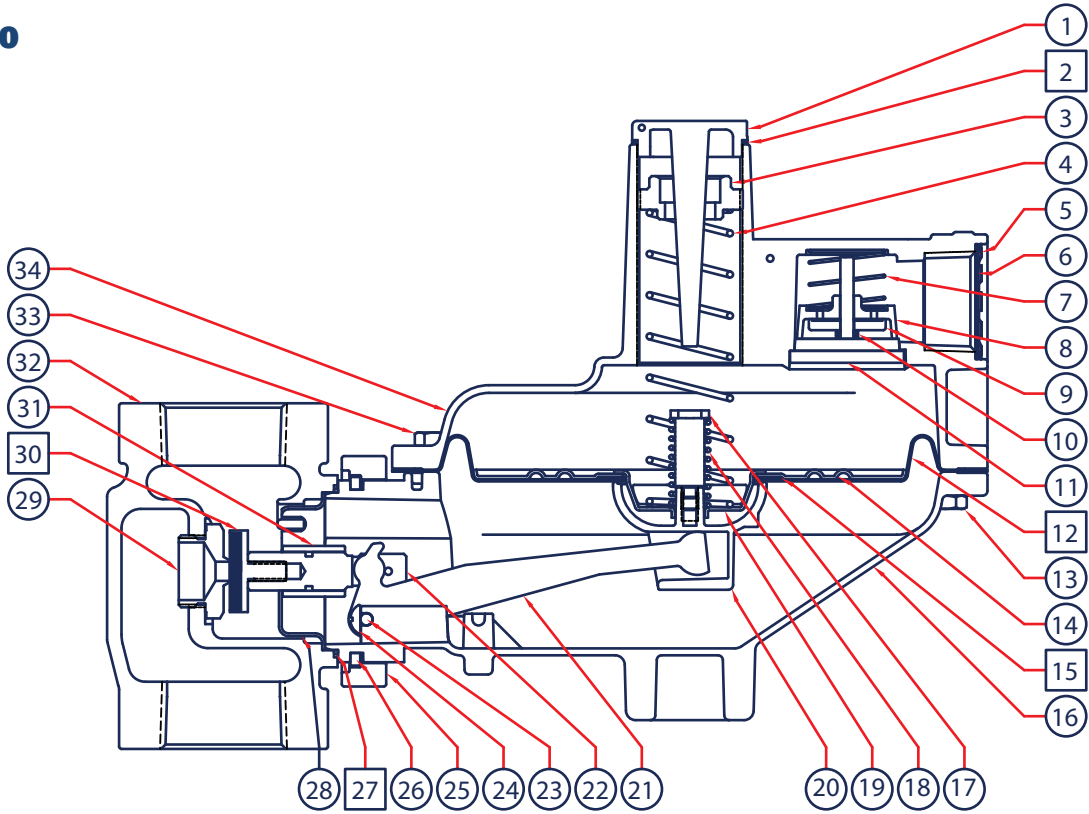

Parts included in Repair Kit 971-300-000

P300 H

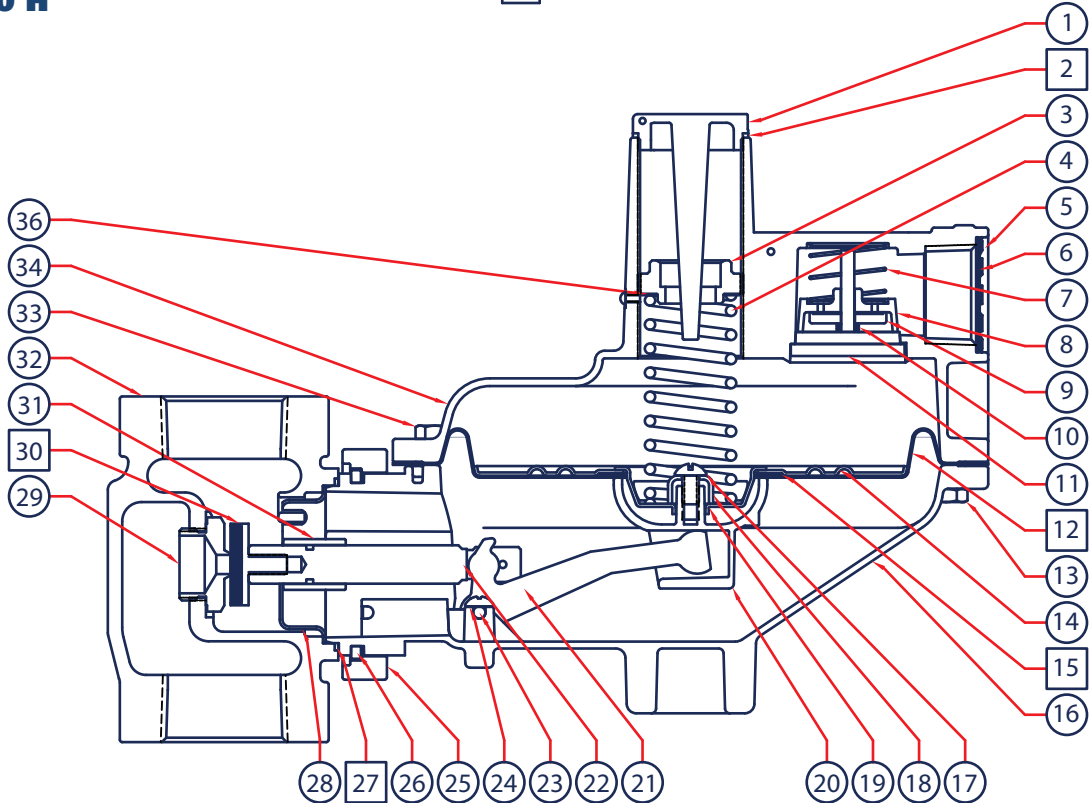

Parts included in Repair Kit 971-300-000

P300 Parts List

Item	Description	Qty.	Part Number
1	Bonnet Cap - Aluminum	1	610-096-000
2	Cap Gasket - Neoprene	1	624-106-000
3	Adjustment Screw - O Version	1	648-575-000
	Adjustment Screw - H Version		
4	Range Springs - Normal (O)	1	
	3.5" - 6.0" WC - Red, Plated Steel		655-788-000
	5.0" - 8.5" WC - Silver, Plated Steel		655-788-001
	6.0"-14.0" WC - Blue, Plated Steel		655-788-002
	12.0"-28.0" WC - Green, Plated Steel		655-788-003
	Range Springs - High (H)		
	1 - 2 PSI - Black, Plated Steel		655-788-004
	1.5 - 3.0 PSI - Olive drab, Plated Steel		655-788-005
	2.5 - 5.5 PSI - Yellow, Plated Steel		655-788-006
	4.5 - 8.0 PSI - Brown, Plated Steel		655-788-007
Vent Assembly Parts			
5	Retaining Ring	1	693-033-000
6	Vent Screen	1	647-027-000
7	Flapper Close Spring	1	655-788-010
8	Flapper Cap	1	661-017-000
8	Flapper Disk	1	661-016-000
10	Flapper Open Spring	1	655-788-009
11	Flapper Base	1	661-015-000
12	Diaphragms	1	618-111-000
	Diaphragm - Nitrile		
13	Build Screw Nuts- Plated Steel	8	634-000-019
14	Diaphragm Plate	1	638-091-000
15	Diaphragm Pad - Rubber	1	649-646-000

Item	Description	Qty.	Part Number
16	Lower Casing - Aluminum	1	629-259-000
17	Retainer Screw	1	648-577-000
	Relief Valve Stem		648-578-000
18	Relief Valve Spring	1	655-788-008
	Retainer	1	643-226-000
19	Spring Seat	1	650-199-000
20	Pusher Post - All 301 & 301H Series	1	637-340-000
	Pusher Post - All 302 & 302H Series		637-340-001
21	Lever - Plated Steel - 3010 & 3020	1	703-012-000
	Lever - Plated Steel - 301H & 302H		703-012-001
22	Valve Stem - 3010 & 3020	1	651-107-000
	Valve Stem - 301H & 302H		651-107-001
23	Lever Pivot Pin - Stainless	1	635-084-000
24	Self Tapping Screw	2	648-576-000
25	Union Ring - Aluminum	1	644-064-000
26	Split Ring	2	644-065-000
27	O-ring	1	649-341-000
28	Throat Baffle	1	686-007-000
29	Orifices (1-1/4 + 1-1/2 NPT Bodies)		
	3/16" Aluminum	1	688-074-000
	1/4" Aluminum	1	688-074-001
	3/8" Aluminum	1	688-074-002
	1/2" Aluminum	1	688-074-003
	3/4" Aluminum	1	688-074-004
	Orifices (2 + 2 x 1.5 NPT Bodies)		
	1/4" Aluminum	1	688-016-000
	3/8" Aluminum	1	688-016-001
	1/2" Aluminum	1	688-016-002
3/4" Aluminum	1	688-016-003	
30	Seat Assembly (1-1/4 + 1-1/2 NPT Bodies)	1	650-200-000
	Seat Assembly (2 + 2 x 1-1/2 NPT Bodies)	1	822-033-000
31	Stem Guide	1	626-122-000
32	Bodies		
	1-1/4" NPT - Iron		664-576-000
	1-1/2" NPT - Iron		664-576-001
	2" NPT - Iron		664-309-000
	2" NPT - Steel	1	664-342-000
	2" x 1-1/2" - Iron		664-349-000
	2" x 1-1/2" - Steel		664-349-001
	125# FF Iron		664-377-000
150# RF Steel		665-378-000	
33	Build Screws - Plated Steel	8	648-567-003
34	Bonnet - Aluminum - All O Versions		604-274-000
	Bonnet - Aluminum - H Version / 1-2 & 1.5-3 Spring	1	800-135-000
	Bonnet - Aluminum - H Version / 2.5-5 & 4.5-8 Spring		800-135-001
35	Hex Cap Screw	1	648-066-000
36	Slip Disk	1	644-066-000
37	Body Adaptor for 2" NPT & Flanged Body Only	1	654-199-000
38	Body Adaptor O-ring for 2" NPT & Flanged Body Only	1	649-000-152

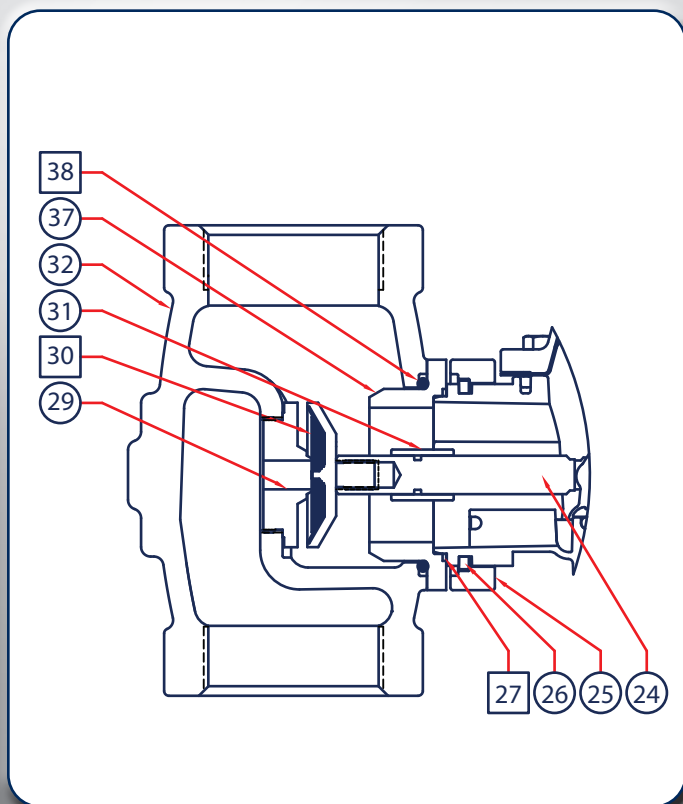

F300 Pressure Regulator

- Minimize Sudden Downstream Load Change
- Wide Pressure Ranges
- P302 has Internal Relief Valve for Overpressure Protection
- Ideal for Fix Factor Billing

The F300 series pilot operated pressure regulator is a manual, direct acting, self-operating, spring loaded, adjustable regulator. The F300 series is used in applications where pressure reduction is required. The regulator will reduce the risk of “shock” from abrupt changes of downstream conditions. This can help prevent safety equipment from shutting an operation down.

Applications

- Compressors
- Gas Engines
- Service Regulators

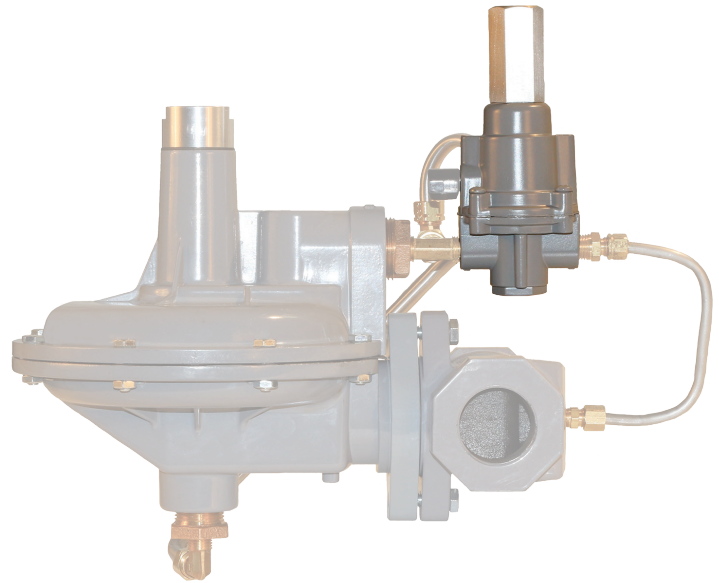

Materials of Construction

Adjusting Screw	Aluminum
Body	Ductile Iron or WCB Steel
Bonnet	Aluminum
Closing Cap	Aluminum
Diaphragm	Nitrile
Lower Casing	Aluminum
Molded Seat Assembly	Nitrile
Orifice	Aluminum
Flange	Ductile Iron / WCB Steel

F300 Series Maximum Inlet Pressure

Orifice Inches	Range	F300	
		Maximum Inlet Pressure	
		PSIG	BAR
3/16"	Any	125	8.618
1/4"	Any	125	8.618
3/8"	Any	80	5.516
1/2"	Any	60	4.137
3/4"	Any	20	1.379

Specifications

Maximum Inlet	See Table 1	
Maximum Emergency Outlet	25 PSIG	
Pressure Ranges	See Table 2	
Port Sizes	1.25 NPT	
	1.5 NPT	
	1.5 NPT x 2 NPT	
	2 NPT	
Orifice Sizes	3/16"	
	1/4"	
	3/8"	
	1/2"	
	3/4"	
End Connections	NPT	
	150 RF Flange	Steel Units Only
	125 FF Flange	Iron Units Only
Temperature Range	-20°F to 180°F	
	-29°C to 82°C	
Approx. Weight	10 lbs. (4.5 kg)	

F300 Series Range Springs

Table 2					
Model	PL84 Pilot	Spring Ranges		Pilot Spring Color	Pilot Spring Part Number
		PSIG	BAR		
F300	832-036-002	2 - 10 PSIG	0.137 - 0.689	Black	655-000-202
F300	832-036-003	2 - 20 PSIG	0.137 - 1.378	Yellow	655-000-267

F300 Part Matrix

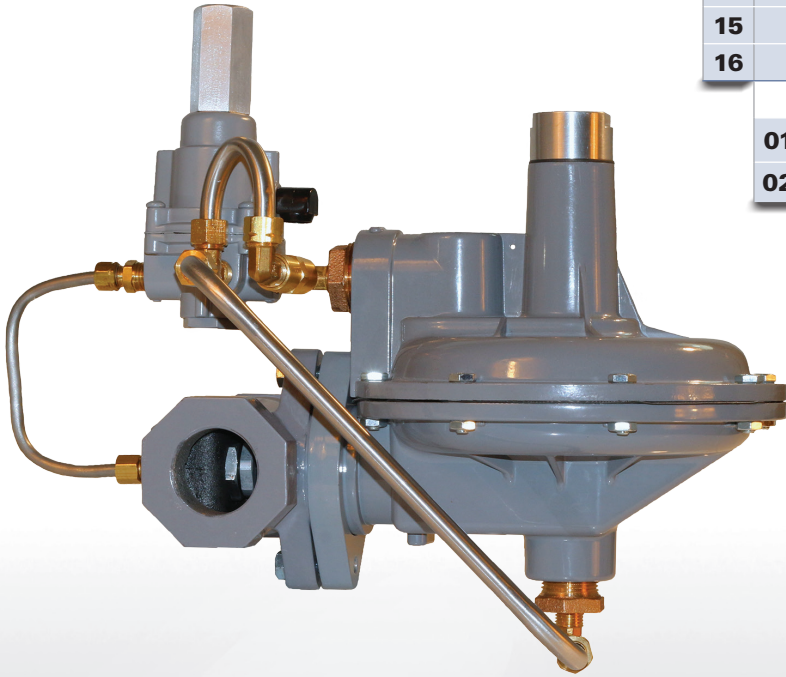

F300	▲	▲▲	▲▲▲	▲	▲	▲	▲	▲	0	
										Version
										D Internal Registration
										P External Registration
										Port Size
										12 1.25 NPT
										14 1.5 NPT
										15 1.5 x 2 NPT
										16 2 NPT
										Spring Range - WC or PSI / mBAR
										010 2 - 10 PSI / 138 - 689
										020 2 - 20 PSI / 138 - 1378
									0	Special Construction
										0 None
										A 150 RF (2" Steel Only)
										E 125 FF (2" Iron Only)
										Orifice
										3 3/16" (Only for P Version)
										4 1/4"
										6 3/8"
										8 1/2"
										B 3/4"
										Port Orientation
										3 Right
										4 Left
										Body Material
										0 Iron
										2 Steel

	Kit Includes	Part Number
F300 Regulator	Diaphragm, Disk Holder, Cap Gasket, O-Ring	971-F30-000

F200 Body Orientation*

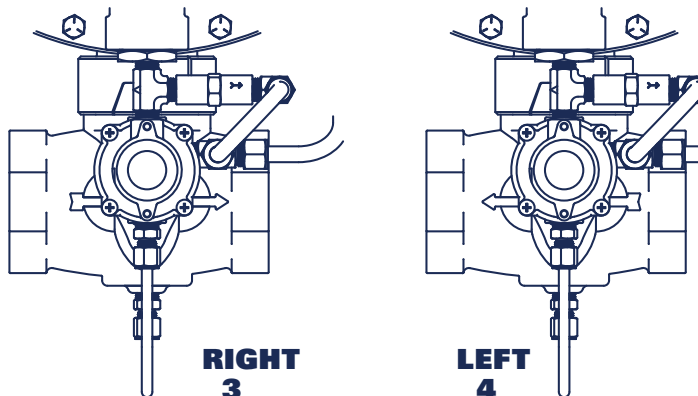

* Port orientation is based on the body's "Out" port location in relation to the top view of the regulator.

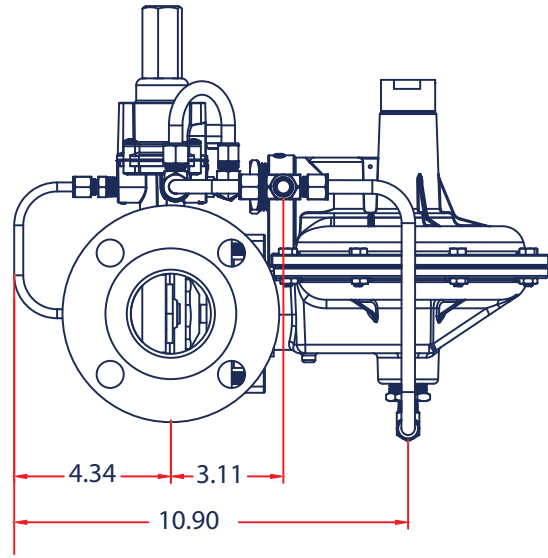
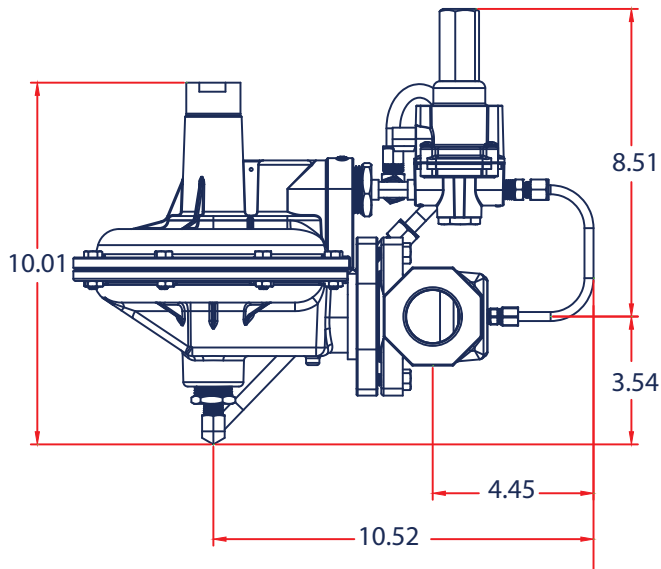
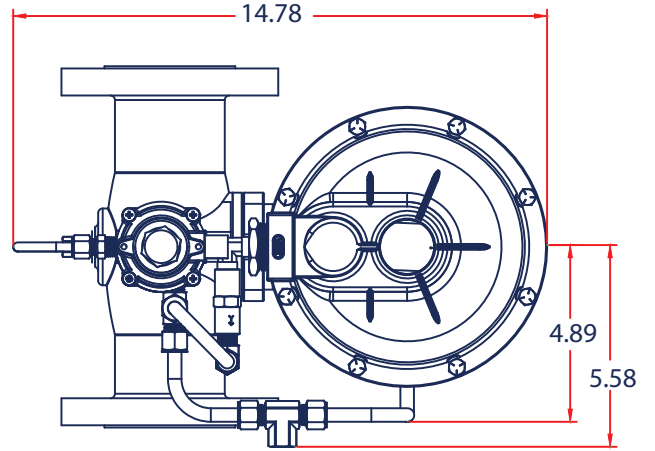
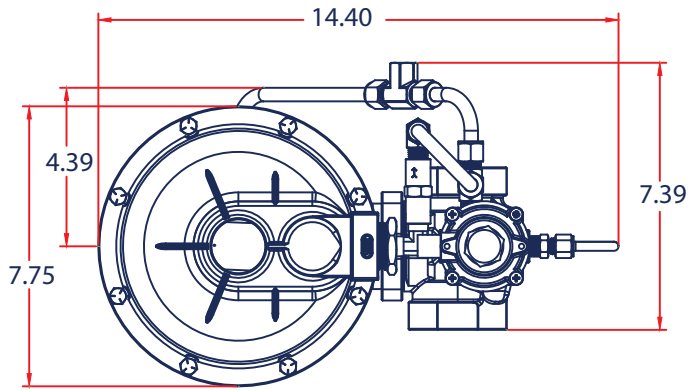

F300D flow Capacities in SCFH of 0.6 Specific Natural Gas, **Internal Registration**

Outlet Pressure, Spring Part Number, and Accuracy	Inlet Pressure		NPT 1.5 (DN40) Body Size				NPT 2.0 (DN50) Body Size			
			Orifice Size, Inches				Orifice Size, Inches			
	PSIG	BAR	1/4"	3/8"	1/2"	3/4"	1/4"	3/8"	1/2"	3/4"
2.0 PSIG Set Pressure XXX-XXX-XXX 0.5 PSIG Droop	5	0.34	800	2100	3000	5000	750	2000	3000	5000
	10	0.69	1250	3100	4800	6000	1300	3400	5000	8500
	15	1.00	1700	4200	6500	7000	1700	4300	6600	12000
	20	1.38	2000	5000	7500	7000	2100	5200	8300	14000
	30	2.10	2700	6500	9000		2750	6800	10000	
	50	3.45	4000	9000	9500		4000	9500	15000	
	60	4.10	4500	9500	9500		4700	11000	15000	
	80	5.52	5800	9500			6000	12900		
	100	6.90	7000				7000			
	125	8.60	7500				7500			
5.0 PSIG Set Pressure XXX-XXX-XXX 0.5 PSIG Droop	10	0.69	1250	3000	4200	7000	1200	3000	4000	700
	15	1.00	1700	4000	6000	7000	1700	4100	6000	10000
	20	1.38	2000	5000	7500	7000	2100	5200	7200	13000
	30	2.10	2700	7000	10000		2750	6500	10000	
	50	3.45	4000	9000	11000		4000	9500	14000	
	60	4.10	4500	10500	11000		4700	11000	16000	
	80	5.52	5800	11500			6000	13000		
	100	6.90	7000				7000			
	125	8.60	7700				8000			
10.0 PSIG Set Pressure XXX-XXX-XXX 0.5 PSIG Droop	15	1.00	1400	3000	4600	7500	1300	3200	4000	7600
	20	1.38	1800	4000	6800	7500	1900	4200	6000	10000
	30	2.10	2700	6000	9800		2600	6500	10000	
	50	3.45	4000	9000	11000		4000	9200	15000	
	50	3.45	4000	9000	11000		4000	9200	15000	
	50	3.45	4000	9000	11000		4000	9200	15000	
	100	6.90	7200				7000			
	125	8.60	8500				8300			
15.0 PSI Set Pressure XXX-XXX-XXX 0.5 PSIG Droop	20	1.38	1600	4000	5200	7500	1500	3500	5000	9000
	30	2.10	2600	6000	8500		2700	6000	8500	
	30	2.10	2600	6000	8500		2700	6000	8500	
	60	4.10	4600	10500	12000		4800	10500	17000	
	80	5.52	5900	12000			6000	13000		
	100	6.90	7200				7000			
	125	8.60	8500				8300			
20.0 PSIG Set Pressure XXX-XXX-XXX 20.0 PSI Set Pressure	30	2.10	2200	5500	7500		2400	5500	7500	
	50	3.45	3800	9500	11000		4000	9200	15000	
	60	4.10	4600	10500	13000		4800	10500	17000	
	80	5.52	5900	12000			6000	13000		
	100	6.90	7200				7000			
	125	8.60	8500				8300			

1. Limited due to boost

 - Shaded areas show where maximum operating inlet pressure for a given port diameter is exceeded.

F300P flow Capacities in SCFH of 0.6 Specific Natural Gas, External Registration

Outlet Pressure, Spring Part Number, and Accuracy	Inlet Pressure		NPT 1.5 (DN40) Body Size				
			Orifice Size, Inches				
	PSIG	BAR	3/16"	1/4"	3/8"	1/2"	3/4"
2.0 PSIG Set Pressure XXX-XXX-XXX	5	0.34	510	770	1800	2100	4250
	10	0.69	870	1450	3050	4500	8350
	15	1.00	1130	1800	3700	5650	10900
	20	1.38	1280	2150	4900	7600	13500
	30	2.10	1600	2750	6100	9100	
	50	3.45	2350	4100	9000	13500	
	60	4.10	2700	4750	10300	16100	
	80	5.52	3450	6050	12900		
	100	6.90	4300	6900			
	125	8.60	5200	8300			
5.0 PSIG Set Pressure XXX-XXX-XXX	10	0.69	650	1300	2550	3200	6500
	15	1.00	900	1500	3300	5250	9600
	20	1.38	1290	2150	4700	7450	12900
	30	2.10	1600	2750	6100	9200	
	50	3.45	2350	4100	9000	13500	
	60	4.10	2700	4750	10300	16100	
	80	5.52	3450	6050	13000		
	100	6.90	4300	6900			
0.5 PSIG Droop	125	8.60	5200	8300			
	15	1.00	700	1150	2700	4100	7200
	20	1.38	1200	1950	4100	6000	11600
	30	2.10	1600	2750	6100	9200	
	50	3.45	2350	4100	9000	13500	
	60	4.10	2700	4750	10300	16100	
	80	5.52	3450	6050	13000		
	100	6.90	4300	6900			
10.0 PSIG Set Pressure XXX-XXX-XXX	125	8.60	5200	8300			
	20	1.38	1030	1650	3050	3800	7700
	30	2.10	1500	2450	5700	7800	
	50	3.45	2350	4100	9000	13500	
	60	4.10	2700	4750	10300	16100	
	80	5.52	3450	6050	13000		
	100	6.90	4300	6900			
	125	8.60	5200	8300			
15.0 PSIG Set Pressure XXX-XXX-XXX	30	2.10	1200	2100	4700	7300	
	50	3.45	2350	4100	9000	13500	
	50	3.45	2350	4100	9000	13500	
	80	5.52	3450	6050	13000		
	100	6.90	4300	6900			
	125	8.60	5200	8300			
	0.5 PSIG Droop						
20.0 PSIG Set Pressure XXX-XXX-XXX	30	2.10	1200	2100	4700	7300	
	50	3.45	2350	4100	9000	13500	
	50	3.45	2350	4100	9000	13500	
	80	5.52	3450	6050	13000		
	100	6.90	4300	6900			
	125	8.60	5200	8300			
0.5 PSIG Droop							

1. Limited due to boost

- Shaded areas show where maximum operating inlet pressure for a given port diameter is exceeded.

F300 Parts Drawing

F300P

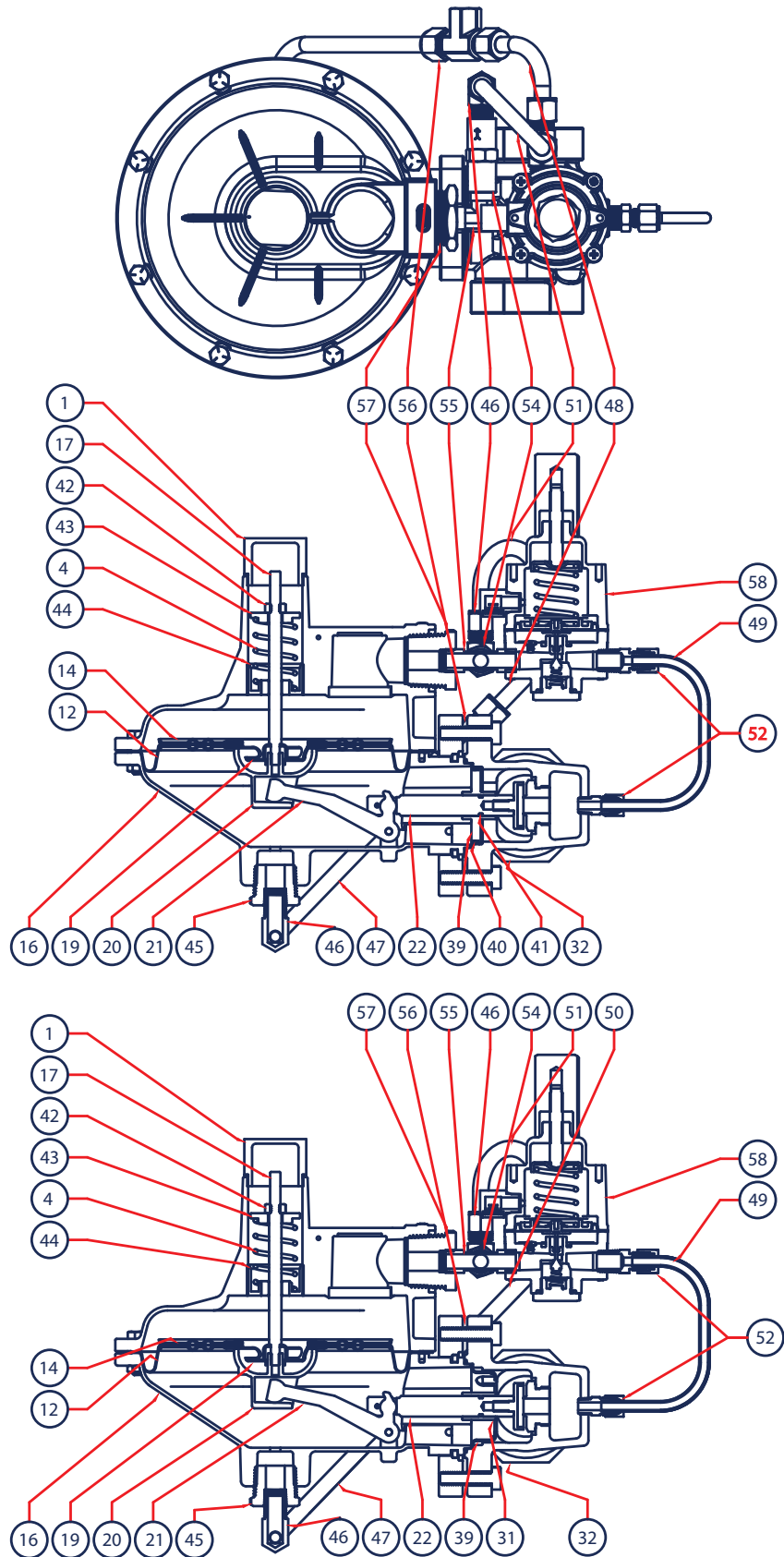

Item	Description	Qty.	Part Number
1	Closing Cap	1	610-111-000
4	Closing Spring	1	655-808-000
12	Diaphragm	1	618-111-000
14	Diaphragm Plate	2	638-091-000
16	Lower Casing - Aluminum	1	629-259-001
17	Stem	1	689-035-000
19	Diaphragm relief	1	650-199-000
20	Pusher Post, F300	1	637-340-002
21	Lever - Plated Steel - F300	1	703-012-001
22	Valve Stem - F300	1	651-107-001
28	Throat Baffle (F300D Only)	1	686-007-000
31	Stem Guide (F300D Only)	1	626-122-000
32	Body, 1-1/4 NPT	1	664-576-002
	Body, 1-1/2 NPT		664-576-003
	Body, 2" NPT - Iron		664-443-000
	Body, 2" NPT - Steel		664-443-001
	Body, 1-1/2 x 2" NPT - Iron		664-441-000
	Body, 1-1/2 x 2" NPT - Steel		664-441-001
	CL 125FF 2" - Iron		664-444-000
	CL 150RF 2" - Steel		664-444-001
34	Bonnet 0 Version	1	604-274-000
37	Body Adaptor - 2" Only	1	654-199-000
38	O-Ring - Body Adapter - 2" Only	1	649-000-152
39	Throat Block (F300P Only)	1	653-064-000
40	O-Ring - Throat Block (F300P Only)	1	649-392-000
41	O-Ring - Valve Stem (F300P Only)	1	649-269-005
42	Stem Nut	1	634-000-054
43	Spring Guide	1	626-130-000
44	Spring Seat	1	650-219-000
45	Lower Casing Bushing 3/4 x 1/4	1	622-076-000
46	Elbow 1/4 x 3/8	2	622-061-000
47	Sensing Tubing F300P Long End	1	660-149-000
48	Sensing Tubing F300P Short End	1	660-150-000
49	Pilot Supply Tubing	1	660-151-000
50	Sensing Tubing F300D	1	660-152-000
51	Relief Valve Tubing	1	660-124-000
52	Straight 1/4 X 1/4 Fitting	2	622-045-000
53	Right Angle Tee 1/4 X 3/8 X 3/8	1	622-074-000
54	Relief Valve	1	678-061-000
55	Tee M1/4 X M1/4 X M1/4	1	622-077-000
56	In-Line Tee F1/4 x 3/8 x 3/8 (F200P Only)	1	622-078-000
57	Bonnet Bushing 1 X 1/4	1	622-075-000
58	PL84 Pilot 2-10 PSI	1	832-036-002
	PL84 Pilot 2-20 PSI		832-036-003

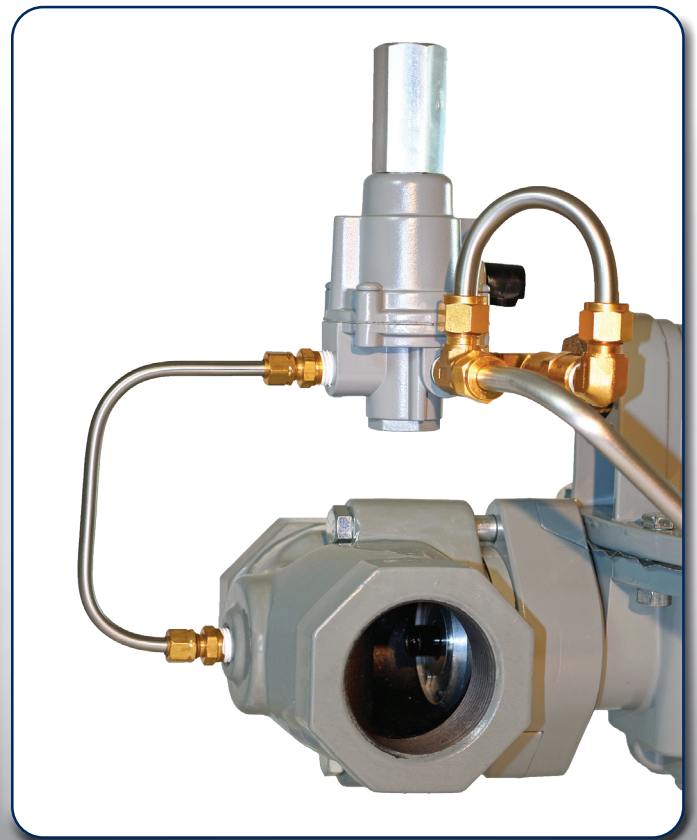
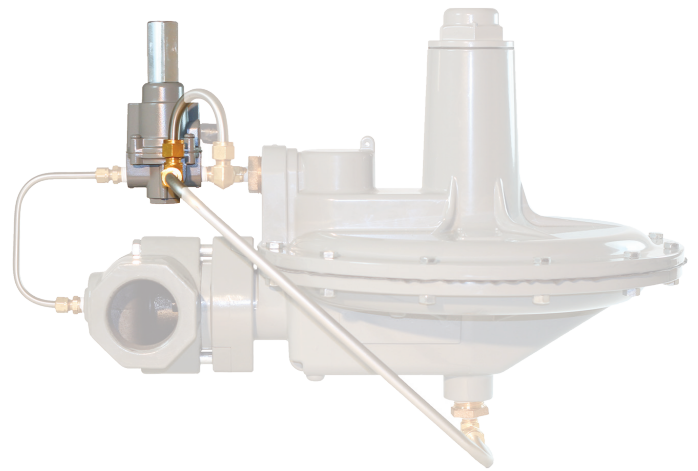

P303 Pressure Regulator

- Minimize Sudden Downstream Load Change
- Wide Pressure Ranges
- Integral Monitoring

The BelGAS P303 and P303H gas pressure reducing regulators are available with a true monitor regulator, which acts independently of the main regulator. The monitor provides equivalent overpressure protection when compared to a standard two-regulator monitor setup. Should one regulator fail, the other regulator provides control and overpressure protections.

The regulator's fast action reduces the risk of shock from abrupt changes in downstream conditions and can help to prevent safety equipment from causing unnecessary, expensive, and time-consuming operation shutdowns.

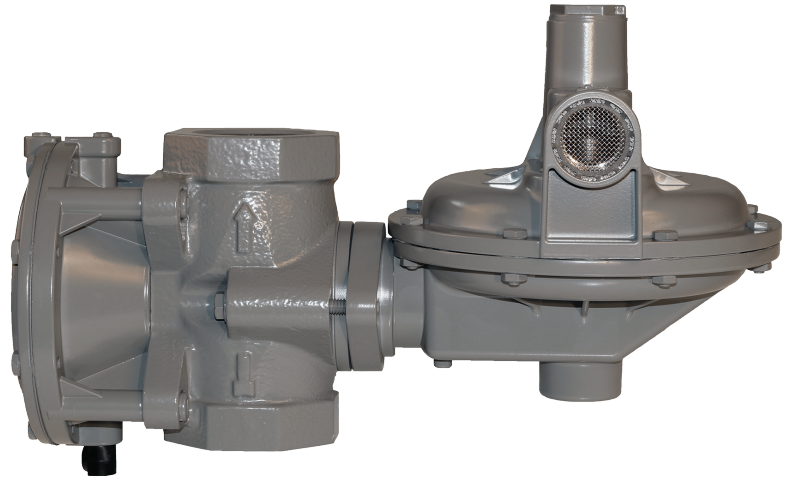

Applications

- Compressors
- Gas Engines
- Service Regulators

Materials of Construction

Adjusting Screw	Aluminum
Body	Ductile Iron
Bonnet	Aluminum
Closing Cap	Zinc
Diaphragm	Nitrile
Lower Casing	Aluminum
Molded Seat Assembly	Nitrile
Orifice	Aluminum

P303 Series Maximum Inlet Pressure

Orifice Inches	Range	P303		P303H	
		Maximum Inlet Pressure		Maximum Inlet Pressure	
		PSIG	BAR	PSIG	BAR
1/4"	Any	60	4.136	125	8.618
3/8"	Any	30	2.068	80	5.515
1/2"	Any	25	1.723	60	4.136
3/4"	Any	15	1.034	40	2.757

Specifications

Maximum Inlet	See Table 1
Maximum Emergency Outlet	15 PSIG
Pressure Ranges	See Table 2
Port Sizes	1.5 NPT
	1.5 NPT x 2 NPT
	2 NPT
Orifice Sizes	1/4"
	3/8"
	1/2"
	3/4"
End Connections	NPT
	2" 125 FF Flange

P303 Series Range Springs

Model	Spring Ranges		Spring Color	Part Number
	WC.	mBar		
P303	4 - 6 WC	9.96 - 15	Red	655-788-000
	5 - 8.5 WC	12 - 21	Silver	655-788-001
	8 - 14 WC	19.93 - 35	Blue	655-788-002
	12 - 28 WC	30 - 70	Green	655-788-003
	PSIG	Bar		
P303H	1 - 1.6 PSIG	.07 - .11	Black	655-788-004
	1.5 - 2.25 PSIG	.10 - .15	Olive	655-788-005

How Does the P303 Series Work?

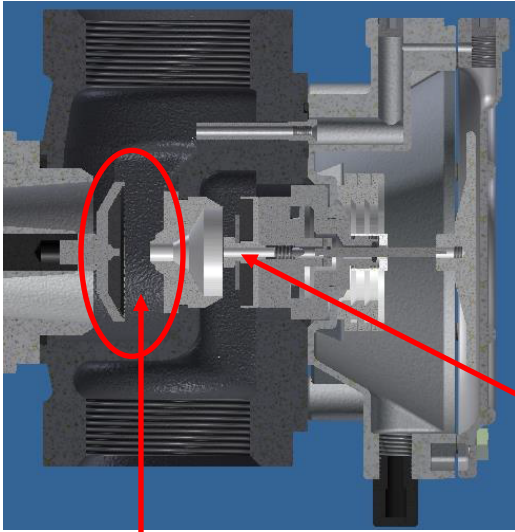

Under normal operational conditions, the P303 Series performs as the P300. When there is a demand downstream of the regulator, the main valve disk moves away from the orifice to allow flow. The Monitor diaphragm and piston are always in motion based on outlet feedback through the pitot tube at the outlet.

Secondary or monitor orifice & valve disk

Main orifice & valve disk

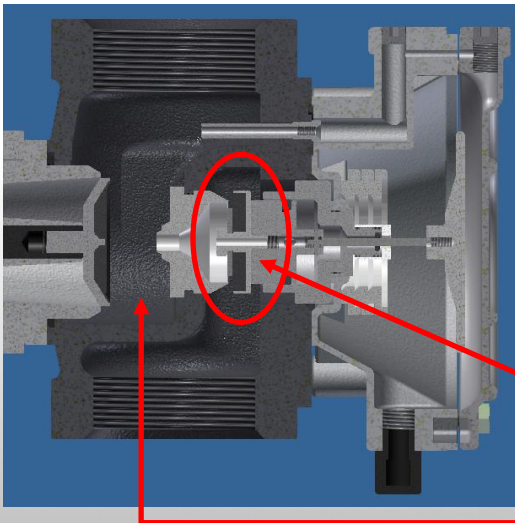

The monitor module will activate when the system experiences a failure such as the main valve disk is stuck open or the lever disengages from the valve stem assembly. When the P303 main regulator fails to regulate and the output pressure climbs, the increased output pressure will move the monitor valve disk towards the secondary sealing surface of the orifice.

Monitor valve disk starts to regulate

Main seat lodged open

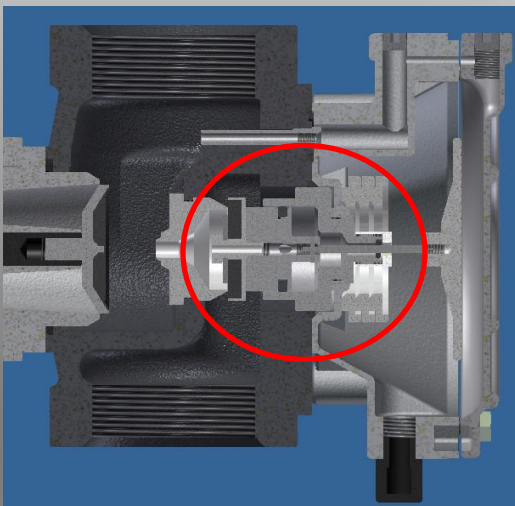

Once the output pressure has increased 7" to 28" WC above the set operating output pressure, the monitor valve disk will fully seal on the secondary sealing surface of the orifice. At this point, the only supply pressure that is passing through the unit is passing through the tiny bleed hole on the disk holder screw and venting directly out the main regulator diaphragm assembly and through the main regulator's vent assembly.

BelGAS P303 Part Number Selection

Before attempting to select a BelGAS P303, several pieces of information should be known: port size, the supply pressure the unit operates at normally, the output pressure the unit operates at normally, the downstream flow requirement during normal operation, the maximum amount of output pressure the unit is allowed to have during an over pressurization situation, and the media the unit will be regulating.

Example #1

Known Requirements

1.5 NPT
30 PSIG inlet
7" WC outlet under normal conditions
1500 SCFH 0.6 specific gravity natural gas
Should not rise above 1.3 PSIG

Port Size

The code of for 1.5 NPT in the Port Size section is 14.
P303X14XX0XXXXX

Outlet Pressure Range

It's best to operate in the middle of the range in order to preserve the life of the unit's springs. Since the output pressure is supposed to be at 7" WC during normal operation, the code for the Spring Coordination section is 85 (5 - 8.5" WC) and the code for the Version section is 0. The unit that is paired with the Spring Coordination section is the G1 option from the Monitor Range section. G1 has a range of 4-9.5" WC
P303014850XXG1

Downstream Flow Requirements

The unit needs to flow at least 1500 SCFH under normal operation with a supply pressure of 30 PSIG. According to P300 Series flow tables for that spring range and outlet pressure droop, both the 1/4" orifice and the 3/8" orifice generated more than 1500 SCFH. The 1/4" orifice generates 1700 SCFH flow of 0.6 specific gravity natural gas. The 3/8" orifice generates 2400 SCFH flow 0.6 specific gravity natural gas.
P3030148504XXG1 or P3030148506XXG1

Body and Bonnet Orientation

BelGAS offers sixteen different body/bonnet orientation combination controlled through two digits in the part number. If no special orientation is required the 3F orientation is selected.
P30301485043FG1 or P30301485063FG1

Over Pressurization Conditions

Since the unit cannot climb above 1.3 PSIG, either of the remaining orifice options will apply based on the relief curves provided.
P30301485043FG1 or P30301485063FG1

Based on the criteria provided, both regulators listed above can handle the application. However, if less pressure build up during over pressurization is desirable in this particular

function, the 1/4" will deliver a slightly lower output pressure during over pressurization.
P30301485043FG1

Example #2

Known Requirements

2" 125 FF
40 PSIG inlet
1 PSIG outlet under normal conditions
3000 SCFH air
Should not rise above 2.5 PSIG

Port Size

The code for 2" 125FF in the Port Size section is 16. In the Special Construction section, you should put code E.
P303X16XXEXXXXX

Outlet Pressure Range

It's best to operated in the middle of the range in order to preserve the life of the unit's springs. Since the output pressure is supposed to be at 1 PSIG during normal operation, the unit should be the S1 option from the Monitor Range section. S1 has a range of 1.0 - 1.6 PSIG. That means the code for the Spring Coordination section is 02 and the Version is H.
P303H1602EXXXXS1

Downstream Flow Requirements

The unit needs to flow at least 3000 SCFH under normal operation. According to the P300 Series flow tables for that spring range and outlet pressure droop, the 3/8", 1/2" and 3/4" orifices all generate more than 5000 SCFH flow of 0.6 specific gravity natural gas (which is equivalent to 3875 SCFH air).
P303H1602E6XXS1 or P303H1602E8XXS1
or P303H1602EBXXS1.

Body and Bonnet Orientation

BelGAS offers sixteen different body/bonnet orientation combination controlled through two digits in the part number. If no special orientation is required, the 3F orientaten is selected.
P303H1602E63FS1 or P303H1602E83FS1 or
P303H1602EB3FS1

Over Pressurization Conditions

Since the unit cannot climb above 2.5 PSIG, the 3/4" orifice is eliminated from the relief curves provided. Either of the remaining two orifice options will work at the supply of 40 PSIG
P303H1602E63FS1 or P303H1602E83FS1

Based on the criteria provided, both regulators listed above can handle the application. However, the 1/2" orifice will flow more than the 3/8" orifice. So if more flow during normal operation is desirable in this particular function:
P303H1602E83FS1

P303 Part Matrix

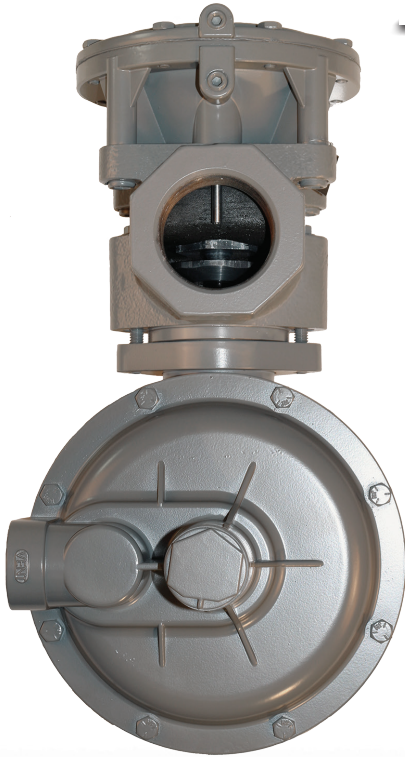

P303									
		↑	↑↑	↑↑↑	↑	↑	↑	↑	Version
O									Normal
H									High Pressure
									Port Size
	14								1.5 NPT
	15								1.5 x 2 NPT
	16								2 NPT
									Spring Range
									WC or PSIG mBAR
	06								4 - 6" WC 9.96 - 14.95 use with G1 Monitor
	85								5 - 8.5" WC 12.45 - 21.17 use with G1 Monitor
	14	0 Version Only							8 - 14" WC 19.92 - 34.87 use with G2 Monitor
	28								12" - 28" WC 29.89 - 69.74 use with R1, B1 Monitor
	02	H Version Only							1 - 1.6 PSIG 68.94 - 110.31 use with S1 Monitor
	03								1.5 - 2.25 PSIG 103.42 - 155.13 use with S2 Monitor
									Special Construction
	O								None
	E								125FF (2" Iron Only)
									Orifice
	4								1/4"
	6								3/8"
	8								1/2"
	B								3/4"
									Port Orientation
	1								Up (Standard)
	2								Down
	3								Right
	4								Left
									Bonnet Orientation
	C								12 O'clock
	D								3 O'clock (Standard)
	E								6 O'clock
	F								9 O'clock
									Monitor Range
									WC or PSIG mBAR
	G1								4 - 9.5" WC 9.96 - 23.66 use with 06 or 85 Main Spring
	G2								8 - 14" WC 19.92 - 34.87 use with 14 Main Spring
	R1								10 - 20" WC 24.90 - 49.81 use with 28 Main Spring
	B1								18 - 33" WC 44.83 - 82.19 use with 28 Main Spring
	S1								.75 - 1.6 PSIG 51.71 - 110.31 use with 02 Main Spring
	S1								1.25 - 2.25 PSIG 86.18 - 155.13 use with 03 Main Spring

Note: Monitor Range should be chosen prior to choosing Main Spring

Note: Monitor Range should be chosen prior to choosing Main Spring

P303 Regulator Rebuild Kits

	Kit Includes	Part Number
P303 Regulator	Diaphragm, Disk Holder, Cap Gasket, O-Ring	971-303-000

P303 Body Orientation*

UP
1

DOWN
2

RIGHT
3

LEFT
4

* Port orientation is based on the body's "Out" port location in relation to the top view of the regulator.

P303 Vent Positions

12
C

3
D

6
E

9
F

P303 Dimensions

Body Size	A		A2		B	C	D	
	NPT	125 FF Flange	NPT	125 FF Flange	NPT	NPT	NPT	125 FF Flange
1.5	6.13		3.06		6.66	15.14	4.61	
1.5 x 2	6.13		3.06		6.66	15.14	4.61	

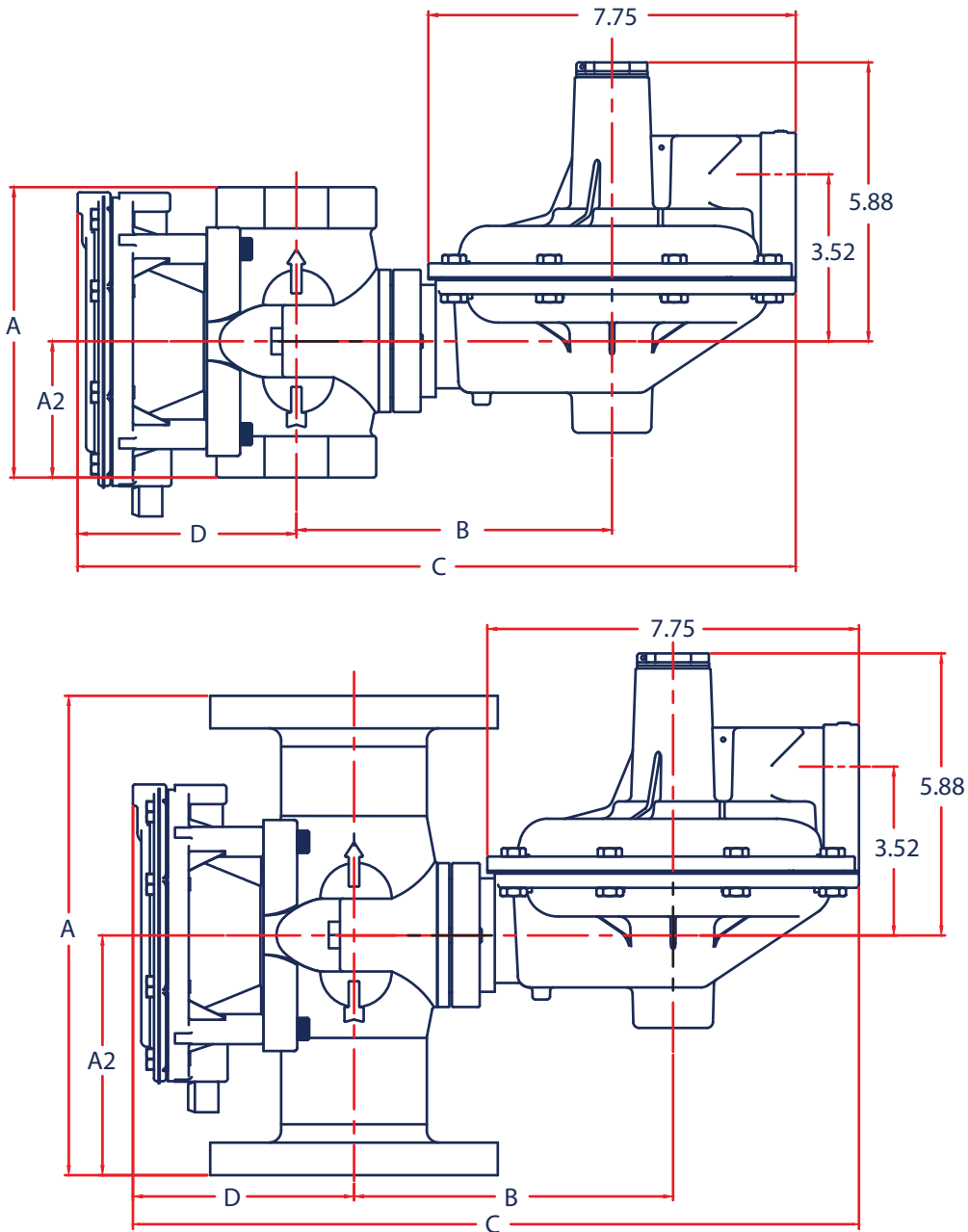

*NOTE ORIENTATIONS 1E AND 2E ARE NOT AVAILABLE WITH FLANGE BODY

P303 Relief Capacities

G1 Module Performance

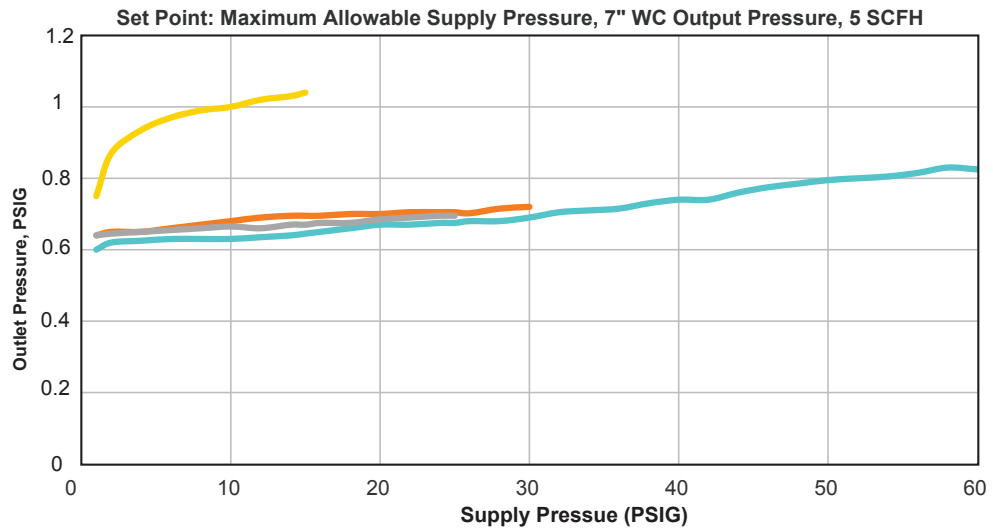

S1 Module Performance

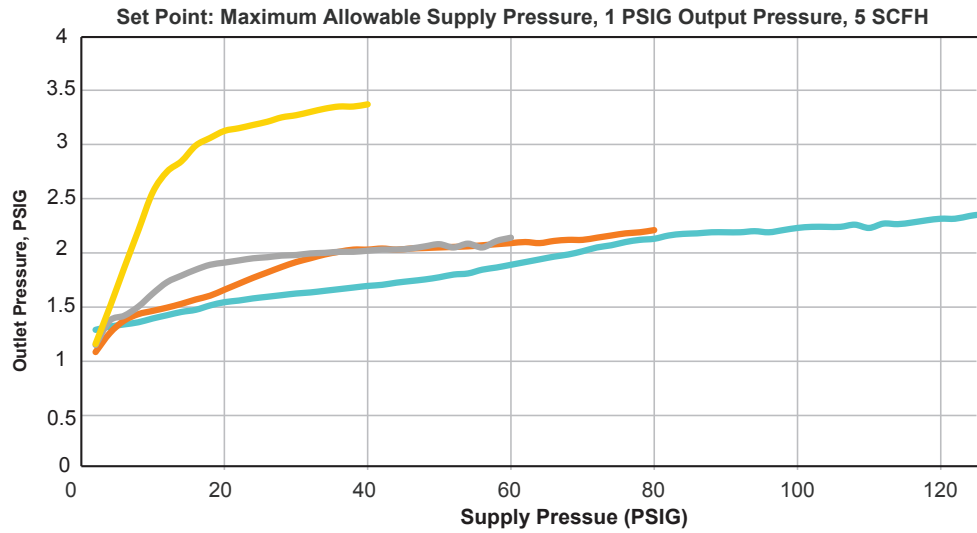

S2 Module Performance

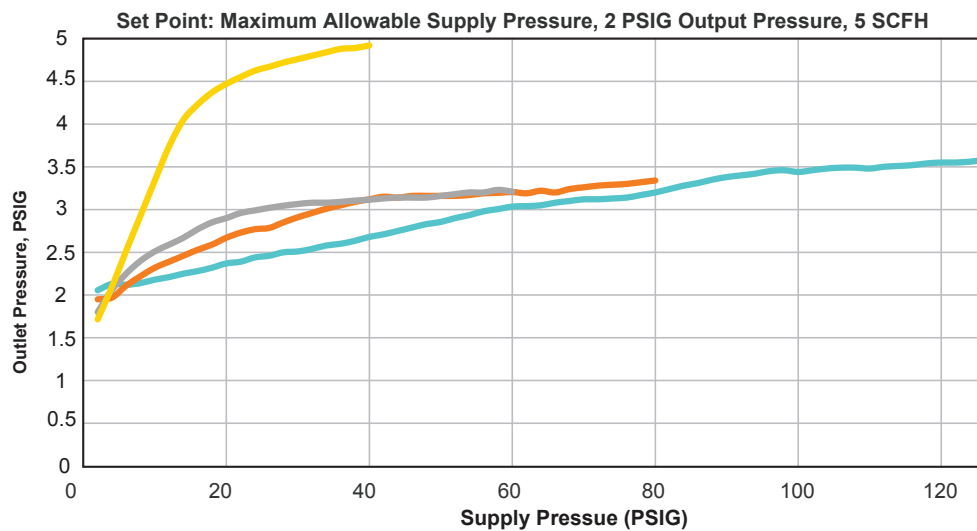

— 0.25" Orifice — 0.375" Orifice — 0.5" Orifice — 0.75" Orifice

P303 Flow Capacities in SCFH (Nm³/h) of 0.6 Specific Gravity Natural Gas

Outlet Pressure, Spring Part Number, and Accuracy	Inlet Pressure		NPT 1-1/4 (DN32) Body Size				
			Orifice Size, Inches (mm)				
	PSIG	BAR	3/16 (4.8)	1/4 (6.4)	3/8 (9.5)	1/2 (13)	3/4 (19)
5" WC Set (12 mBAR) 655-788-000 1" WC Droop	2	0.14			700 (18.8)	1000 (26.8)	1600 (42.9)
	5	0.34		700 (18.8)	1400 (37.5)	1900 (50.9)	2600 (70)
	10	0.69		1200 (32.2)	2300 (61.6)	3000 (80.4)	3500 (93.8)
	15	1.00	1050 (28.1)	1580 (42.30)	3000 (80.4)	3500 (93.8)	3500 (93.8)
	25	1.70	1400 (37.5)	2400 (64.3)	3500 (93.8)	3500 (93.8)	
	30	2.10	1550 (41.5)	2700 (72.4)	3500 (93.8)		
	60	4.10	2300 (61.6)	3500 (93.8)			
	80	5.17	3000 (80.4)				
	100	6.90	3200 (85.8)				
	125	8.60	3500 (93.8)				
7" WC Set (17 mBAR) 655-788-001 1" WC Droop	2	0.14					1400 (37.5)
	5	0.34			1100 (29.5)	1700 (45.6)	2000 (53.6)
	10	0.69		750 (20.1)	2100 (56.3)	2400 (64.3)	3500 (93.8)
	15	1.00	1000 (26.8)	1050 (28.1)	3000 (80.4)	3500 (93.8)	3500 (93.8)
	25	1.70	1250 (33.5)	1950 (52.3)	3500 (93.8)	3500 (93.8)	
	30	2.10	1500 (40.2)	2550 (68.3)	3500 (93.8)		
	60	4.10	2500 (67.0)	3500 (93.8)			
	80	5.17	2700 (72.4)				
	100	6.90	3500 (93.8)				
	125	8.60	3500 (93.8)				
11" WC Set (27 mBAR) 655-788-002 2" WC Droop	2	0.14			500 (13.4)	700 (18.8)	1200 (32.2)
	5	0.34			1100 (29.5)	1500 (40.2)	2100 (56.3)
	10	0.69			1750 (46.9)	2500 (67.0)	3500 (93.8)
	15	1.00		1200 (32.2)	2500 (67.0)	3400 (91.1)	3500 (93.8)
	25	1.70		1900 (50.9)	3500 (93.8)	3500 (93.8)	
	30	2.10	1500 (40.2)	2100 (56.3)	3500 (93.8)		
	40	2.80	1900 (50.9)	3200 (85.8)			
	60	4.10	2300 (61.6)	2620 (70.2)			
	80	5.17	2750 (73.7)				
	100	6.90	3400 (91.1)				
	125	8.60	3500 (93.8)				
	20" WC Set (50 mBAR) 655-788-003 2" WC Droop	5	0.34				1000 (26.8)
10		0.69			1150 (30.8)	1850 (49.6)	2600 (69.7)
15		1.00			1650 (44.2)	2700 (72.4)	3400 (91.1)
25		1.70		1150 (30.8)	2700 (72.4)	3500 (93.8)	
30		2.10	1200 (32.2)	1400 (37.5)	3200 (85.8)		
40		2.80	1350 (36.2)	2000 (53.6)			
60		4.10	1900 (50.9)	2900 (77.7)			
80		5.17	2600 (69.7)				
100		6.90	3000 (80.4)				
125		8.60	3500 (93.8)				

1. Limited due to boost

 - Shaded areas show where indicated droop would be exceeded regardless of capacity.

 - Shaded areas show where maximum operating inlet pressure for a given port diameter is exceeded.

P303 Flow Capacities in SCFH (Nm³/h) of 0.6 Specific Gravity Natural Gas

Outlet Pressure, Spring Part Number, and Accuracy	Inlet Pressure		NPT 1-1/2" (DN40) & 2" (DN50) Body Size				
			Orifice Size, Inches (mm)				
	PSIG	BAR	3/16 (4.8)	1/4 (6.4)	3/8 (9.5)	1/2 (13)	3/4 (19)
5" WC Set (12 mBAR) 655-788-000 1" WC Droop	2	0.14			750 (20.1)	1150 (30.8)	1700 (45.6)
	5	0.34		700 (18.8)	1550 (41.5)	2250 (60.3)	3500 (93.8)
	10	0.69		1400 (37.5)	2600 (69.7)	3500 (93.8)	3500 (93.8)
	15	1.00	1080 (28.9)	1850 (49.6)	3500 (93.8)	3500 (93.8)	3500 (93.8)
	25	1.70	1450 (38.9)	2450 (65.7)	2300 (61.6)	2600 (69.7)	
	30	2.10	1600 (42.9)	2750 (73.7)	1900 (50.9)		
	60	4.10	2600 (69.7)	3500 (93.8)			
	80	5.17	3300 (88.4)				
	100	6.90	3500 (93.8)				
	125	8.60	3500 (93.8)				
7" WC Set (17 mBAR) 655-788-001 1" WC Droop	2	0.14					1400 (37.5)
	5	0.34			1200 (26.8)	2000 (53.6)	3200 (85.8)
	10	0.69		1000 (26.8)	2400 (64.3)	3500 (93.8)	3500 (93.8)
	15	1.00	1050 (28.1)	1400 (37.5)	3300 (88.4)	3500 (93.8)	3500 (93.8)
	25	1.70	1400 (37.5)	2400 (64.3)	3500 (93.8)	2600 (69.7)	
	30	2.10	1600 (42.9)	1700 (72.4)	2400 (64.3)		
	60	4.10	2600 (69.7)	3500 (93.8)			
	80	5.17	3300 (88.4)				
	100	6.90	3500 (93.8)				
	125	8.60	3500 (93.8)				
11" WC Set (27 mBAR) 655-788-002 2" WC Droop	2	0.14			500 (13.4)	800 (21.4)	1250 (33.5)
	5	0.34			1150 (30.8)	1700 (45.6)	2500 (67.0)
	10	0.69			2000 (53.6)	3100 (83.1)	3500 (93.8)
	15	1.00		1250 (33.5)	3000 (80.4)	3500 (93.8)	3500 (93.8)
	25	1.70		195 (52.3)	3500 (93.8)	3500 (93.8)	
	30	2.10	1500 (40.2)	2300 (61.6)	3500 (93.8)		
	40	2.80	1900 (50.9)	3200 (85.8)			
	60	4.10	2650 (71.0)	3500 (93.8)			
	80	5.17	3250 (87.1)				
	100	6.90	3500 (93.8)				
125	8.60	3500 (93.8)					
20" WC Set (50 mBAR) 655-788-003 3" WC Droop	5	0.34				1050 (28.1)	1800 (48.2)
	10	0.69			1300 (34.8)	1900 (50.9)	3100 (83.1)
	15	1.00			1900 (50.9)	2850 (76.4)	3500 (93.8)
	25	1.70		1250 (33.5)	3100 (83.1)	3500 (93.8)	
	30	2.10	1300 (34.8)	1600 (42.9)	3500 (93.8)		
	40	2.80	1650 (44.2)	2200 (59.0)			
	60	4.10	2300 (61.6)	3300 (88.4)			
	80	5.17	2800 (75.0)				
	100	6.90	3200 (85.8)				
	125	8.60	3500 (93.8)				

1. Limited due to boost

- Shaded areas show where indicated droop would be exceeded regardless of capacity.
- Shaded areas show where maximum operating inlet pressure for a given port diameter is exceeded.

P303 Flow Capacities in SCFH (Nm³/h) of 0.6 Specific Gravity Natural Gas

Outlet Pressure, Spring Part Number, and Accuracy	Inlet Pressure		NPT 1-1/4 (DN32), 1-1/2 (DN40) & 2" (DN50) Body Sizes				
			Orifice Size, Inches (mm)				
	PSIG	BAR	3/16 (4.8)	1/4 (6.4)	3/8 (9.5)	1/2 (13)	3/4 (19)
1 PSIG Set (69 mBAR) 655-788-006 10% Droop	2	0.14	193 (5.2)	160 (4.3)	295 (7.9)	400 (10.7)	595 (15.9)
	5	0.34	300 (8.0)	381 (10.2)	440 (11.8)	748 (20.0)	1240 (33.2)
	10	0.69	450 (12.1)	465 (12.5)	690 (18.5)	1420 (38.1)	2200 (59.0)
	15	1.00	555 (14.9)	740 (19.8)	1290 (34.6)	2070 (55.5)	3350 (89.8)
	20	1.40	710 (19.0)	920 (24.7)	1880 (50.4)	2750 (73.7)	4500 (121.0)
	30	2.10	970 (26.0)	1160 (31.1)	3040 (81.5)	4180 (112.0)	5000 (134.0)
	40	2.80	1310 (35.1)	1620 (43.4)	4170 (112.0)	5000 (134.0)	5000 (134.0)
	60	4.10	1750 (46.9)	3300 (88.4)	5000 (134.0)	5000 (134.0)	
	80	5.17	2210 (59.2)	3400 (91.1)	5000 (134.0)		
	100	6.90	3100 (83.1)	3980 (107.0)			
	125	8.60	3760 (101.0)	3290 (88.2)			
3 PSIG Set (207 mBar) 655-788-007 10% Droop	4	0.28	303 (8.2)	207 (5.6)	478 (12.8)	548 (14.7)	1060 (28.4)
	5	0.34	374(10.0)	452 (12.1)	606 (16.2)	905 (24.3)	1290 (34.6)
	10	0.69	515 (13.8)	670 (18.0)	1130 (30.3)	1740 (46.6)	2450 (65.7)
	15	1.00	735 (19.7)	905 (24.3)	1680 (45.0)	2250 (60.3)	3230 (86.6)
	20	1.40	970 (26.0)	1030 (37.6)	2000 (53.6)	2770 (74.2)	4130 (111.0)
	30	2.10	1420 (38.1)	1755 (47.0)	2970 (79.6)	3870 (104.0)	5000 (134.0)
	40	2.80	1700 (45.6)	2200 (59.0)	4030 (108.0)	5000 (134.0)	5000 (134.0)
	60	4.10	2390 (64.1)	3070 (82.3)	5000 (134.0)	5000 (134.0)	
	80	5.17	3030 (81.2)	4000 (107.0)	5000 (134.0)		
	100	6.90	3550 (95.1)	4380 (117.0)			
	125	8.60	4180 (112.0)	4970 (133.0)			
1 PSIG Set (69 mBAR) 655-788-006 20% Droop	2	0.14	265 (7.1)	180 (4.8)	505 (13.5)	683 (18.3)	1060 (28.4)
	5	0.34	465 (12.5)	425 (11.4)	980 (26.3)	1390 (37.3)	2070 (55.5)
	10	0.69	730 (19.6)	905 (24.3)	1580 (42.3)	2270 (60.8)	3360 (90.0)
	15	1.00	1030 (27.6)	1360 (36.4)	2270 (60.3)	3160 (84.7)	4500 (121.0)
	20	1.40	1230 (86.6)	1660 (44.5)	3030 (81.2)	4000 (107.0)	5000 (134.0)
	30	2.10	1570 (42.1)	2320 (62.2)	4320 (116.0)	5000 (134.0)	5000 (134.0)
	40	2.80	1940 (52.0)	2940 (78.8)	5000/134.0)	5000 (134.0)	5000 (134.0)
	60	4.10	2650 (71.0)	4180 (112.0)	5000 (134.0)	5000 (134.0)	
	80	5.17	3230 (86.6)	4440 (119.0)	5000 (134.0)		
	100	6.90	3910 (105.0)	5000 (134.0)			
	125	8.60	4440 (119.0)	5000 (134.0)			
3 PSIG Set (207 mBar) 655-788-007 10% Droop	4	0.28	394 (10.6)	490 (13.1)	955 (25.6)	1290 (34.6)	1940 (52.0)
	5	0.34	485 (13.0)	645 (17.3)	1160 (31.1)	1610 (43.1)	2400 (64.3)
	10	0.69	825 (22.1)	1320 (35.4)	2040 (54.7)	2940 (78.8)	4260 (114.0)
	15	1.00	1060 (28.4)	1740 (46.6)	2640 (76.1)	3800 (102.0)	5000 (134.0)
	20	1.40	1250 (33.5)	2070 (55.5)	3430 (91.9)	4640 (124.0)	5000 (134.0)
	30	2.10	1570 (42.1)	2710 (72.6)	4780 (128.0)	5000 (134.0)	5000 (134.0)
	40	2.80	1940 (52.0)	3290 (88.2)	5000 (134.0)	5000 (134.0)	5000 (134.0)
	60	4.10	2630 (70.5)	4490 (120.0)	5000 (134.0)	5000 (134.0)	5000 (134.0)
	80	5.17	3290 (88.2)	5000 (134.0)	5000 (134.0)		
	100	6.90	4000 (107.0)	5000 (134.0)			
	125	8.60	4830 (129.0)	5000 (134.0)			

1. Limited due to boost

- Shaded areas show where indicated droop would be exceeded regardless of capacity.
- Shaded areas show where maximum operating inlet pressure for a given port diameter is exceeded.

P303 Parts List

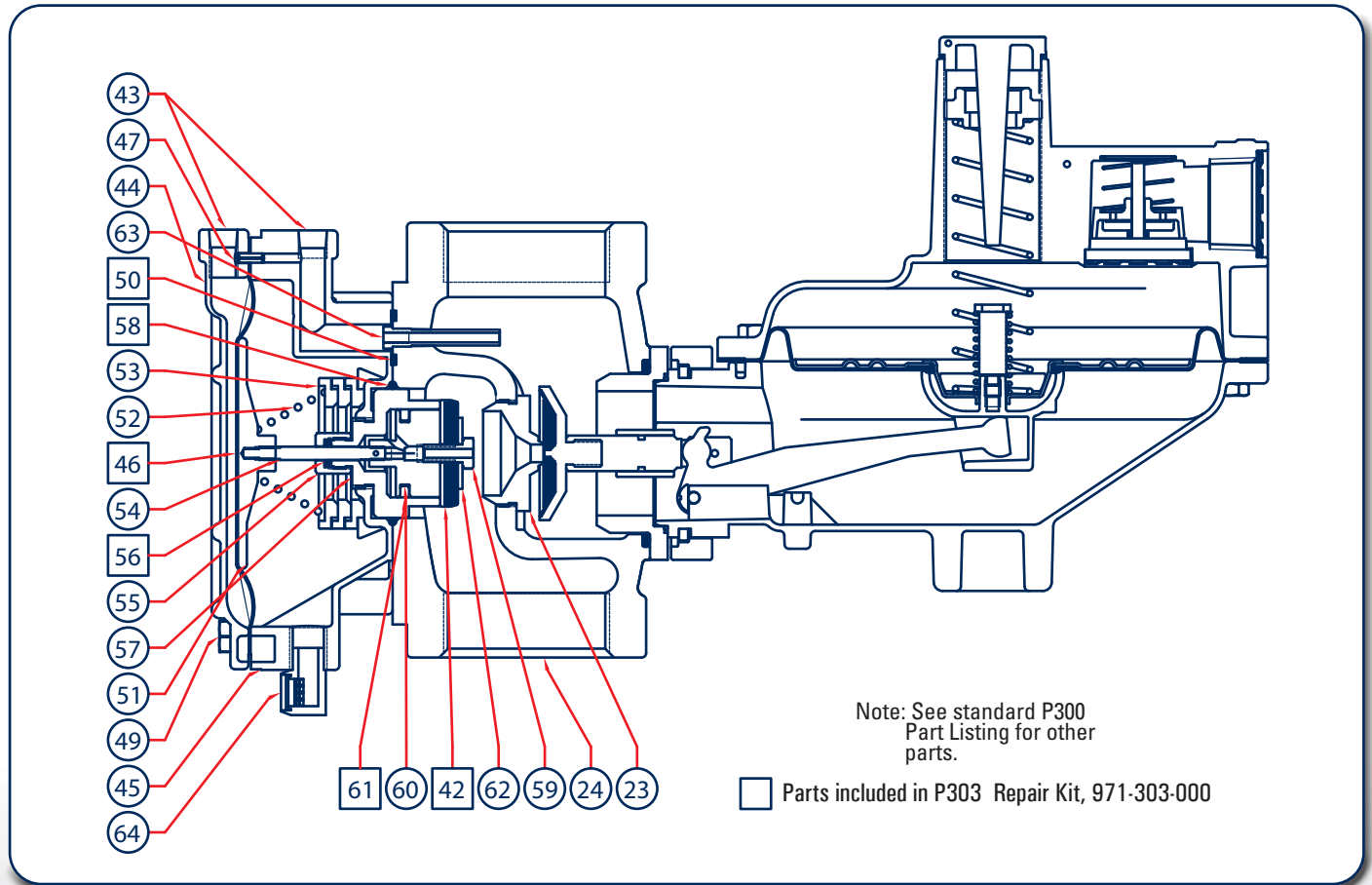

Item	Description	Qty.	Part Number
	Orifices		
23	1/4" Aluminum	1	688-061-000
	3/8" Aluminum	1	688-061-001
	1/2" Aluminum	1	688-061-002
	3/4" Aluminum	1	688-061-003
	Body		
24	Iron 1.5" NPT	1	664-396-000
	Iron 1.5" x 2" NPT	1	664-396-001
	Iron 2" NPT	1	664-384-000
	Iron 2" , 125 FF	1	664-385-000
	P303 Monitor Parts Only - See P303 for other Parts		
42	Disk Holder Assembly	1	822-044-000
43	Pipe Plug	2	639-000-054
44	Monitor Spring Case	1	604-264-000
45	Monitor Lower Case	1	629-237-000
46	Diaphragm	1	618-101-000
47	Roll Pin	1	635-074-000
48	Cap Screw (Not Shown)	4	648-466-009

Item	Description	Qty.	Part Number
	P303 Monitor Parts Only - See P300 for other Parts		
49	Cap Screw	8	648-466-000
50	O-ring	1	649-000-185
51	Diaphragm Plate	1	638-079-000
	Monitor Springs		
52	Green Spring (See Monitor Data Table)	1	655-746-000
	Red Spring (See Monitor Data Table)	1	655-746-001
	Blue Spring (See Monitor Data Table)	1	655-746-002
	Silver Spring (See Monitor Data Table)	1	655-746-003
53	Lower Spring Seat (See Monitor Data Table)	1 or 2	650-178-000
54	Piston Assembly	1	809-237-000
55	O-ring Retainer	1	643-206-000
56	Piston Assembly O-ring	1	649-000-001
57	Piston Guide	1	626-112-000
58	Piston Guide O-ring	1	649-309-003
59	Disk Holder Screw	1	648-545-000
60	Piston Ring Expander	1	644-062-000
61	Piston Ring	1	644-063-000
62	Washer	1	662-236-002
63	Pilot Tube	1	660-082-000
64	Vent Assembly	1	836-004-001

Interchangeability between the BelGAS P203 series and the P303 series

The unique feature about the BelGAS P303 regulator is that it utilizes the BelGAS P203 series bodies using a simple adaptor ring. The simplicity of down-sizing a system when a BelGAS P203 unit is installed is as easy as removing

the 2 body-to-head bolts and installing a BelGAS P303 head with the appropriate adaptor and bolts. Or, if a 1.5" x 2" or 2" x 2" BelGAS P303 is installed, the BelGAS P303 head can be removed and a BelGAS P203 head installed to up-size your system.

It is important to know, a P303 head can be mounted to a P203 2" body with the appropriate adaptor and bolts. A P200 head cannot be mounted to any existing P303 body unless confirmed to be a BelGAS 2" P203/P303 body.

Remove the BelGAS 2" P303 head

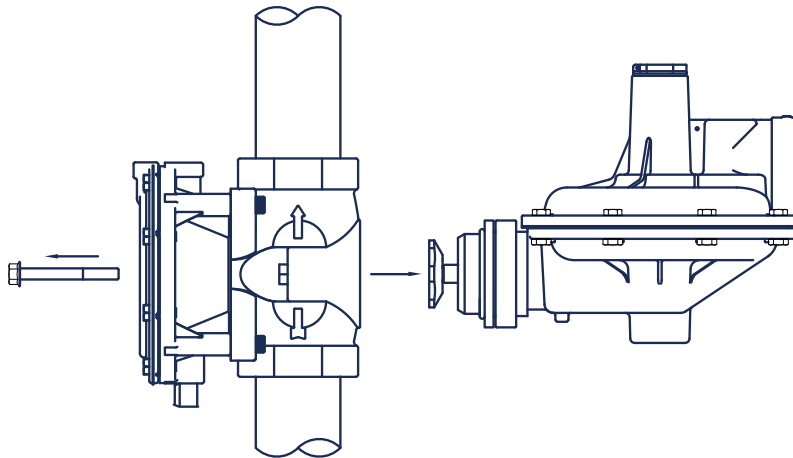

1. REMOVE BOLTS AND P303 FROM BODY, AND REMOVE FROM LINE.

Install the BelGAS P203 head

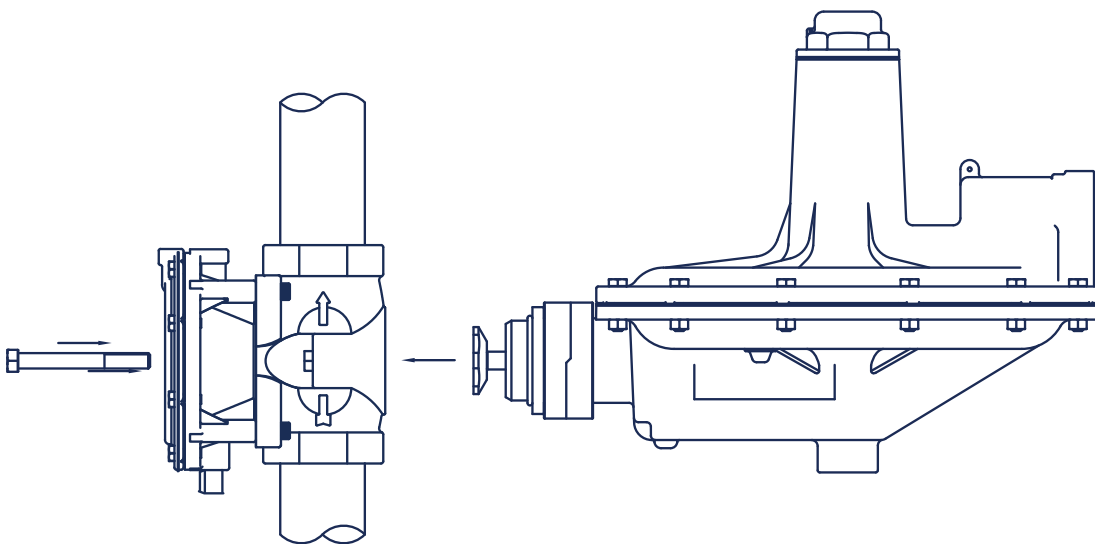

2. USE BOLTS SUPPLIED WITH HEAD ONLY VERSION TO ATTACH TO BODY ALREADY INSTALLED.