

# P200 Pressure Regulator

- Minimize Sudden Downstream Load Change
- Wide Pressure Ranges
- P202 has internal relief valve for overpressure protection

The P200 series pressure regulator is a manual, direct acting, self-operating, spring loaded, adjustable regulator. The P200 series is used in applications where pressure reduction is required. The regulator will reduce the risk of “shock” from abrupt changes of downstream conditions. This can help prevent safety equipment from shutting an operation down.

## Applications

- Compressors
- Gas Engines
- Service Regulators



## Materials of Construction

Adjusting Screw	Aluminum / Zinc Plated Steel
Body	Ductile Cast Iron or WCB Steel
Bonnet	Aluminum
Closing Cap	Aluminum / Brass
Diaphragm	Nitrile
Lower Casing	Aluminum
Molded Seat Assembly	Nitrile
Orifice	Aluminum
Upper/Lower Spring Seat	Aluminum / Brass
Flange	Ductile Iron / WCB Steel

## Specifications

Maximum Inlet	See Table 1	
Maximum Emergency Outlet	15 PSIG	
Pressure Ranges	See Table 2	
Port Sizes	1.25 NPT	
	1.5 NPT	
	1.5 NPT x 2 NPT	
	2 NPT	
Orifice Sizes	1/4"	
	3/8"	
	1/2"	
	3/4"	
	1"	
	1-3/16"	
End Connections	NPT	
	150 RF Flange	Steel Units Only
	125 FF Flange	Iron Units Only
Temperature Range	-20°F to 180°F	
	-29°C to 82°C	
Approx. Weight	26 lbs. (11.8 kg)	

## P200 Series Maximum Inlet Pres-

Orifice Inches	Range	Maximum Inlet Pressure	
		PSIG	BAR
1/4"	Any	125	8.618
3/8"	Any	125	8.618
1/2"	Any	100	6.894
3/4"	Any	60	4.136
1"	2-4.5" thru 14-30" WC	25	1.723
	1-2 thru 4-10 PSIG	30	2.068
1-3/16"	2-4.5" thru 14-30" WC	13	0.896
	1-2 thru 1.5-3.25 PSIG	14	0.965
	2-5 thru 2-5.5 PSIG	20	1.378
	4-10 PSIG	25	1.723

## P200 Series Range Springs

Model	Spring Ranges		Spring Color	Part Number
	W.C. or PSI	Bar		
P201 P202 P201S P202S	2 - 4.5 WC	0.005 - 0.011	Brown	655-697-002
	3.5- 6.5 WC	0.009 -0.016	Red	655-697-003
	5 - 9 WC	0.012 - 0.022	Black	655-697-004
	6 - 14 WC	0.015 - 0.035	Purple	655-697-011
	8.5 - 18 WC	0.021 - 0.045	White	655-697-005
	14 - 30 WC	0.035 - 0.075	Dark Green	655-697-006
P201H P202H P201S P202S	1 - 2 PSIG	0.069 - 0.138	Dark Blue	655-697-007
	1.5 - 3.25 PSIG	0.103 - 0.224	Orange	655-697-008
	2 - 5 PSIG	0.138 - 0.345	Yellow	655-697-009
P201K P201S	2 - 5.5 PSIG	0.138 - 0.379	Green	655-659-003
	4 - 10 PSIG	0.276 - 0.689	Grey	655-697-010

## P200 Regulator Rebuild Kits

	Kit Includes	Part Number
P200 O & H Ranges	Diaphragm, disk holder assembly, cap gasket and body/ lower casing o-ring	971-200-000
P200 K Ranges	Diaphragm, disk holder assembly, cap gasket and body/ lower casing o-ring	971-200-001
P200 All Units	Stabilizer Kit for Downstream Dampening	971-200-004

## P200 Dimensions

Body Size	A			B	C	D		
	Inches	NPT	125 FF Flange			150 RF Flange	NPT	125 FF Flange
1.25	6.13			11.03	18.09	1.85		
1.5	6.13		10	11.03	18.09	1.85		1.85
1.5 x 2	6.13			11.03	18.09	1.85		

### P200 Standard

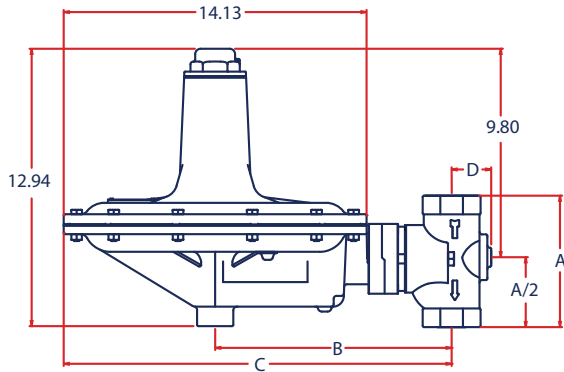

### P200 Flanged

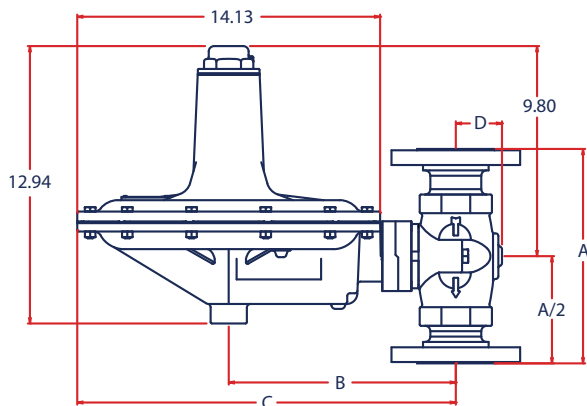

## P200 Part Matrix

P200	↑	↑	↑	↑	↑	↑	↑	Version
<b>1</b>								Non-Relieving
<b>2</b>								Relieving
								Configuration
<b>O</b>								Normal
<b>H</b>								High
<b>K</b>								Heavy
<b>S</b>								Throat Stabilizer
								Port Size
<b>12</b>								1.25 NPT
<b>14</b>								1.5 NPT
<b>15</b>								1.5 x 2 NPT
<b>16</b>								2 NPT
								Spring Range - WC or PSI / mBAR
<b>004</b>								2 - 4.5" WC 4.98 - 11.20
<b>006</b>								3.5 - 6.5" WC 8.71 - 16.19
<b>009</b>								5 - 9" WC 12.45 - 22.41
<b>014</b>								6 - 14" WC 14.94 - 34.87
<b>018</b>								8.5 - 18" WC 21.17 - 44.83
<b>030</b>								14 - 30" WC 34.87 - 74.72
<b>002</b>								1 - 2 PSIG 68.94 - 137.89
<b>003</b>								1.5 - 3.25 PSIG 103.42 - 224.07
<b>005</b>								2 - 5 PSIG 137.89 - 344.73
<b>K05</b>								2 - 5.5 PSIG 137.89 - 379.21
<b>010</b>								4 - 10 PSIG 275.79 - 689.47
								Special Construction
<b>O</b>								None
<b>A</b>								150 RF (1.5" & 2" Steel Only)
<b>E</b>								125 FF (2" Iron Only)
								Orifice
<b>4</b>								1/4"
<b>6</b>								3/8"
<b>8</b>								1/2"
<b>B</b>								3/4"
<b>D</b>								1"
<b>F</b>								1-3/16"
								Port Orientation
<b>1</b>								Up (Standard)
<b>2</b>								Down
<b>3</b>								Right
<b>4</b>								Left
								Bonnet Orientation
<b>C</b>								12 O'Clock
<b>D</b>								3 O'Clock (Standard)
<b>E</b>								6 O'Clock
<b>F</b>								9 O'Clock
								Body Material
<b>O</b>								Iron
<b>2</b>								Steel

## P200 Head Only

P20				0	
					Version
<b>1</b>					Non-Relieving
<b>2</b>					Relieving
					Configuration
<b>0</b>					Normal
<b>H</b>					High
<b>K</b>					Heavy
<b>S</b>					Throat Stabilizer
<b>P</b>					Spring Range - WC or PSIG / mBAR
<b>004</b>					2 - 4.5" WC    4.98 - 11.20
<b>006</b>					3.5 - 6.5" WC    8.71 - 16.19
<b>009</b>					5 - 9" WC    12.45 - 22.41
<b>014</b>					6 - 14" WC    14.94 - 34.87
<b>018</b>					8.5 - 18" WC    21.17 - 44.83
<b>030</b>					14 - 30" WC    34.87 - 74.72
<b>002</b>					1 - 2 PSIG    68.94 - 137.89
<b>003</b>					1.5 - 3.25 PSIG    103.42 - 224.07
<b>005</b>					2 - 5 PSIG    137.89 - 344.73
<b>K05</b>					2 - 5.5 PSIG    137.89 - 379.21
<b>010</b>					4 - 10 PSIG    275.79 - 689.47
					H or S Version Only
					K or S version Only
					Special Construction
<b>0</b>					None
					Bonnet Orientation
<b>C</b>					12 O'Clock
<b>D</b>					3 O'Clock (Standard)
<b>E</b>					6 O'Clock
<b>F</b>					9 O'Clock
					Trim Material
<b>0</b>					Nitrile



## P200 Body Orientation\*

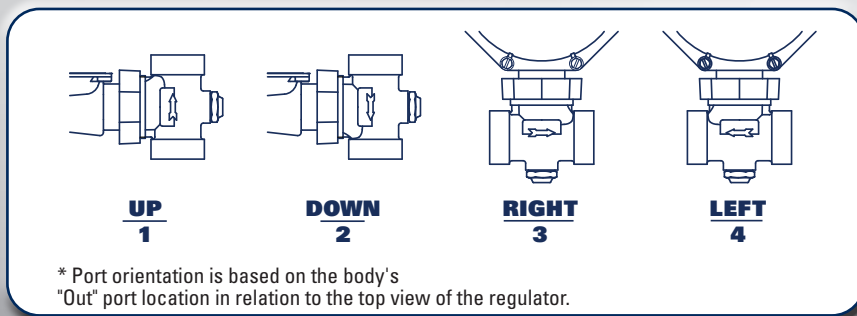

## P200 Vent Positions

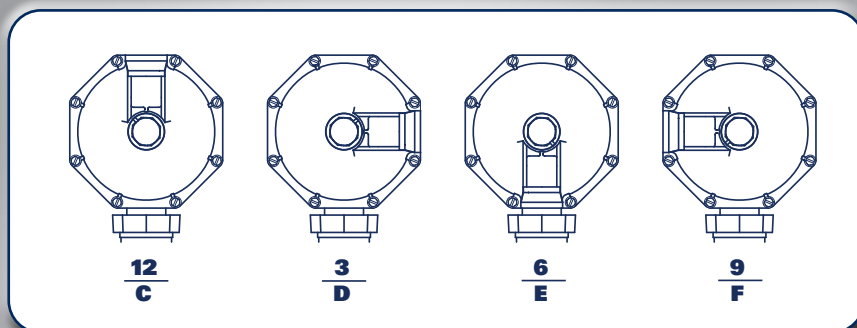

## P202 Normal (0) Relief Capacities

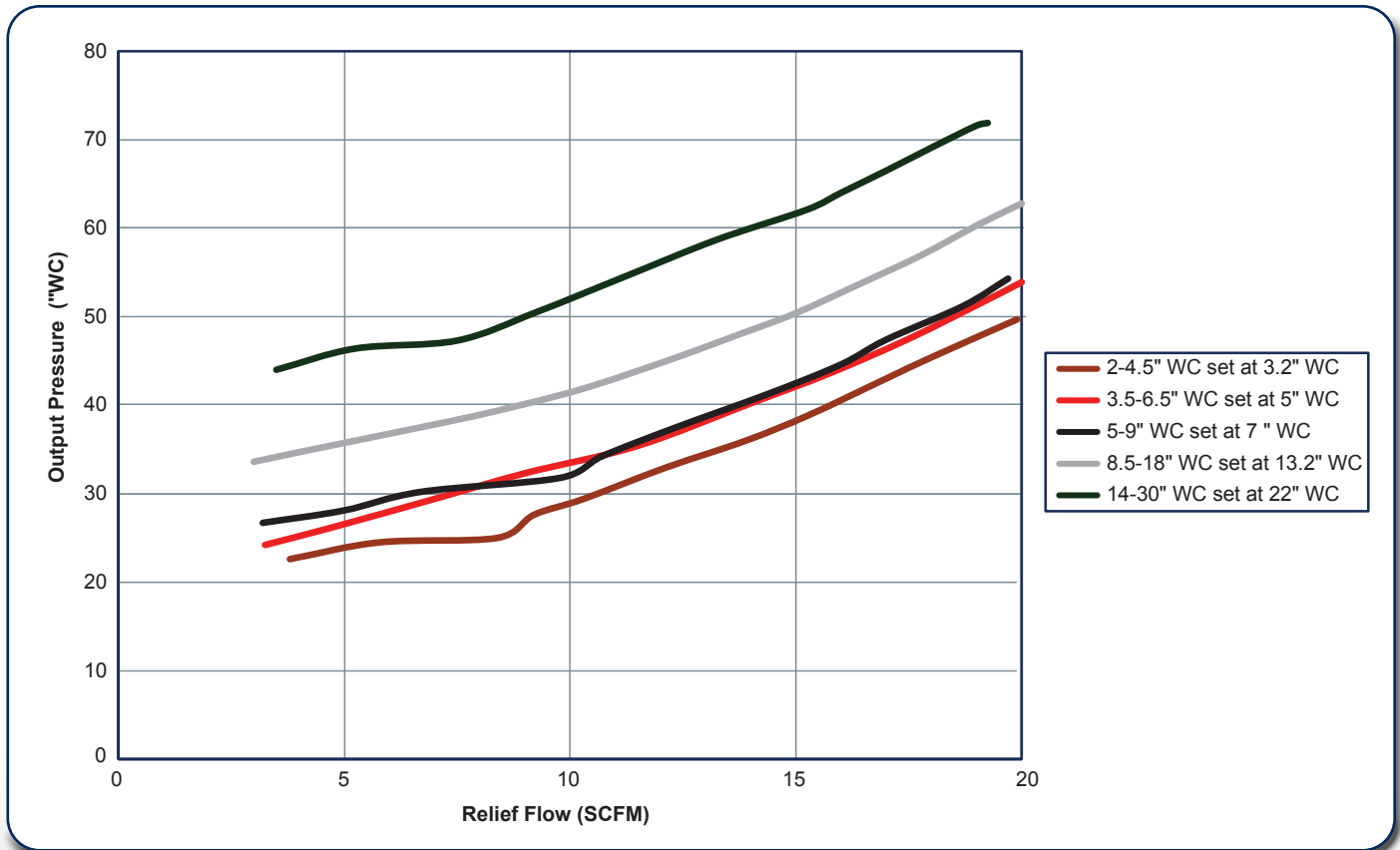

## P202 High (H) Relief Capacities

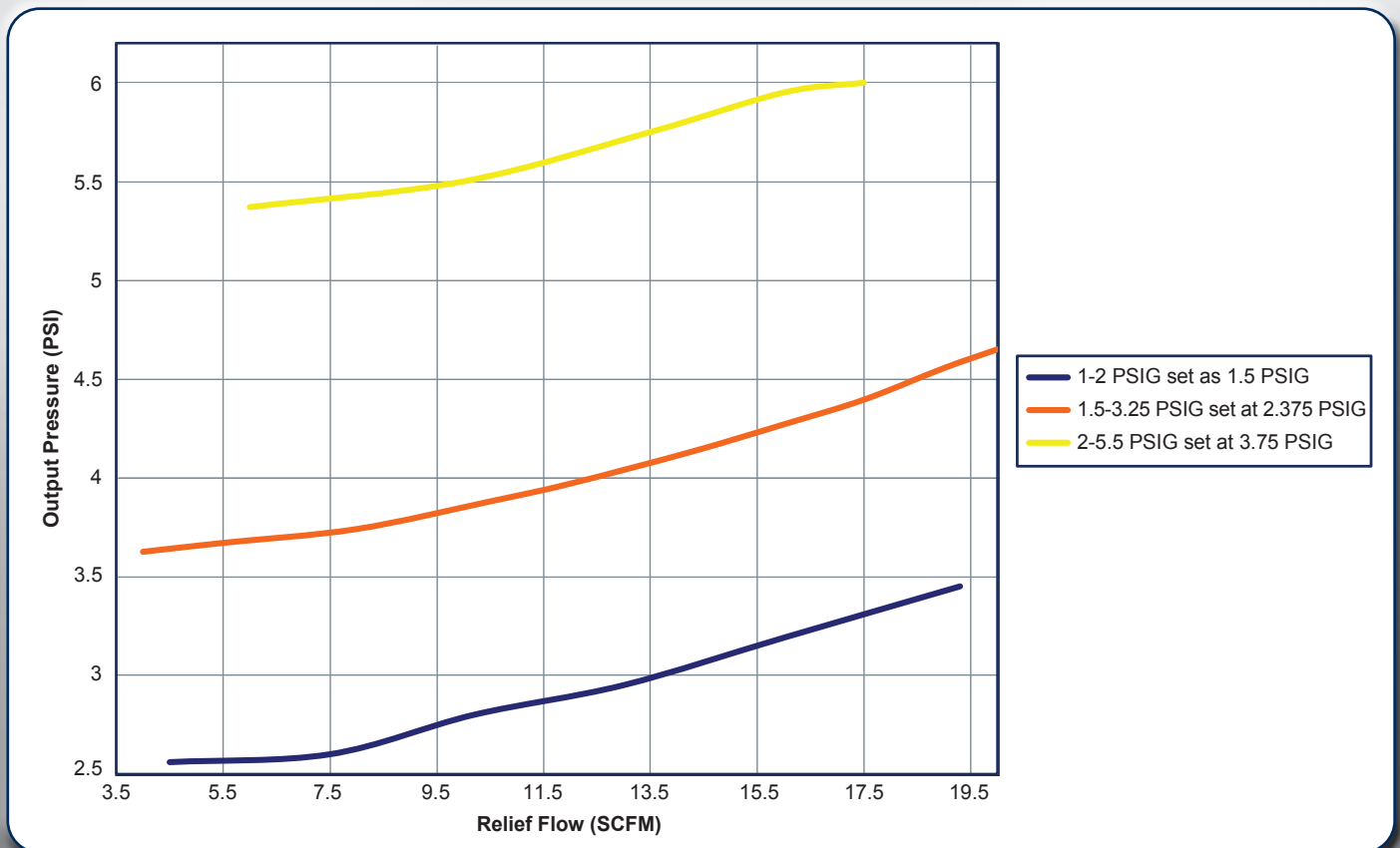

**P200 Flow Capacities in SCFH** (Nm<sup>3</sup>/h) of 0.6 Specific Gravity Natural Gas



Outlet Pressure, Spring Part Number, and Accuracy	Inlet Pressure		NPT 1-1/2 Body Size					
			Orifice Size, Inches (mm)					
	PSIG	BAR	1/4 (6.4)	3/8 (9.5)	1/2 (13)	3/4 (19)	1 (25)	1-3/16 (30)
4 inches w.c. (10 mbar) 655-697-002 or 655-697-003 1 inch w.c. (2 mbar) droop 2 inches w.c. (5 mbar) boost	0.4	0.028				1000 (26.8)	1400 (37.5)	1600 (42.8)
	0.5	0.034				1400 (37.5)	1600 (42.8)	1800 (48.2)
	1	0.07	400 (10.7)	800 (21.4)	1200 (32.2)	2100 (56.3)	2500 (67.0)	2700 (72.4)
	1.5	0.10	500 (13.4)	1050 (28.1)	1600 (42.9)	2500 (67.0)	3000 (80.4)	3200 (85.8)
	2	0.14	600 (16.1)	1300 (34.8)	2100 (56.3)	2800 (75.0)	3500 (93.8)	3800 (102)
	5	0.34	1150 (30.8)	2200 (58.9)	3300 (88.4)	4500 (121)	5300 (142)	6000 (161)
	13	0.90	1600 (42.8)	3600 (96.4)	6200 (166)	7000 (188)	6000 (161)	6850 (184)
	25	1.7	2550 (68.3)	5000 (134)	7350 (197)	8950 (240)	9000 (241)	
	60	4.1	4750 (127)	5100 (137)	7050 (189)	5600 (150) <sup>(1)</sup>		
	100	6.9	6650 (186)	7300 (196)	5200 (139) <sup>(1)</sup>			
125	8.6	6950 (1)	8300 (222)					
7 inches w.c. (17 mbar) 655-697-004 1 inch w.c. (2 mbar) droop 2 inches w.c. (5 mbar) boost	0.4	0.028				900 (24.1)	1300 (34.8)	1450 (38.9)
	0.5	0.034				1200 (32.2)	1550 (41.5)	1750 (46.9)
	1	0.07	400 (10.7)	800 (21.4)	1100 (29.5)	1900 (50.9)	2300 (61.6)	2500 (67.0)
	1.5	0.10	500 (13.4)	1050 (28.1)	1500 (40.2)	2300 (61.6)	2800 (75.0)	1800 (48.2)
	2	0.14	600 (16.1)	1300 (34.8)	1900 (50.9)	2100 (56.3)	3300 (88.4)	1800 (48.2)
	5	0.34	950 (25.5)	2100 (56.3)	3200 (85.8)	3350 (89.8)	5100 (137)	4500 (121)
	13	0.90	1600 (42.8)	2200 (58.9)	3300 (88.4)	5800 (155)	8000 (214)	8000 (214)
	25	1.7	2200 (58.9)	5200 (139)	6800 (182)	8400 (225)	8750 (235)	
	60	4.1	4300 (115)	9200 (247)	10100 (271)	9900 (265)		
	100	6.9	7500 (201)	10500 (281)	9200 (247) <sup>(1)</sup>			
125	8.6	9050 (243)	9800 (263) <sup>(1)</sup>					
11 inches w.c. (27 mbar) 655-697-005 ± 2 inches w.c. (5 mbar)	0.5	0.03				800 (21.4)	1500 (40.2)	1700 (45.6)
	1	0.07	400 (10.7)	700 (18.7)	1100 (29.5)	1800 (48.2)	2200 (58.9)	2450 (65.7)
	1.5	0.10	500 (13.4)	950 (25.5)	1450 (38.9)	2300 (61.6)	2800 (75.0)	2600 (69.7)
	2	0.14	600 (16.1)	1200 (32.2)	1700 (45.6)	1950 (52.3)	3200 (85.8)	2750 (73.7)
	5	0.34	950 (25.5)	2000 (53.6)	2900 (77.7)	3800 (102)	5100 (137)	5150 (138)
	13	0.90	1600 (42.8)	3400 (91.1)	3700 (99.2)	6100 (163)	7250 (194)	7650 (205)
	25	1.7	2100 (56.3)	5150 (138)	7100 (190)	7950 (213)	9400 (252)	
	60	4.1	4400 (118)	9250 (248)	9400 (252)	10400 (279)		
	100	6.9	7300 (196)	10000 (268)	10100 (271)			
	125	8.6	9050 (243)	10800 (289)				
14 inches w.c. (35 mbar) 655-697-005 ± 2 inches w.c. (5 mbar)	1	0.07	450 (12.1)	800 (21.4)	1000 (26.8)	1250 (33.5)	1500 (40.2)	1950 (52.3)
	1.5	0.10	500 (13.4)	850 (22.8)	1050 (28.1)	1550 (41.5)	1650 (44.2)	2350 (62.9)
	2	0.14	550 (14.7)	1150 (30.8)	1400 (37.5)	1750 (46.9)	2300 (61.6)	2500 (67.0)
	5	0.34	1000 (26.8)	1200 (32.2)	2050 (54.9)	3000 (80.4)	4300 (115)	4750 (127)
	13	0.90	1750 (46.9)	3050 (81.7)	4250 (114)	6100 (163)	7300 (196)	7850 (210)
	25	1.7	2500 (67.0)	4750 (127)	5650 (151)	8700 (233)	8700 (233)	
	60	4.1	4750 (127)	9450 (253)	9950 (267)	10550 (283)		
	100	6.9	7450 (200)	10400 (279)	10600 (284)			
	125	8.6	9050 (243)	10450 (280)				
	20 inches w.c. (50 mbar) 655-697-006 ± 3 inches w.c. (7 mbar)	1	0.07	300 (8.04)	500 (13.4)	750 (20.1)	1000 (26.8)	1300 (34.8)
2		0.14	500 (13.4)	950 (25.5)	1400 (37.5)	2000 (53.6)	2800 (75.0)	3100 (83.1)
5		0.34	900 (24.1)	1700 (45.6)	2500 (67.0)	4200 (113)	5000 (134)	5500 (147)
13		0.90	1500 (40.2)	3200 (85.8)	5400 (145)	6500 (174)	7000 (188)	7100 (190)
25		1.7	2100 (56.3)	4700 (126)	7000 (188)	8250 (221)	9350 (251)	
60		4.1	4750 (127)	8900 (239)	9950 (267)	10600 (284)		
100		6.9	7400 (198)	10500 (281)	10800 (289)			
125		8.6	9200 (247)	10950 (293)				

1. Limited due to boost

- Shaded areas show where indicated droop would be exceeded regardless of capacity.
- Shaded areas show where maximum operating inlet pressure for a given port diameter is exceeded.

**P200 Flow Capacities in SCFH** (Nm<sup>3</sup>/h) of 0.6 Specific Gravity Natural Gas

Outlet Pressure, Spring Part Number, and Accuracy	Inlet Pressure		NPT 2 (DN 50) Body Size					
			Orifice Size, Inches (mm)					
	PSIG	BAR	1/4 (6.4)	3/8 (9.5)	1/2 (13)	3/4 (19)	1 (25)	1-3/16 (30)
4 inches w.c. (10 mbar) 655-697-002 or 655-697-003 1 inch w.c. (2 mbar) droop 2 inches w.c. (5 mbar) boost	0.4	0.028				1200 (32.3)	1600 (42.8)	1800 (48.2)
	0.5	0.034				1700 (45.6)	2200 (58.9)	2400 (64.3)
	1	0.07	400 (10.7)	900 (24.1)	1300 (34.8)	2800 (75.0)	3200 (85.8)	3800 (102)
	1.5	0.10	500 (13.4)	1100 (29.5)	1700 (45.5)	3600 (96.5)	4300 (115)	5000 (134)
	2	0.14	600 (16.1)	1400 (37.5)	2200 (58.9)	4500 (121)	5500 (147)	6400 (172)
	5	0.34	1000 (26.8)	2300 (61.6)	3700 (99.2)	7800 (209)	9500 (255)	12700 (340)
	13	0.90	1650 (44.2)	3700 (99.2)	6500 (174)	13000 (348)	14000 (375)	14500 (389)
	25	1.7	2500 (64.3)	5200 (139)	9200 (247)	13000 (348)	18000 (482)	
	60	4.1	4450 (119)	9000 (241)	14550 (390)	15000 (402)		
	100	6.9	5500 (147)	9500 (255)	12900 (346) <sup>(1)</sup>			
125	8.6	7250 (194)	3900 (105) <sup>(1)</sup>					
7 inches w.c. (17 mbar) 655-697-004 1 inch w.c. (2 mbar) droop 2 inches w.c. (5 mbar) boost	0.4	0.028				950 (25.5)	1400 (37.5)	1600 (42.8)
	0.5	0.034				1500 (40.2)	1800 (48.2)	2000 (53.6)
	1	0.07	400 (10.7)	800 (21.4)	1200 (32.2)	2300 (61.6)	2800 (75.0)	3300 (88.4)
	1.5	0.10	500 (13.4)	1050 (28.1)	1600 (42.8)	3100 (83.1)	3600 (96.5)	4500 (121)
	2	0.14	600 (16.1)	1300 (34.8)	2000 (53.6)	4000 (107)	4500 (121)	6000 (161)
	5	0.34	1000 (26.8)	2100 (56.3)	3500 (93.8)	7700 (206)	9400 (252)	9400 (252)
	13	0.90	1650 (44.2)	3500 (93.8)	6400 (172)	10000 (268)	20200 (541)	21200 (568)
	25	1.7	2400 (64.3)	5200 (139)	10300 (276)	20000 (536)	11800 (316) <sup>(1)</sup>	
	60	4.1	4450 (119)	9000 (241)	12000 (322)	20700 (555)		
	100	6.9	7500 (201)	10000 (268)	13100 (351)			
125	8.6	9500 (255)	10300 (276)					
11 inches w.c. (17 mbar) 655-697-005 ± 2 inches w.c. (5 mbar)	0.5	0.03				800 (21.4)	1500 (40.2)	1600 (42.8)
	1	0.07	400 (10.7)	750 (20.1)	1100 (29.5)	1800 (48.2)	2500 (64.0)	2600 (69.7)
	1.5	0.10	500 (13.4)	1000 (26.8)	1450 (38.9)	2500 (67.0)	3400 (91.1)	3350 (89.8)
	2	0.14	600 (16.1)	1200 (32.2)	1700 (45.6)	3100 (83.1)	3600 (113)	3750 (101)
	5	0.34	1000 (26.8)	2000 (53.6)	3000 (80.4)	7300 (196)	7000 (188)	8500 (228)
	13	0.90	1600 (42.9)	3400 (91.1)	6200 (166)	10350 (277)	17650 (473)	18100 (485)
	25	1.7	2400 (64.3)	5650 (151)	10350 (277)	19300 (517)	23450 (628)	
	60	4.1	4450 (119)	11350 (304)	19300 (517)	20200 (541)		
	100	6.9	7450 (200)	16650 (446)	20200 (541)			
	125	8.6	9500 (255)	17500 (469)				
14 inches w.c. (35 mbar) 655-697-005 ± 2 inches w.c. (5 mbar)	1	0.07	450 (12.1)	700 (18.8)	1100 (29.5)	1500 (40.2)	1700 (45.6)	2700 (72.4)
	1.5	0.10	550 (14.7)	850 (22.8)	1200 (32.3)	1900 (50.9)	2700 (72.4)	3600 (96.5)
	2	0.14	600 (16.1)	1000 (26.8)	1900 (50.9)	2800 (75.0)	3800 (102)	3800 (102)
	5	0.34	1050 (28.1)	1750 (46.9)	2800 (75.0)	4000 (107)	5300 (142)	10600 (284)
	13	0.90	1750 (46.9)	3700 (99.2)	5700 (153)	14400 (386)	18000 (482)	18500 (496)
	25	1.7	2600 (69.7)	5700 (153)	10200 (273)	18000 (482)	25400 (681)	
	60	4.1	4800 (129)	10900 (292)	11000 (295)	19600 (525)		
	100	6.9	7400 (198)	16500 (442)	14100 (378)			
	125	8.6	9100 (244)	18000 (482)				
	20 inches w.c. (50 mbar) 655-697-006 ± 3 inches w.c. (7 mbar)	1	0.07	300 (8.04)	750 (20.1)	550 (14.7)	1250 (33.5)	1700 (45.6)
2		0.14	500 (13.4)	1150 (30.8)	1700 (45.6)	1900 (50.9)	2350 (62.9)	3250 (87.1)
5		0.34	900 (24.1)	1650 (44.2)	2150 (57.6)	3250 (87.1)	6400 (172)	6700 (180)
13		0.90	1500 (40.2)	2550 (68.3)	4350 (117)	5950 (159)	10150 (272)	10500 (281)
25		1.7	2450 (65.7)	4850 (130)	7200 (193)	18100 (485)	19200 (515)	
60		4.1	4900 (131)	9400 (252)	19600 (525)	22700 (608)		
100		6.9	7500 (201)	17400 (466)	13800 (370)			
125		8.6	9150 (245)	5500 (147) <sup>(1)</sup>				

**P200 Flow Capacities in SCFH** (Nm<sup>3</sup>/h) of 0.6 Specific Gravity Natural Gas



Outlet Pressure, Spring Part Number, and Accuracy	Inlet Pressure		NPT 1-1/2 Body Size					
			Orifice Size, Inches (mm)					
	PSIG	BAR	1/4 (6.4)	3/8 (9.5)	1/2 (13)	3/4 (19)	1 (25)	1-3/16 (30)
1 PSIG (0.07 BAR)  655-697-006  ±0.2 PSIG (0.014 BAR)	2	0.14	700 (18.8)	1250 (33.5)	1550 (41.5)	2900 (77.7)	3050 (81.7)	3250 (87.1)
	5	0.34	1050 (28.1)	2150 (57.6)	2800 (75.0)	4800 (129)	5600 (150)	6300 (169)
	10	0.69	1650 (44.2)	3200 (85.8)	4400 (118)	6550 (176)	7800 (209)	8150 (218)
	15	1.0	2000 (53.6)	4100 (110)	5750 (154)	8000 (214)	9400 (252)	10250 (275)
	20	1.4	2300 (61.6)	4750 (127)	6100 (163)	8700 (233)	10950 (293)	
	25	1.7	2600 (69.7)	5500 (147)	8200 (220)	9950 (267)	11550 (310)	
	30	2.1	2900 (77.7)	6250 (168)	8350 (224)	10800 (289)	12250 (328)	
	40	2.8	3600 (96.5)	7500 (201)	9350 (251)	10850 (291)		
	45	3.1	3900 (105)	8400 (225)	10350 (277)	11000 (295)		
	50	3.5	4250 (114)	8900 (239)	10950 (293)	11050 (296)		
	60	4.1	4950 (133)	10000 (268)	11000 (295)	11400 (306)		
	80	5.5	6150 (165)	11150 (299)	11350 (304)			
	100	6.9	7500 (201)	12000 (322)	12000 (322)			
	125	8.6	9150 (245)	12000 (322)				
1 PSIG (0.07 BAR)  655-697-006  ± 1% ABS ±0.16 psia (0.011 BAR)	2	0.14	650 (17.4)	1050 (28.1)	1350 (36.2)	2450 (65.7)	2700 (72.4)	3000 (80.4)
	5	0.34	1050 (28.1)	2100 (56.3)	2700 (72.4)	3800 (102)	4700 (126)	5200 (139)
	10	0.69	1500 (40.2)	2800 (75.0)	3700 (99.2)	5600 (150)	7000 (188)	7300 (196)
	15	1.0	1950 (52.3)	3750 (101)	4900 (131)	6900 (185)	8500 (228)	8750 (235)
	20	1.4	2200 (58.9)	4600 (123)	5800 (155)	8150 (218)	10350 (277)	
	25	1.7	2500 (67.0)	5000 (134)	7250 (194)	9050 (243)	10850 (291)	
	30	2.1	2800 (75.0)	6000 (161)	8200 (220)	9400 (252)	11000 (295)	
	40	2.8	3550 (95.1)	7350 (197)	9100 (244)	9500 (255)		
	45	3.1	3900 (105)	8250 (221)	9650 (259)	10100 (271)		
	50	3.5	4050 (109)	8450 (226)	10300 (276)	10300 (276)		
	60	4.1	4800 (129)	9050 (243)	10450 (280)	10550 (283)		
	80	5.5	5900 (158)	11000 (295)	11100 (297)			
	100	6.9	7400 (198)	11150 (299)	11500 (299)			
	125	8.6	9000 (241)	11750 (315)				
1 PSIG (0.07 BAR)  655-697-006  ± 2% ABS ±0.31 psia (0.021 BAR)	2	0.14	750 (20.1)	1450 (38.9)	2100 (56.3)	3700 (99.2)	4650 (125)	5350 (143)
	5	0.34	1250 (33.5)	2500 (67.0)	3550 (95.1)	6050 (162)	7900 (212)	7900 (212)
	10	0.69	1750 (46.9)	3450 (92.5)	5100 (137)	8550 (229)	9550 (256)	10100 (271)
	15	1.0	2050 (54.9)	4350 (117)	6700 (180)	9400 (252)	11250 (302)	11400 (306)
	20	1.4	2500 (67.0)	5150 (138)	8100 (217)	10500 (281)	12200 (327)	
	25	1.7	2700 (72.4)	5800 (155)	10100 (271)	11550 (310)	12600 (338)	
	30	2.1	3050 (81.7)	6650 (178)	10550 (283)	12350 (331)	13100 (351)	
	40	2.8	3700 (99.2)	7950 (212)	10550 (283)	12350 (331)		
	45	3.1	4100 (110)	8800 (236)	11800 (316)	12700 (340)		
	50	3.5	4550 (122)	9250 (248)	12000 (322)	13000 (348)		
	60	4.1	5000 (134)	10900 (292)	12600 (338)	13000 (348)		
	80	5.5	6450 (173)	12550 (336)	13000 (348)			
	100	6.9	7950 (213)	12900 (346)	13450 (360)			
	125	8.6	9450 (253)	13450 (360)				
1 PSIG (0.07 BAR)  655-697-006  ±0.2 PSIG (0.014 BAR)	2	0.14	500 (13.4)	750 (20.1)	1750 (46.9)	2250 (60.3)	2400 (64.3)	2850 (76.4)
	5	0.34	1100 (29.5)	1800 (48.2)	2300 (61.6)	3400 (91.1)	4850 (130)	5350 (143)
	10	0.69	1600 (42.9)	3200 (85.8)	4600 (123)	7250 (194)	8800 (236)	8800 (236)
	30	2.1	2800 (75.0)	6300 (169)	7800 (209)	10400 (279)	11250 (302)	
	60	4.1	4900 (131)	9600 (257)	9650 (259)	11000 (295)		
	100	6.9	7300 (196)	11200 (300)	11950 (320)			
	125	8.6	9100 (244)	10550 (283) <sup>(1)</sup>				

1. Limited due to boost

- Shaded areas show where maximum operating inlet pressure for a given port diameter is exceeded.

## P200 Flow Capacities in SCFH (Nm<sup>3</sup>/h) of 0.6 Specific Gravity Natural Gas

Outlet Pressure, Spring Part Number, and Accuracy	Inlet Pressure		NPT 2 (DN 50) Body Size					
			Orifice Size, Inches (mm)					
	PSIG	BAR	1/4 (6.4)	3/8 (9.5)	1/2 (13)	3/4 (19)	1 (25)	1-3/16 (30)
1 PSIG (0.07 BAR) 655-697-006  ±0.2 PSIG (0.014 BAR)	2	0.14	650 (17.4)	1200 (32.2)	2200 (58.9)	3200 (85.8)	3600 (96.5)	4500 (121)
	5	0.34	1100 (25.5)	2300 (61.6)	3200 (85.8)	4800 (129)	7700 (206)	10000 (268)
	10	0.69	1600 (42.9)	3000 (80.4)	4300 (115)	11400 (306)	15200 (407)	16300 (437)
	15	1.0	1900 (50.9)	4000 (107)	6900 (185)	15600 (418)	20800 (557)	22300 (598)
	20	1.4	2300 (61.6)	4900 (131)	9100 (244)	19000 (509)	24000 (643)	
	25	1.7	2600 (69.7)	5600 (150)	10500 (281)	21700 (582)	27400 (734)	
	30	2.1	2900 (77.7)	6500 (174)	11800 (316)	25300 (678)	32800 (879)	
	40	2.8	3700 (99.2)	8000 (214)	14500 (389)	27000 (724)		
	45	3.1	4000 (107)	8800 (236)	15800 (423)	27000 (724)		
	50	3.5	4300 (115)	9300 (249)	16600 (445)	28000 (750)		
	60	4.1	4900 (131)	11300 (303)	19500 (523)	31600 (847)		
	80	5.5	6300 (169)	14200 (381)	24000 (643)			
	100	6.9	7700 (206)	16700 (448)	29500 (791)			
	125	8.6	9600 (257)	20200 (541)				
1 PSIG (0.07 BAR) 655-697-006  ± 1% ABS ±0.16 psia (0.011 BAR)	2	0.14	570 (15.3)	1100 (29.5)	2000 (53.6)	2750 (73.7)	3100 (83.1)	4000 (107)
	5	0.34	1050 (28.1)	2200 (58.9)	2750 (73.7)	4100 (110)	6250 (168)	9000 (241)
	10	0.69	1500 (40.2)	2500 (67.0)	4050 (109)	8500 (228)	13250 (355)	13700 (367)
	15	1.0	1900 (50.9)	3450 (92.5)	5800 (155)	15500 (415)	16000 (429)	16300 (437)
	20	1.4	2300 (61.6)	4800 (129)	7700 (206)	18300 (490)	20850 (559)	
	25	1.7	2500 (67.0)	5600 (150)	10400 (279)	21500 (576)	22800 (611)	
	30	2.1	2900 (77.7)	6350 (170)	11950 (320)	23800 (638)	24300 (651)	
	40	2.8	3650 (97.8)	7850 (210)	14550 (390)	24300 (651)		
	45	3.1	3850 (103)	8400 (225)	15600 (418)	25400 (681)		
	50	3.5	4250 (114)	9350 (251)	16700 (448)	26000 (697)		
	60	4.1	4900 (131)	11200 (300)	19400 (520)	32000 (858)		
	80	5.5	6200 (166)	14250 (382)	24600 (659)			
	100	6.9	7400 (198)	16750 (449)	29000 (777)			
	125	8.6	9350 (251)	20200 (541)				
1 PSIG (0.07 BAR) 655-697-006  ± 2% ABS ±0.31 psia (0.021 BAR)	2	0.14	700 (18.8)	1450 (38.9)	2450 (65.7)	4100 (110)	5600 (150)	7900 (212)
	5	0.34	1150 (30.8)	2550 (68.3)	4000 (107)	8000 (214)	11700 (314)	14300 (383)
	10	0.69	1800 (48.2)	3550 (95.1)	6200 (166)	12300 (330)	18400 (493)	20000 (536)
	15	1.0	2050 (54.9)	4450 (119)	7850 (210)	15900 (426)	22000 (590)	24600 (659)
	20	1.4	2400 (64.3)	5250 (141)	9100 (244)	19200 (515)	25800 (691)	
	25	1.7	2750 (73.7)	5900 (158)	10300 (276)	21800 (584)	31200 (836)	
	30	2.1	3150 (84.4)	6550 (176)	11800 (316)	26200 (702)	35000 (938)	
	40	2.8	3750 (101)	8200 (220)	14300 (383)	30500 (817)		
	45	3.1	4050 (109)	8800 (236)	15600 (418)	28100 (753)		
	50	3.5	4400 (118)	9300 (249)	16700 (448)	33900 (909)		
	60	4.1	5050 (135)	10850 (291)	19500 (523)	34200 (917)		
	80	5.5	6350 (170)	13600 (364)	24600 (659)			
	100	6.9	7850 (210)	17000 (456)	30200 (809)			
	125	8.6	9400 (252)	20500 (549)				
1 PSIG (0.07 BAR) 655-697-006  ±0.2 PSIG (0.014 BAR)	2	0.14	500 (13.4)	1050 (28.1)	1400 (37.5)	2200 (58.9)	2900 (77.7)	3700 (99.2)
	5	0.34	1100 (29.5)	2000 (53.6)	2200 (58.9)	4500 (121)	6600 (177)	7000 (188)
	10	0.69	1600 (42.9)	3500 (93.8)	5700 (153)	9700 (260)	13000 (348)	13300 (356)
	30	2.1	2800 (75.0)	6200 (166)	11700 (314)	20000 (536)	23000 (616)	
	60	4.1	4900 (131)	10900 (292)	19300 (517)	20600 (552)		
	100	6.9	7500 (201)	17300 (464)	23900 (641)			
	125	8.6	9000 (241)	19900 (533)				

1. Limited due to boost

 - Shaded areas show where maximum operating inlet pressure for a given port diameter is exceeded.

**P200 H Flow Capacities in SCFH** (Nm<sup>3</sup>/h) of 0.6 Specific Gravity Natural Gas



Outlet Pressure, Spring Part Number, and Accuracy	Inlet Pressure		NPT 1-1/2 Body Size					
			Orifice Size, Inches (mm)					
	PSIG	BAR	1/4 (6.4)	3/8 (9.5)	1/2 (13)	3/4 (19)	1 (25)	1-3/16 (30)
2 PSIG (0.14 BAR) 655-697-007 ±0.2 PSIG (0.014 BAR)	5	0.34	850 (22.8)	1600 (42.9)	1650 (44.2)	2400 (64.3)	2450 (65.7)	3900 (105)
	10	0.69	1450 (38.9)	2050 (54.9)	3250 (87.1)	5400 (145)	5750 (154)	6650 (178)
	15	1.0	1650 (44.2)	3000 (80.4)	4300 (115)	7000 (188)	8200 (220)	8200 (220)
	20	1.4	2050 (54.9)	3850 (103)	5650 (151)	7500 (201)	9050 (243)	
	25	1.7	2500 (67.0)	4600 (123)	6500 (174)	9600 (257)	9700 (260)	
	30	2.1	2750 (73.7)	5650 (151)	6500 (174)	9600 (257)	10850 (291)	
	40	2.8	3500 (93.8)	7000 (188)	8400 (225)	10150 (272)		
	45	3.1	3750 (101)	7800 (209)	9150 (245)	10500 (281)		
	50	3.5	4250 (114)	8500 (228)	9600 (257)	10500 (281)		
	60	4.1	4850 (130)	8800 (236)	9700 (260)	11400 (306)		
	80	5.5	6150 (165)	10000 (268)	11250 (302)			
	100	6.9	7600 (204)	10800 (289)	11250 (302)			
	125	8.6	9300 (249)	12200 (327)				
2 PSIG (0.14 BAR) 655-697-007 ± 1% ABS ±0.04 psia (0.028 BAR)	5	0.34	1100 (29.5)	2200 (58.9)	2800 (75.0)	4550 (122)	5600 (150)	6550 (176)
	10	0.69	1750 (46.9)	3150 (84.4)	4600 (123)	7550 (202)	9050 (243)	10150 (272)
	15	1.0	2000 (53.6)	4200 (113)	6400 (172)	10050 (269)	11000 (295)	11200 (300)
	20	1.4	2400 (64.3)	5000 (134)	7550 (202)	11700 (314)	12200 (327)	
	25	1.7	2700 (72.4)	5750 (154)	9600 (257)	11900 (319)	12950 (347)	
	30	2.1	3100 (83.1)	6700 (180)	9600 (257)	11900 (319)	13300 (356)	
	40	2.8	3750 (101)	7950 (213)	10750 (288)	13000 (348)		
	45	3.1	4100 (110)	8750 (235)	10750 (288)	13000 (348)		
	50	3.5	4550 (122)	9550 (256)	12700 (340)	13000 (348)		
	60	4.1	5150 (138)	11250 (302)	13300 (356)	14400 (386)		
	80	5.5	6450 (173)	12750 (342)	13300 (356)			
	100	6.9	7750 (208)	14450 (387)	13300 (356)			
	125	8.6	9400 (252)	14600 (391)				
2 PSIG (0.14 BAR) 655-697-007 ± 1% ABS ±0.17 psia (0.012 BAR)	5	0.34	850 (22.8)	1400 (37.5)	1450 (38.9)	2250 (60.3)	2450 (65.7)	3300 (88.4)
	10	0.69	1400 (37.5)	1650 (44.2)	2550 (68.3)	4350 (117)	5250 (141)	5600 (150)
	15	1.0	1500 (40.2)	2700 (72.4)	3800 (102)	6000 (161)	5400 (145)	8000 (214)
	20	1.4	2000 (53.6)	3600 (96.5)	5200 (139)	7200 (193)	8200 (220)	
	25	1.7	2400 (64.3)	4500 (121)	6400 (172)	9000 (241)	9550 (256)	
	30	2.1	2800 (75.0)	5600 (150)	7500 (201)	10000 (268)	10400 (279)	
	40	2.8	3600 (96.5)	7800 (209)	9200 (247)	10150 (272)		
	45	3.1	3900 (105)	8400 (225)	9800 (263)	10900 (292)		
	50	3.5	4300 (115)	9100 (244)	10300 (276)	10600 (284)		
	60	4.1	5000 (134)	10200 (273)	11400 (306)	11300 (303)		
	80	5.5	6400 (172)	12000 (322)	10300 (276)(1)			
	100	6.9	7900 (212)	13000 (348)	11150 (299)(1)			
	125	8.6	9600 (257)	11950 (320)(1)				
2 PSIG (0.14 BAR) 655-697-007 ± 2% ABS ±0.33 psia (0.023 BAR)	5	0.34	1050 (28.1)	2100 (56.3)	2500 (67.0)	4100 (110)	5200 (139)	6250 (168)
	10	0.69	1650 (44.2)	3050 (81.7)	4200 (113)	6400 (172)	8350 (224)	8850 (237)
	15	1.0	1900 (50.9)	4200 (113)	6200 (166)	8800 (236)	10500 (281)	10750 (288)
	20	1.4	2200 (58.9)	5100 (137)	7600 (204)	10300 (276)	12000 (322)	
	25	1.7	2500 (67.0)	5800 (155)	8700 (233)	11800 (316)	12050 (323)	
	30	2.1	3000 (80.4)	6500 (174)	9600 (257)	12600 (338)	12700 (340)	
	40	2.8	3600 (96.5)	8100 (217)	11500 (308)	12700 (340)		
	45	3.1	3900 (105)	8800 (236)	12000 (322)	12800 (343)		
	50	3.5	4300 (115)	9700 (260)	12600 (338)	12900 (346)		
	60	4.1	5000 (134)	11300 (303)	13600 (364)	13700 (367)		
	80	5.5	6400 (172)	14200 (381)	12650 (339)			
	100	6.9	7900 (212)	15500 (415)	12950 (347)			
	125	8.6	9600 (257)	14200 (381)(1)				

1. Limited due to boost

- Shaded areas show where maximum operating inlet pressure for a given port diameter is exceeded.

## P200 H Flow Capacities in SCFH (Nm<sup>3</sup>/h) of 0.6 Specific Gravity Natural Gas

Outlet Pressure, Spring Part Number, and Accuracy	Inlet Pressure		NPT 2 (DN 50) Body Size					
			Orifice Size, Inches (mm)					
	PSIG	BAR	1/4 (6.4)	3/8 (9.5)	1/2 (13)	3/4 (19)	1 (25)	1-3/16 (30)
2 PSIG (0.14 BAR) 655-697-007  ±0.2 PSIG (0.014 BAR)	5	0.34	850 (22.8)	1800 (48.2)	1800 (48.2)	2950 (79.1)	4250 (114)	5200 (139)
	10	0.69	1350 (36.2)	1900 (50.9)	3000 (80.4)	5200 (139)	6600 (177)	7800 (209)
	15	1.0	1700 (45.6)	2800 (75.0)	3700 (99.2)	6900 (185)	7200 (193)	9500 (255)
	20	1.4	2000 (53.6)	3800 (102)	5300 (142)	9000 (241)	9800 (263)	
	25	1.7	2450 (65.7)	4500 (121)	6800 (182)	12500 (335)	14200 (381)	
	30	2.1	2650 (71.0)	5200 (139)	7500 (201)	16000 (429)	16100 (431)	
	40	2.8	3400 (91.1)	7400 (198)	13200 (354)	21600 (579)		
	45	3.1	3600 (96.1)	8000 (214)	15500 (415)	21600 (579)		
	50	3.5	4000 (107)	8500 (228)	16700 (448)	21900 (587)		
	60	4.1	4600 (123)	10700 (287)	19200 (515)	18800 (504) <sup>(1)</sup>		
	80	5.5	5800 (155)	13100 (351)	24800 (665)			
	100	6.9	7100 (190)	16200 (434)	25600 (686)			
	125	8.6	9000 (241)	19900 (533)				
2 PSIG (0.14 BAR) 655-697-007  ±0.4 PSIG (0.028 BAR)	5	0.34	1100 (29.5)	2250 (60.3)	3200 (85.8)	5500 (147)	7800 (209)	10100 (271)
	10	0.69	1600 (42.9)	3250 (87.1)	5400 (145)	10000 (268)	14100 (378)	15100 (405)
	15	1.0	2000 (53.6)	4150 (111)	7200 (193)	14400 (386)	18600 (498)	22100 (592)
	20	1.4	2300 (61.6)	4950 (133)	9000 (241)	17500 (469)	24000 (643)	
	25	1.7	2650 (71.0)	5800 (155)	10200 (273)	20700 (555)	28000 (750)	
	30	2.1	3100 (83.1)	6600 (177)	11800 (316)	24900 (667)	28500 (764)	
	40	2.8	3600 (96.5)	8100 (217)	14600 (391)	28000 (750)		
	45	3.1	4100 (110)	8850 (237)	15800 (423)	29000 (777)		
	50	3.5	4400 (118)	9850 (264)	17200 (461)	29200 (783)		
	60	4.1	4900 (131)	11300 (303)	19500 (523)	29300 (785)		
	80	5.5	6400 (172)	14300 (383)	24500 (657)			
	100	6.9	7600 (204)	17200 (461)	29700 (796)			
	125	8.6	9400 (252)	20500 (549)				
2 PSIG (0.14 BAR) 655-697-007  ± 1% ABS ±0.17 psia (0.012 BAR)	5	0.34	750 (20.1)	1600 (42.9)	1600 (42.9)	2400 (64.3)	3000 (80.4)	4100 (110)
	10	0.69	1250 (33.5)	1600 (42.9)	2550 (68.3)	4250 (114)	5000 (134)	6100 (163)
	15	1.0	1600 (42.9)	2700 (72.4)	3800 (102)	5200 (139)	6900 (185)	7600 (204)
	20	1.4	2000 (53.6)	3600 (96.5)	5200 (139)	6900 (185)	9400 (252)	
	25	1.7	2450 (65.7)	4400 (118)	7500 (201)	9600 (257)	10650 (285)	
	30	2.1	2800 (75.0)	5200 (139)	8600 (230)	11800 (316)	16100 (431)	
	40	2.8	3700 (99.2)	7500 (201)	12200 (327)	16200 (434)		
	45	3.1	4100 (110)	8400 (225)	15200 (407)	18350 (492)		
	50	3.5	4400 (118)	9000 (241)	16900 (453)	21000 (563)		
	60	4.1	5100 (137)	11000 (295)	20800 (557)	21000 (563)		
	80	5.5	6500 (174)	14600 (391)	24800 (665)			
	100	6.9	8000 (214)	18000 (482)	29300 (785)			
	125	8.6	9800 (263)	20500 (549)				
2 PSIG (0.14 BAR) 655-697-007  ± 2% ABS ±0.33 psia (0.023 BAR)	5	0.34	1000 (26.8)	2150 (57.6)	2750 (73.7)	5000 (134)	6200 (166)	7900 (212)
	10	0.69	1550 (41.5)	3050 (81.7)	5000 (134)	8600 (230)	12750 (342)	13800 (370)
	15	1.0	1900 (50.9)	4200 (113)	7200 (193)	11000 (295)	11750 (315)	21700 (582)
	20	1.4	2300 (61.6)	5100 (137)	9200 (247)	14200 (381)	16000 (429)	
	25	1.7	2600 (69.7)	5900 (158)	10700 (287)	16400 (440)	25400 (681)	
	30	2.1	3000 (80.4)	6600 (177)	12100 (324)	19700 (528)	27900 (748)	
	40	2.8	3700 (99.2)	8200 (220)	12200 (327)	27200 (729)		
	45	3.1	4100 (110)	9000 (241)	15200 (407)	27200 (729)		
	50	3.5	4400 (118)	9700 (260)	16900 (453)	27400 (734)		
	60	4.1	5100 (137)	11300 (303)	20800 (557)	27400 (734)		
	80	5.5	6500 (174)	14600 (391)	24500 (657)			
	100	6.9	8000 (214)	18000 (482)	29600 (793)			
	125	8.6	9800 (263)	20500 (549)				

1. Limited due to boost

 - Shaded areas show where maximum operating inlet pressure for a given port diameter is exceeded.

**P200H Flow Capacities in SCFH** (Nm<sup>3</sup>/h) of 0.6 Specific Gravity Natural Gas



Outlet Pressure, Spring Part Number, and Accuracy	Inlet Pressure		NPT 1-1/2 Body Size					
			Orifice Size, Inches (mm)					
	PSIG	BAR	1/4 (6.4)	3/8 (9.5)	1/2 (13)	3/4 (19)	1 (25)	1-3/16 (30)
3 PSIG (0.21 BAR)  655-697-008  ±0.3 PSIG (0.021 BAR)	5	0.34	800 (21.4)	1350 (36.2)	1650 (44.2)	2500 (67.0)	2500 (67.0)	3850 (103)
	10	0.69	1200 (32.2)	1800 (48.2)	2650 (71.0)	4600 (123)	6050 (162)	6600 (177)
	15	1.0	1650 (44.2)	2300 (61.6)	3750 (101)	5600 (174)	9200 (247)	8200 (220)
	20	1.4	1950 (52.3)	3500 (93.8)	5000 (134)	8350 (224)	9200 (247)	
	25	1.7	2150 (57.6)	4400 (118)	6500 (174)	8150 (218)	10050 (269)	
	30	2.1	2700 (72.4)	5600 (150)	6700 (180)	10050 (269)	11250 (302)	
	40	2.8	3300 (88.4)	6900 (185)	7900 (212)	10300 (275)		
	45	3.1	3550 (95.1)	7000 (188)	8650 (232)	11000 (295)		
	50	3.5	4050 (109)	7800 (209)	9700 (260)	11000 (295)		
	60	4.1	4250 (114)	8200 (220)	9900 (265)	11450 (307)		
	80	5.5	5950 (159)	10000 (268)	11600 (311)			
	100	6.9	7450 (200)	11750 (315)	11900 (319)			
	125	8.6	8800 (236)	12200 (327)				
3 PSIG (0.21 BAR)  655-697-008  ±0.6 PSIG (0.041 BAR)	5	0.34	1100 (29.5)	1950 (52.3)	2800 (75.0)	4250 (114)	5400 (145)	7200 (193)
	10	0.69	1650 (44.2)	3100 (83.1)	4650 (125)	7750 (208)	8700 (233)	9100 (244)
	15	1.0	2050 (54.9)	4100 (110)	5950 (159)	9550 (256)	11150 (299)	11800 (316)
	20	1.4	2400 (64.3)	4900 (131)	7800 (209)	10650 (285)	12350 (331)	
	25	1.7	2600 (69.7)	5750 (154)	8700 (233)	11950 (320)	14050 (377)	
	30	2.1	3100 (83.1)	6550 (176)	10250 (275)	12050 (323)	14400 (386)	
	40	2.8	3150 (84.4)	7850 (210)	11300 (303)	13800 (370)		
	45	3.1	4150 (111)	8400 (225)	12450 (334)	14150 (379)		
	50	3.5	4400 (118)	9300 (249)	12450 (334)	14150 (379)		
	60	4.1	5000 (134)	10700 (287)	13000 (348)	15350 (411)		
	80	5.5	6400 (172)	13050 (350)	16000 (429)			
	100	6.9	7650 (205)	15400 (413)	16050 (430)			
	125	8.6	9200 (247)	16050 (430)				
3 PSIG (0.21 BAR)  655-697-008  ± 1% ABS ±0.18 psia (0.012 BAR)	5	0.34	500 (13.4)	1150 (30.8)	1200 (32.2)	1450 (38.9)	1550 (41.5)	2100 (56.3)
	10	0.69	900 (24.1)	1350 (36.2)	1500 (40.2)	2750 (73.7)	3200 (85.8)	3400 (91.1)
	15	1.0	1200 (32.2)	1700 (45.6)	2200 (58.9)	3900 (105)	4900 (131)	4950 (133)
	20	1.4	1500 (40.2)	2100 (56.3)	2900 (77.7)	5300 (142)	8000 (214)	
	25	1.7	1900 (50.9)	2600 (69.7)	4300 (115)	7400 (198)	9350 (251)	
	30	2.1	2200 (58.9)	3100 (83.1)	5100 (137)	8400 (225)	8650 (232) <sup>(1)</sup>	
	40	2.8	2900 (77.7)	4800 (129)	8000 (214)	8750 (235)		
	45	3.1	3300 (88.4)	5800 (155)	9300 (249)	9900 (265)		
	50	3.5	3700 (99.2)	6800 (182)	10200 (273)	10600 (284)		
	60	4.1	4400 (118)	8400 (225)	11600 (311)	10700 (287)		
	80	5.5	6300 (169)	10800 (289)	9400 (252) <sup>(1)</sup>			
	100	6.9	8100 (217)	12100 (324)	11750 (315)			
	125	8.6	10000 (268)	10750 (288) <sup>(1)</sup>				
3 PSIG (0.21 BAR)  655-697-008  ± 2% ABS ±0.35 psia (0.024 BAR)	5	0.34	900 (24.1)	1450 (38.9)	1800 (48.2)	3000 (80.4)	3000 (80.4)	4650 (125)
	10	0.69	1250 (33.5)	2050 (54.9)	3150 (84.4)	5150 (138)	6450 (173)	6650 (178)
	15	1.0	1800 (48.2)	3100 (83.1)	4400 (118)	7200 (193)	8700 (233)	8700 (233)
	20	1.4	2200 (58.9)	3800 (102)	6100 (163)	8600 (230)	11000 (295)	
	25	1.7	2600 (69.7)	5000 (134)	7600 (204)	9700 (260)	11050 (296)	
	30	2.1	2900 (77.7)	5800 (155)	8700 (233)	11200 (300)	11450 (3070)	
	40	2.8	3600 (96.5)	7800 (209)	10800 (289)	11600 (311)		
	45	3.1	4000 (107)	8400 (225)	11600 (311)	11600 (311)		
	50	3.5	4600 (123)	9400 (252)	12400 (332)	11750 (315)		
	60	4.1	5100 (137)	10600 (284)	13800 (370)	13250 (355)		
	80	5.5	6500 (174)	12700 (340)	12600 (338) <sup>(1)</sup>			
	100	6.9	8100 (217)	14400 (386)	12550 (336) <sup>(1)</sup>			
	125	8.6	10000 (268)	12500 (335) <sup>(1)</sup>				

1. Limited due to boost

- Shaded areas show where maximum operating inlet pressure for a given port diameter is exceeded.

## P200H Flow Capacities in SCFH (Nm<sup>3</sup>/h) of 0.6 Specific Gravity Natural Gas

Outlet Pressure, Spring Part Number, and Accuracy	Inlet Pressure		NPT 2 (DN 50) Body Size					
			Orifice Size, Inches (mm)					
	PSIG	BAR	1/4 (6.4)	3/8 (9.5)	1/2 (13)	3/4 (19)	1 (25)	1-3/16 (30)
3 PSIG (0.21 BAR) 655-697-008  ±0.3 PSIG (0.021 BAR)	5	0.34	750 (20.1)	1400 (37.5)	1600 (42.9)	2400 (64.3)	2900 (77.7)	3500 (93.8)
	10	0.69	1200 (32.2)	1900 (50.9)	2750 (73.7)	5000 (134)	6400 (171)	6900 (185)
	15	1.0	1400 (37.5)	2000 (53.6)	3100 (83.1)	5900 (158)	7700 (206)	9800 (263)
	20	1.4	1850 (49.6)	3000 (80.4)	4150 (111)	7700 (206)	7900 (212)	
	25	1.7	2050 (54.9)	3900 (105)	5000 (134)	9100 (244)	9750 (261)	
	30	2.1	2550 (68.3)	4800 (129)	6700 (180)	10100 (271)	17200 (461)	
	40	2.8	3150 (84.4)	6250 (168)	8700 (233)	11600 (311)		
	45	3.1	3400 (91.1)	6750 (181)	9900 (265)	14500 (389)		
	50	3.5	3900 (105)	6750 (181)	12300 (330)	13900 (373)		
	60	4.1	4350 (117)	9400 (252)	12700 (340)	18300 (490)		
	80	5.5	5600 (150)	12700 (340)	18800 (504)			
	100	6.9	7000 (188)	14800 (397)	18800 (504)			
	125	8.6	8650 (232)	18800 (504)				
3 PSIG (0.21 BAR) 655-697-008  ±0.6 PSIG (0.041 BAR)	5	0.34	1100 (29.5)	1950 (52.3)	2550 (68.3)	4700 (126)	6000 (161)	7450 (200)
	10	0.69	1550 (41.5)	3000 (80.4)	4750 (127)	8600 (230)	12200 (327)	15400 (413)
	15	1.0	2050 (54.9)	3850 (103)	5950 (159)	12500 (338)	16200 (434)	20300 (544)
	20	1.4	2400 (64.3)	4850 (130)	8200 (220)	17000 (456)	21800 (584)	
	25	1.7	2800 (75.0)	5750 (154)	9800 (263)	19700 (528)	23000 (616)	
	30	2.1	3150 (84.4)	6450 (173)	11600 (311)	22500 (603)	26500 (710)	
	40	2.8	3650 (97.8)	7850 (210)	14300 (383)	26400 (708)		
	45	3.1	4100 (110)	8900 (239)	15500 (415)	28500 (764)		
	50	3.5	4350 (117)	9450 (253)	17000 (456)	29600 (793)		
	60	4.1	5100 (137)	11100 (297)	19850 (532)	29900 (801)		
	80	5.5	6350 (170)	14350 (385)	25200 (675)			
	100	6.9	7250 (194)	17250 (462)	29400 (788)			
	125	8.6	9400 (252)	21000 (563)				
3 PSIG (0.21 BAR) 655-697-008  ± 1% ABS ±0.18 psia (0.012 BAR)	5	0.34	650 (17.4)	1100 (29.3)	790 (21.2)	1500 (40.2)	1700 (45.6)	1750 (46.9)
	10	0.69	1000 (26.8)	1250 (33.5)	1500 (40.2)	2500 (67.0)	3700 (99.2)	4300 (115)
	15	1.0	1250 (33.5)	1750 (46.9)	2000 (53.6)	2900 (77.7)	3750 (101)	6000 (161)
	20	1.4	1450 (38.9)	2400 (64.3)	2200 (58.9)	4100 (110)	5750 (154)	
	25	1.7	1600 (42.8)	2900 (77.7)	4000 (107)	6900 (185)	6400 (172)	
	30	2.1	1950 (52.3)	3550 (95.1)	4400 (118)	8700 (233)	6700 (180)	
	40	2.8	2700 (72.4)	3850 (103)	5500 (147)	6450 (173)		
	45	3.1	2900 (77.7)	5400 (145)	9000 (241)	8000 (214)		
	50	3.5	3300 (88.4)	5700 (153)	9100 (244)	7900 (212)		
	60	4.1	3900 (105)	7200 (193)	11500 (308)	10300 (276)		
	80	5.5	5250 (141)	9200 (247)	9800 (263) <sup>(1)</sup>			
	100	6.9	6250 (168)	11300 (303)	10900 (292) <sup>(1)</sup>			
	125	8.6	7750 (208)	12650 (339)				
3 PSIG (0.21 BAR) 655-697-008  ± 2% ABS ±0.35 psia (0.024 BAR)	5	0.34	800 (21.4)	1450 (38.9)	1700 (45.6)	3150 (84.4)	3250 (87.1)	4000 (107)
	10	0.69	1300 (34.8)	2150 (57.6)	3200 (85.8)	5550 (149)	7200 (193)	9000 (241)
	15	1.0	1550 (41.5)	2850 (76.4)	4050 (109)	6800 (182)	8250 (221)	10800 (289)
	20	1.4	1850 (49.6)	3300 (88.4)	5400 (145)	9300 (249)	10900 (292)	
	25	1.7	2350 (62.9)	4650 (125)	6700 (180)	11250 (302)	15600 (418)	
	30	2.1	2450 (65.7)	5100 (137)	8600 (230)	12250 (328)	17350 (465)	
	40	2.8	3150 (84.4)	6950 (186)	11400 (306)	15150 (406)		
	45	3.1	3400 (91.1)	7650 (205)	11900 (319)	18150 (486)		
	50	3.5	3800 (102)	8500 (228)	14000 (375)	20200 (541)		
	60	4.1	4300 (115)	9850 (264)	19000 (509)	21150 (567)		
	80	5.5	5500 (147)	12600 (338)	23100 (619)			
	100	6.9	6500 (174)	15500 (415)	23650 (634)			
	125	8.6	8100 (217)	20650 (553)				

1. Limited due to boost

 - Shaded areas show where maximum operating inlet pressure for a given port diameter is exceeded.

**P200H Flow Capacities in SCFH** (Nm<sup>3</sup>/h) of 0.6 Specific Gravity Natural Gas



Outlet Pressure, Spring Part Number, and Accuracy	Inlet Pressure		NPT 1-1/2 Body Size					
			Orifice Size, Inches (mm)					
	PSIG	BAR	1/4 (6.4)	3/8 (9.5)	1/2 (13)	3/4 (19)	1 (25)	1-3/16 (30)
5 PSIG (0.34 BAR) 655-697-009 ±0.5 PSIG (0.034 BAR)	10	0.69	1200 (32.2)	1850 (49.6)	2300 (61.6)	3350 (89.8)	4750 (127)	5500 (147)
	15	1.0	1350 (36.2)	2450 (65.7)	3200 (85.8)	5350 (141)	6650 (178)	7550 (202)
	20	1.4	1850 (49.6)	3200 (85.8)	3900 (105)	6700 (180)	8600 (230)	
	25	1.7	2200 (58.9)	3600 (96.5)	4900 (131)	8250 (221)	10000 (268)	
	30	2.1	2500 (67.0)	5100 (137)	6500 (174)	8800 (236)	11450 (307)	
	40	2.8	3250 (87.1)	6100 (163)	7650 (205)	10650 (285)		
	45	3.1	3650 (97.8)	6950 (186)	8500 (228)	11200 (300)		
	50	3.5	3850 (103)	7550 (202)	9250 (248)	12250 (328)		
	60	4.1	4600 (123)	8550 (229)	10300 (276)	12950 (347)		
	80	5.5	5900 (158)	10550 (283)	12500 (335)			
	100	6.9	7250 (194)	12000 (322)	12550 (336)			
	125	8.6	9000 (241)	13300 (356)				
5 PSIG (0.34 BAR) 655-697-009 ±1 PSIG (0.69 BAR)	10	0.69	1550 (41.5)	2850 (76.4)	4050 (109)	6450 (173)	8450 (226)	9800 (263)
	15	1.0	2000 (53.6)	3850 (103)	5800 (155)	9250 (248)	11150 (299)	12400 (332)
	20	1.4	2450 (65.7)	4750 (127)	7150 (192)	11400 (306)	13250 (355)	
	25	1.7	2800 (75.0)	5700 (153)	8600 (230)	12800 (343)	15250 (409)	
	30	2.1	3100 (83.1)	6400 (172)	10050 (269)	13550 (363)	16800 (450)	
	40	2.8	3700 (99.2)	7850 (210)	12350 (331)	15650 (419)		
	45	3.1	4050 (109)	8600 (230)	13000 (348)	15950 (427)		
	50	3.5	4450 (119)	9400 (252)	13650 (366)	16300 (437)		
	60	4.1	5050 (135)	10700 (287)	15100 (405)	18200 (488)		
	80	5.5	6300 (169)	13400 (359)	17650 (473)			
	100	6.9	7600 (204)	15950 (427)	17650 (473)			
	125	8.6	9200 (247)	17800 (477)				
5 PSIG (0.34 BAR) 655-697-009 ± 1% ABS ±0.20 psia (0.014 BAR)	10	0.69	650 (17.4)	900 (24.1)	1050 (28.1)	1200 (32.2)	1950 (52.3)	2200 (58.9)
	15	1.0	800 (21.4)	1100 (29.5)	1500 (40.2)	2000 (53.6)	2600 (69.7)	3400 (91.1)
	20	1.4	1050 (28.1)	1400 (37.5)	2050 (54.9)	2800 (75.0)	3800 (102)	
	25	1.7	1200 (32.2)	1800 (48.2)	2350 (62.9)	3800 (102)	4400 (118)	
	30	2.1	1450 (38.9)	2200 (58.9)	3000 (80.4)	4900 (131)	5250 (141)	
	40	2.8	1950 (52.3)	2950 (79.1)	4400 (118)	5750 (154)		
	45	3.1	2200 (58.9)	3300 (88.4)	5000 (134)	6550 (176)		
	50	3.5	2400 (64.3)	3850 (103)	6200 (166)	8200 (220)		
	60	4.1	2950 (79.1)	4800 (129)	8400 (225)	9250 (248)		
	80	5.5	4000 (107)	7400 (198)	7800 (209)			
	100	6.9	5300 (142)	10700 (287)	9200 (247)			
	125	8.6	7200 (193)	6150 (165) <sup>(1)</sup>				
5 PSIG (0.34 BAR) 655-697-009 ± 2% ABS ±0.39 psia (0.028 BAR)	10	0.69	1050 (28.1)	1650 (44.2)	1950 (52.3)	2600 (69.7)	3700 (99.2)	4900 (131)
	15	1.0	1350 (36.2)	2050 (54.9)	2900 (77.7)	4300 (115)	5600 (150)	6350 (170)
	20	1.4	1750 (46.9)	2700 (72.4)	3900 (105)	5800 (155)	7400 (198)	
	25	1.7	2100 (56.3)	3350 (89.8)	4850 (130)	7300 (196)	8750 (235)	
	30	2.1	2400 (64.3)	4050 (109)	5750 (154)	8700 (233)	10150 (272)	
	40	2.8	3200 (85.8)	5300 (142)	8000 (214)	9800 (263)		
	45	3.1	3500 (93.8)	6050 (162)	8950 (240)	10750 (288)		
	50	3.5	3900 (105)	6800 (182)	9800 (263)	11000 (295)		
	60	4.1	4700 (126)	8400 (225)	11500 (308)	12100 (324)		
	80	5.5	6150 (165)	11100 (297)	10300 (276) <sup>(1)</sup>			
	100	6.9	7900 (212)	13100 (351)	11200 (300) <sup>(1)</sup>			
	125	8.6	9700 (260)	11950 (320) <sup>(1)</sup>				

1. Limited due to boost

- Shaded areas show where maximum operating inlet pressure for a given port diameter is exceeded.

## P200H Flow Capacities in SCFH (Nm<sup>3</sup>/h) of 0.6 Specific Gravity Natural Gas

Outlet Pressure, Spring Part Number, and Accuracy	Inlet Pressure		NPT 2 (DN 50) Body Size					
			Orifice Size, Inches (mm)					
	PSIG	BAR	1/4 (6.4)	3/8 (9.5)	1/2 (13)	3/4 (19)	1 (25)	1-3/16 (30)
5 PSIG (0.34 BAR) 655-697-009 ±0.5 PSIG (0.034 BAR)	10	0.69	1200 (32.2)	1700 (45.6)	2200 (58.9)	3750 (101)	5300 (142)	5800 (155)
	15	1.0	1400 (37.5)	2100 (56.3)	2850 (76.4)	5500 (147)	6850 (184)	8150 (218)
	20	1.4	1800 (48.2)	2850 (76.4)	3750 (101)	7000 (188)	7700 (206)	
	25	1.7	2050 (54.9)	3750 (101)	4550 (122)	7900 (212)	9750 (261)	
	30	2.1	2500 (67.0)	4550 (122)	5800 (155)	8500 (228)	10750 (288)	
	40	2.8	3150 (84.4)	5800 (155)	6200 (166)	12000 (322)		
	45	3.1	3500 (93.8)	6200 (166)	7000 (188)	12850 (344)		
	50	3.5	3900 (105)	7000 (188)	7700 (206)	14200 (381)		
	60	4.1	4350 (117)	7700 (206)	10950 (293)	16650 (446)		
	80	5.5	5850 (157)	10950 (293)	13500 (362)			
	100	6.9	7150 (192)	13500 (362)	16400 (440)			
	125	8.6	8900 (239)	16400 (440)				
5 PSIG (0.34 BAR) 655-697-009 ±1 PSIG (0.69 BAR)	10	0.69	1500 (40.2)	2800 (75.0)	4050 (109)	7350 (197)	9400 (252)	12400 (332)
	15	1.0	2050 (54.9)	3950 (106)	5700 (153)	10750 (288)	12950 (347)	17100 (458)
	20	1.4	2400 (64.3)	4750 (127)	7300 (196)	13550 (363)	18450 (494)	
	25	1.7	2750 (73.7)	5450 (146)	9100 (244)	16200 (434)	20400 (547)	
	30	2.1	3100 (83.1)	6500 (174)	10500 (281)	19200 (515)	24700 (662)	
	40	2.8	3750 (101)	7850 (210)	13700 (367)	25250 (677)		
	45	3.1	4050 (109)	8550 (229)	15150 (406)	25700 (689)		
	50	3.5	4400 (118)	9600 (257)	16650 (446)	27950 (749)		
	60	4.1	4950 (133)	10850 (291)	19150 (513)	30550 (819)		
	80	5.5	6450 (173)	14000 (375)	24150 (647)			
	100	6.9	7700 (206)	17000 (456)	29400 (788)			
	125	8.6	9250 (248)	20700 (555)				
5 PSIG (0.34 BAR) 655-697-009 ± 1% ABS ±0.20 psia (0.014 BAR)	10	0.69	500 (13.4)	850 (22.8)	1000 (26.8)	1500 (40.2)	2000 (53.6)	2200 (58.9)
	15	1.0	750 (20.1)	1200 (32.2)	1400 (37.5)	1900 (50.9)	2300 (61.6)	2900 (77.7)
	20	1.4	1000 (26.8)	1550 (41.5)	1900 (50.9)	2700 (72.4)	3000 (80.4)	
	25	1.7	1250 (33.5)	1950 (52.3)	2300 (61.6)	3400 (91.1)	3700 (99.2)	
	30	2.1	1450 (38.9)	2200 (58.9)	2800 (75.0)	4100 (110)	4000 (107)	
	40	2.8	1900 (50.9)	3100 (83.1)	4000 (107)	3300 (88.4)		
	45	3.1	2100 (56.3)	3400 (91.1)	4400 (118)	4600 (123)		
	50	3.5	2400 (64.3)	3800 (102)	5000 (134)	5300 (142)		
	60	4.1	2800 (75.0)	4700 (126)	6600 (177)	7250 (194)		
	80	5.5	3900 (105)	7300 (196)	5050 (135) <sup>(1)</sup>			
	100	6.9	5000 (134)	9300 (249)	6400 (172) <sup>(1)</sup>			
	125	8.6	7000 (188)	6000 (161) <sup>(1)</sup>				
5 PSIG (0.34 BAR) 655-697-009 ± 2% ABS ±0.39 psia (0.028 BAR)	10	0.69	1000 (26.8)	1400 (37.5)	1650 (44.2)	2900 (77.7)	3500 (93.8)	4500 (121)
	15	1.0	1300 (34.8)	2100 (56.3)	2800 (75.0)	3900 (105)	5500 (147)	5850 (157)
	20	1.4	1650 (44.2)	2750 (73.7)	3600 (96.5)	5300 (142)	7400 (198)	
	25	1.7	2050 (54.9)	3400 (91.1)	4400 (118)	6800 (182)	7400 (196)	
	30	2.1	2400 (64.3)	4000 (107)	5500 (147)	7900 (212)	8350 (224)	
	40	2.8	3100 (83.1)	5400 (145)	7200 (193)	9300 (249)		
	45	3.1	3250 (87.1)	6100 (163)	8300 (222)	9850 (264)		
	50	3.5	3850 (103)	6700 (180)	9400 (252)	10650 (285)		
	60	4.1	4450 (119)	8200 (220)	11500 (308)	14550 (390)		
	80	5.5	6100 (163)	11000 (295)	10850 (291) <sup>(1)</sup>			
	100	6.9	7600 (204)	14000 (375)	11800 (316)			
	125	8.6	9600 (257)	11650 (312) <sup>(1)</sup>				

1. Limited due to boost

 - Shaded areas show where maximum operating inlet pressure for a given port diameter is exceeded.

**P200 K Flow Capacities in SCFH (Nm<sup>3</sup>/h) of 0.6 Specific Gravity Natural Gas**



Outlet Pressure, Spring Part Number, and Accuracy	Inlet Pressure		NPT 1-1/2 & 2 (DN 50) Body Size					
			Orifice Size, Inches (mm)					
	PSIG	BAR	1/4 (6.4)	3/8 (9.5)	1/2 (13)	3/4 (19)	1 (25)	1-3/16 (30)
5 PSIG (0.34 BAR)  655-659-003  ±0.5 PSIG (0.034 BAR)	10	0.69	500 (13.4)	1000 (26.8)	1250 (33.5)	1900 (50.9)	2150 (57.6)	2550 (68.3)
	15	1.0	550 (14.7)	1300 (34.8)	1650 (44.2)	2650 (71.0)	3200 (85.8)	4000 (107)
	20	1.4	600 (16.1)	1650 (44.2)	1950 (52.3)	3300 (88.4)	4100 (110)	5000 (134)
	25	1.7	800 (21.4)	1950 (52.3)	2150 (57.6)	3950 (106)	4650 (125)	
	30	2.1	1600 (42.9)	2150 (57.6)	2650 (71.0)	4500 (121)	5500 (147)	
	40	2.8	1950 (52.3)	2650 (71.0)	2900 (77.7)	5800 (155)		
	45	3.1	2250 (60.3)	2900 (77.7)	3450 (92.5)	6200 (166)		
	50	3.5	2450 (65.7)	3450 (92.5)	3800 (102)	6600 (177)		
	60	4.1	2600 (69.7)	3800 (102)	5350 (143)	8700 (233)		
	80	5.5	3700 (99.2)	5350 (143)	5900 (158)			
	100	6.9	4100 (110)	5900 (158)	7950 (213)			
	125	8.6	5450 (146)	7950 (213)				
5 PSIG (0.34 BAR)  655-659-003  ±1 PSIG (0.69 BAR)	10	0.69	1150 (30.8)	1700 (45.6)	2250 (60.3)	3400 (91.1)	4550 (122)	5650 (151)
	15	1.0	1300 (34.8)	2550 (68.3)	3150 (84.4)	5200 (139)	6350 (170)	8100 (217)
	20	1.4	1900 (50.9)	2950 (79.1)	3950 (106)	6000 (161)	8300 (222)	9950 (267)
	25	1.7	2200 (58.9)	3650 (97.8)	4850 (130)	7050 (189)	9950 (267)	
	30	2.1	2650 (71.0)	4000 (107)	5500 (147)	8750 (235)	11750 (315)	
	40	2.8	3100 (83.1)	5000 (134)	6900 (185)	10850 (291)		
	45	3.1	3450 (92.5)	5800 (155)	7650 (205)	11700 (314)		
	50	3.5	3800 (102)	6450 (173)	8900 (239)	14100 (378)		
	60	4.1	4400 (118)	7450 (200)	9800 (263)	14900 (399)		
	80	5.5	5950 (159)	9300 (249)	12000 (322)			
	100	6.9	7000 (188)	11250 (302)	14750 (395)			
	125	8.6	8450 (226)	13800 (370)				
5 PSIG (0.34 BAR)  655-659-003  ± 1% ABS ±0.20 psia (0.014 BAR)	10	0.69	350 (9.38)	400 (10.7)	650 (17.4)	800 (21.4)	1050 (28.1)	1300 (34.8)
	15	1.0	350 (9.38)	750 (20.1)	850 (22.8)	1250 (33.5)	1550 (41.5)	1650 (44.2)
	20	1.4	500 (13.4)	900 (24.1)	1050 (28.1)	1650 (44.2)	1800 (48.2)	2050 (54.9)
	25	1.7	600 (16.1)	1000 (26.8)	1200 (32.2)	1650 (44.2)	1950 (52.3)	
	30	2.1	700 (18.8)	1100 (29.5)	1300 (34.8)	1950 (52.3)	2550 (68.3)	
	40	2.8	1000 (26.8)	1350 (36.2)	1350 (36.2)	2450 (65.7)		
	45	3.1	1100 (29.5)	1450 (38.9)	1550 (41.5)	2550 (68.3)		
	50	3.5	1150 (30.8)	1600 (43.9)	1600 (42.9)	3050 (81.7)		
	60	4.1	1150 (30.8)	1750 (46.9)	2250 (60.3)	2400 (64.3) <sup>(1)</sup>		
	80	5.5	1600 (42.9)	2350 (62.9)	2750 (73.7)			
	100	6.9	1650 (44.2)	2400 (64.3)	3250 (87.1)			
	125	8.6	2150 (57.6)	3050 (81.7)				
5 PSIG (0.34 BAR)  655-659-003  ± 2% ABS ±0.39 psia (0.028 BAR)	10	0.69	450 (12.1)	450 (12.1)	1100 (29.5)	1500 (40.2)	1700 (45.6)	2250 (60.3)
	15	1.0	450 (12.1)	1150 (30.8)	1500 (40.2)	2150 (57.6)	2500 (67.0)	3300 (88.4)
	20	1.4	550 (14.7)	1400 (37.5)	1700 (45.6)	2800 (75.0)	3350 (89.8)	3900 (105)
	25	1.7	1250 (33.5)	1650 (44.2)	2050 (54.9)	3050 (81.7)	4200 (113)	
	30	2.1	1350 (36.2)	1850 (49.6)	2500 (67.0)	3750 (101)	4350 (117)	
	40	2.8	1700 (45.6)	2200 (58.9)	2900 (77.7)	4700 (126)		
	45	3.1	1800 (48.2)	2350 (62.9)	3500 (93.8)	5200 (139)		
	50	3.5	1900 (50.9)	2850 (76.4)	3950 (103)	5900 (158)		
	60	4.1	2100 (56.3)	2900 (77.7)	4300 (115)	6900 (185)		
	80	5.5	3100 (83.1)	4050 (109)	5500 (147)			
	100	6.9	3400 (91.1)	4800 (129)	6050 (162)			
	125	8.6	4400 (118)	5750 (154)				

1. Limited due to boost

- Shaded areas show where maximum operating inlet pressure for a given port diameter is exceeded.

## P200 K Flow Capacities in SCFH (Nm<sup>3</sup>/h) of 0.6 Specific Gravity Natural Gas

Outlet Pressure, Spring Part Number, and Accuracy	Inlet Pressure		NPT 1-1/2 & 2 (DN 50) Body Size					
			Orifice Size, Inches (mm)					
	PSIG	BAR	1/4 (6.4)	3/8 (9.5)	1/2 (13)	3/4 (19)	1 (25)	1-3/16 (30)
10 PSIG (0.69 BAR)  655-697-010  ±1 PSIG (0.69 BAR)	10	0.69	550 (14.7)	800 (21.4)	1050 (28.1)	1200 (32.2)	1350 (36.2)	1750 (46.9)
	15	1.0	700 (18.8)	1200 (32.2)	1650 (44.2)	2500 (67.0)	2950 (79.1)	3800 (102)
	20	1.4	800 (21.4)	1650 (44.2)	2100 (56.3)	3150 (84.4)	4450 (119)	5350 (143)
	25	1.7	1500 (40.2)	2000 (53.6)	2750 (73.7)	4350 (117)	4900 (131)	6500 (174)
	30	2.1	1850 (49.6)	2300 (61.6)	3000 (80.4)	4850 (130)	6200 (166)	
	40	2.8	2150 (57.6)	3050 (81.7)	4100 (110)	6400 (172)		
	45	3.1	2300 (61.6)	3400 (91.1)	4600 (123)	7150 (192)		
	50	3.5	2500 (67.0)	3950 (106)	5100 (137)	7650 (205)		
	60	4.1	2900 (77.7)	4350 (117)	6000 (161)	8550 (229)		
	80	5.5	3900 (105)	5950 (159)	7550 (202)			
	100	6.9	4650 (125)	6800 (182)	9650 (259)			
	125	8.6	5300 (142)	8200 (220)				
10 PSIG (0.69 BAR)  655-697-010  ±2 PSIG (0.14 BAR)	10	0.69	950 (25.5)	1600 (42.9)	2450 (65.7)	3550 (95.1)	3600 (96.5)	4250 (114)
	15	1.0	1550 (41.5)	2350 (62.9)	2900 (77.7)	4900 (131)	6450 (173)	7600 (204)
	20	1.4	1900 (50.9)	3000 (80.4)	4000 (107)	6700 (180)	9000 (241)	10400 (279)
	25	1.7	2300 (61.6)	3800 (102)	5250 (141)	8150 (218)	10300 (276)	13050 (350)
	30	2.1	2750 (73.7)	4750 (127)	6000 (161)	9700 (260)	12200 (327)	
	40	2.8	3400 (91.1)	5850 (157)	7550 (202)	12250 (328)		
	45	3.1	3650 (97.8)	6300 (169)	8800 (236)	13650 (366)		
	50	3.5	3950 (106)	7250 (194)	9300 (249)	15100 (405)		
	60	4.1	4650 (125)	8150 (218)	11000 (295)	16650 (446)		
	80	5.5	5850 (157)	10750 (288)	13750 (369)			
	100	6.9	7250 (194)	12850 (344)	17100 (458)			
	125	8.6	8700 (233)	15750 (422)				
10 PSIG (0.69 BAR)  655-697-010  ± 1% ABS ±0.25 PSIG (0.10 BAR)	10	0.69	300 (8.04)	400 (10.7)	350 (9.38)	400 (10.7)	400 (10.7)	450 (12.1)
	15	1.0	350 (9.38)	450 (12.1)	650 (17.4)	750 (20.1)	850 (22.8)	1100 (29.5)
	20	1.4	350 (9.38)	650 (17.4)	700 (18.8)	900 (24.1)	1350 (36.2)	1350 (36.2)
	25	1.7	450 (12.1)	800 (21.4)	950 (25.5)	1200 (32.2)	1500 (40.2)	1900 (50.9)
	30	2.1	700 (18.8)	900 (24.1)	1050 (28.1)	1200 (32.2)	1900 (50.9)	
	40	2.8	700 (18.8)	1100 (29.5)	1150 (30.8)	1850 (49.6)		
	45	3.1	750 (20.1)	1100 (29.5)	1300 (34.8)	2100 (56.3)		
	50	3.5	800 (21.4)	1200 (32.2)	1300 (34.8)	2300 (61.6)		
	60	4.1	850 (22.8)	1300 (34.8)	1450 (38.9)	2300 (61.6)		
	80	5.5	950 (25.5)	1600 (42.9)	1600 (42.9)			
	100	6.9	1050 (28.1)	1950 (52.3)	2600 (69.7)			
	125	8.6	1050 (28.1)	2350 (62.9)				
10 PSIG (0.69 BAR)  655-697-010  ± 2% ABS ± 0.5 PSIG (0.20 BAR)	10	0.69	400 (10.7)	500 (13.4)	650 (17.4)	900 (24.1)	650 (17.4)	900 (24.1)
	15	1.0	450 (12.1)	550 (14.7)	850 (22.8)	1300 (34.8)	1550 (41.5)	1850 (49.6)
	20	1.4	450 (12.1)	1000 (26.8)	1100 (29.5)	1750 (46.9)	2200 (58.9)	2400 (64.3)
	25	1.7	550 (14.7)	1250 (33.5)	1600 (42.9)	2300 (61.6)	2700 (72.4)	3550 (95.1)
	30	2.1	800 (21.4)	1350 (36.2)	1800 (48.2)	2800 (75.0)	2800 (75.0)	
	40	2.8	1050 (28.1)	1650 (44.2)	2150 (57.6)	3500 (93.8)		
	45	3.1	1350 (36.2)	1900 (50.9)	2600 (69.7)	3700 (99.2)		
	50	3.5	1450 (38.9)	2100 (56.3)	2850 (76.4)	4300 (115)		
	60	4.1	1600 (42.9)	2300 (61.6)	3100 (83.1)	4400 (118)		
	80	5.5	2150 (57.6)	3000 (80.4)	4000 (107)			
	100	6.9	2450 (65.7)	3700 (99.2)	4950 (133)			
	125	8.6	2600 (69.7)	4450 (119)				

1. Limited due to boost

 - Shaded areas show where maximum operating inlet pressure for a given port diameter is exceeded.

**P200 O & H**

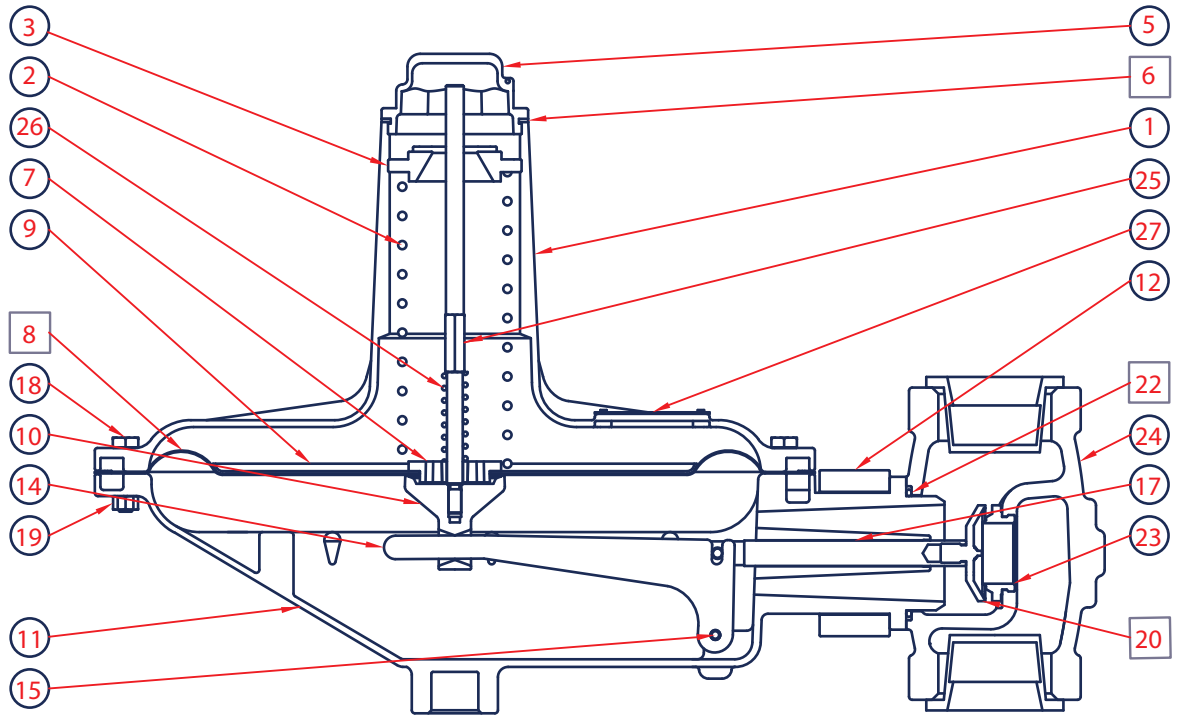

□ Parts included in P200 Low Pressure Repair Kit, 971-200-000

**P201 K**

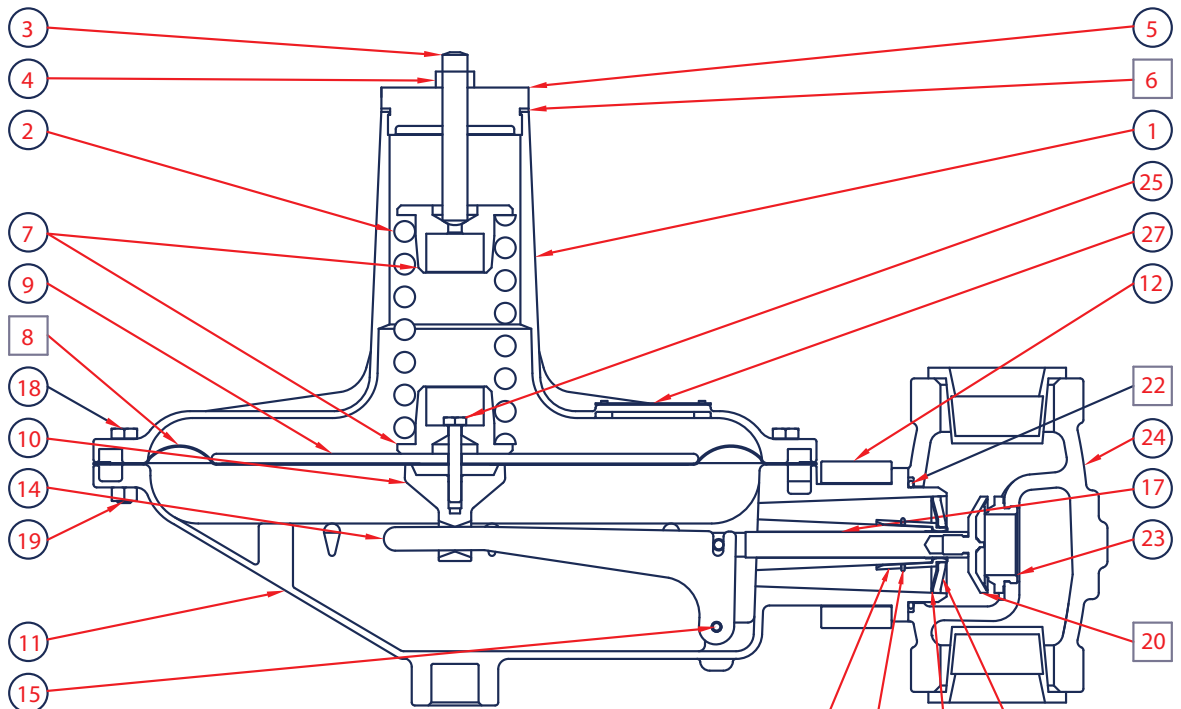

□ Parts included in 971-200-000, T201K Repair Kit

◇ Parts included in 971-200-005, T200 Stabilizer Kit



## P200 Parts List

Item	Description	Part Number
1	Bonnet (All except H/ 2-5 PSI)	604-230-000
	Pinned Spring Case (for 655-697-009 only)	800-132-000
2	Range Spring	See Table 2
3	Adjusting Screw	648-504-000
	Adjusting Screw (P201K only)	648-462-000
4	Hex Nut (P201K Only)	634-000-056
5	Closing Cap	610-058-000
	Closing Cap (P201K only)	610-061-000
6	Closing Cap Gasket	624-068-000
7	Upper/Lower Spring Seat	650-134-000
	Upper/Lower Spring Seat (P201K only)	626-105-000
8	Diaphragm, Nitrile	618-072-000
	Diaphragm, (P201K only), Nitrile	618-089-000
9	Diaphragm Head (P201 and P202)	628-277-000
	Diaphragm Head (P201H and P202H)	628-279-000
	Diaphragm Head (P201K only)	628-280-000
10	Pusher Post (P201, P201H, P201K & P201S)	637-326-000
	Pusher Post (P202, P202H & P201S)	637-317-000
11	Lower Casing Assembly	629-219-000
12	Union Ring	644-056-000
13	Spring Pin	635-065-000
14	Lever	730-000-000
15	Pin	635-064-000
16	Machine Screw	648-503-000
17	Valve Stem Assembly	827-013-000
18	Cap Screw	648-506-000
19	Hex Nut	634-174-000
20	Disk Holder Assembly, Nitrile	822-033-000
21	Cap Screw	648-506-001
22	O-Ring, Nitrile	649-000-152
23	Orifice, 1/4"	688-016-000
	Orifice, 3/8"	688-016-001
	Orifice, 1/2"	688-016-002
	Orifice, 3/4"	688-016-003
	Orifice, 1"	688-016-004
	Orifice, 1-3/16"	688-016-005
24	Iron Body, 2" NPT	664-309-000
	Steel Body, 2" NPT	664-342-000
	Iron Body, 1.5" NPT	664-345-000
	Steel Body, 1.5" NPT	664-347-000
	Iron Body, 1.25" NPT	664-345-001
	Steel Body, 1.25" NPT	664-347-001
	Iron Body, 1.5 x 2" NPT	664-349-000
	Steel Body, 1.5 x 2" NPT	664-349-001
	Iron Body, 125 FF 10", 2"	664-377-000
	Steel Body, 150 RF 10", 2"	664-378-000
25	Steel Body, 150 RF 10", 1.5"	664-393-000
	Cap Screw (P201 and P201H)	648-506-003
	Cap Screw (P201K only)	648-506-002
26	Stem (P202, P202H & P201S)	648-505-000
	Relief Valve Spring (P202, 202H & P201S)	655-697-001
27	Nameplate	632-526-000
28	Flapper Stem	661-008-000
29	Lower Flapper	661-009-000
30	Upper Flapper	661-010-000
31	Seat Ring	650-136-000
32	Self-Tapping Screw	648-502-000
33	Vent Port Spring	655-697-000
34	Screen	647-018-000
35	Snap Ring	693-021-000
66	Stabilizer Gasket (P201S and P202S)	624-088-000
67	Stabilizer Frame (P201S and P202S)	704-008-000
68	Stabilizer Snap Ring (P201S and P202S)	693-028-000
69	Stabilizer Neck (P201S and P202S)	608-084-000

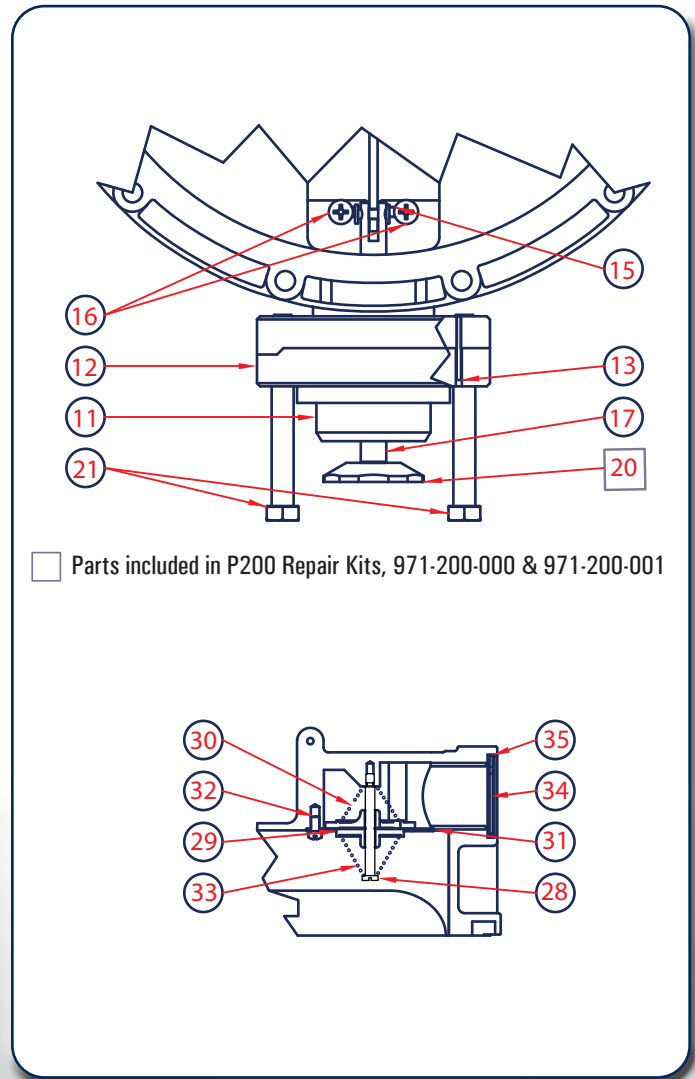

**P200P Parts List**

Item	Description	Qty.	Part Number
11	Lower Casing	1	629-219-001
17	Valve Stem	1	651-097-001
36	Retaining Ring	1	693-027-000
37	O-ring	1	649-000-005
38	O-ring	1	649-309-004
39	Wiper Ring	1	644-061-000
40	Stem Adaptor	1	653-058-000

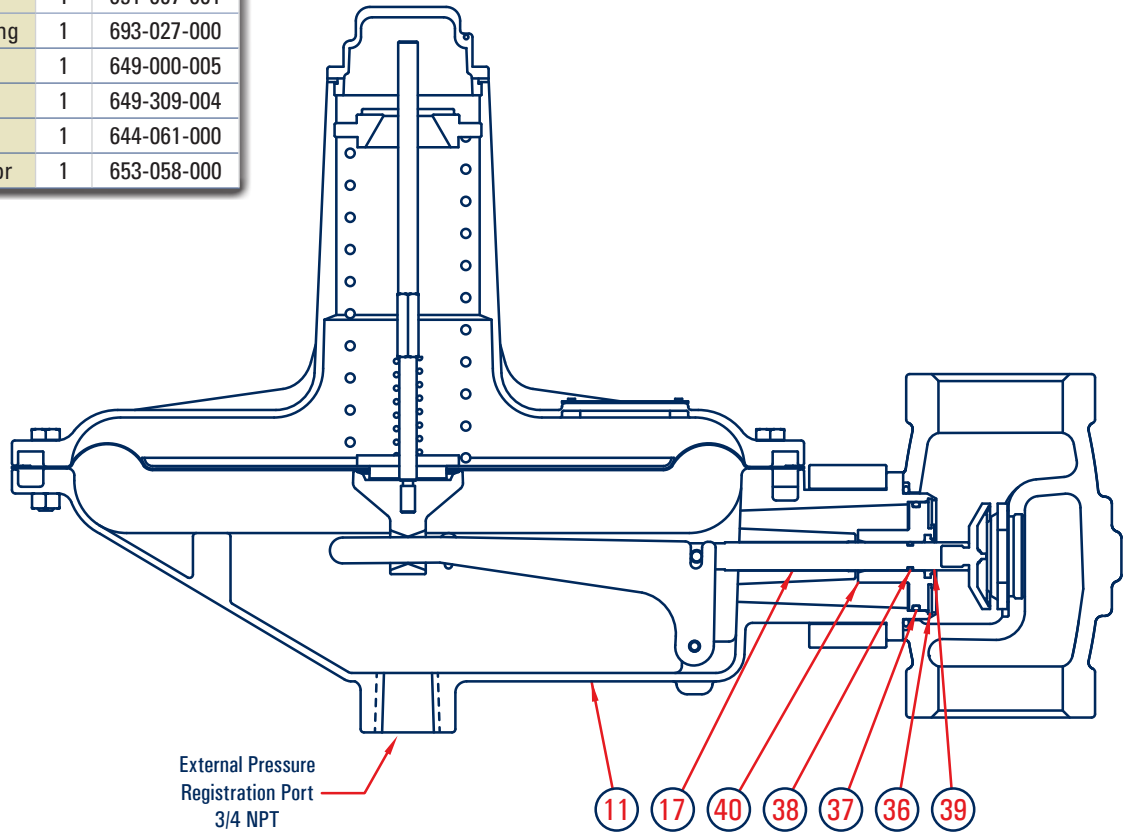

**P200P Body Orientation\***

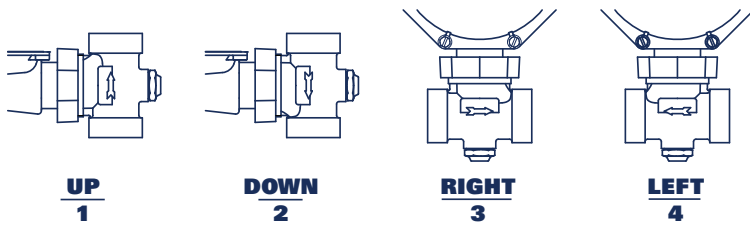

\* Port orientation is based on the body's "Out" port location in relation to the top view of the regulator.

**P200P Vent Positions**

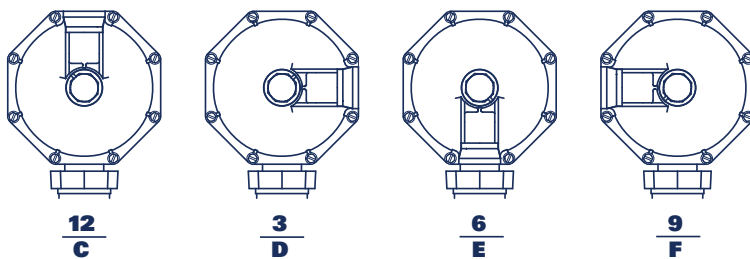

# F200 Pilot Operated Pressure Regulator

- External or Internal Pressure Registration
- Minimize Sudden Downstream Load Change
- Ideal for Fix Factor Billing
- Quick Response Time / High Accuracy

The F200 series is a manual, direct acting, self-operating, spring loaded, adjustable regulator. The F200 series is used in applications where pressure reduction is required. The regulator will reduce the risk of "shock" from abrupt changes of downstream conditions. This can help prevent safety equipment from shutting an operation down.

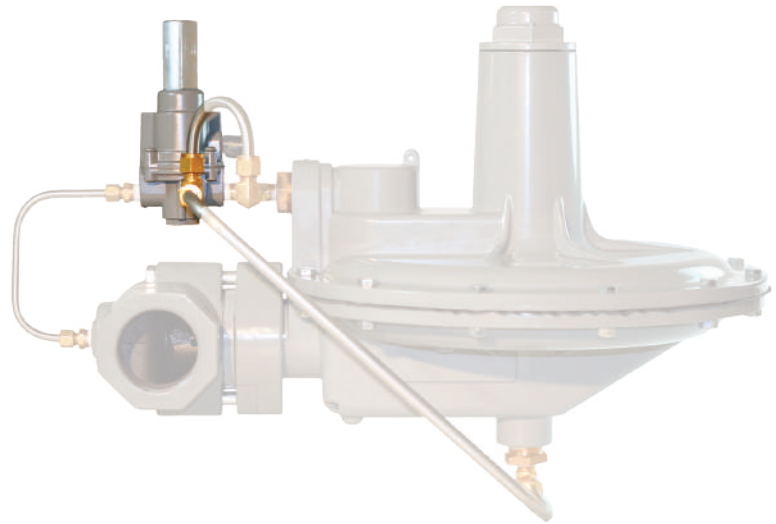

## Applications

- Compressors
- Gas Engines
- Service Regulators

## Materials of Construction

Adjusting Screw	Aluminum / Zinc Plated Steel
Body	Ductile Cast Iron or WCB Steel
Bonnet	Aluminum
Closing Cap	Aluminum
Diaphragm	Nitrile
Lower Casing	Aluminum
Molded Seat Assembly	Nitrile
Orifice	Aluminum
Upper/Lower Spring Seat	Aluminum / Brass
Flange	Ductile Cast Iron / WCB Steel

## F200 Series Maximum Inlet Pressure

Orifice Inches	Range	Maximum Inlet Pressure	
		PSIG	BAR
1/4"	Any	125	8.618
3/8"	Any	125	8.618
1/2"	Any	100	6.894
3/4"	Any	60	4.136
1"	Any	25	1.723
1-3/16"	Any	15	1.034

## Specifications

Maximum Inlet	See Table 1	
Maximum Emergency Outlet	15 PSIG	
Pressure Ranges	See Table 2	
Port Sizes	1.25 NPT	
	1.5 NPT	
	1.5 NPT x 2 NPT	
	2 NPT	
Orifice Sizes	1/4"	
	3/8"	
	1/2"	
	3/4"	
	1"	
	1-3/16"	
End Connections	NPT	
	150 RF Flange	Steel Units Only
	125 FF Flange	Iron Units Only
Temperature Range	-20°F to 180°F	
	-29°C to 82°C	
Approx. Weight	27 lbs. (12.25 kg)	

## F200 Main Spring Ranges

Model	Spring Ranges		Spring Color	Part Number
	WC or PSIG	mBAR		
F200	4 - 14 WC	14.94 - 34.87	Red	655-697-003
	14 - 2 PSIG	34.87 - 137.89		
F200	PSIG	BAR		
	2 - 10	0.137 - 0.689	Black	655-697-004

## F200 Pilot Spring Ranges

Model	Spring Ranges		Spring Color	Part Number
	WC or PSIG	mBAR		
F200	4 - 14 WC	14.94 - 34.87	White	655-765-000
	14 - 2 PSIG	34.87 - 137.89	Yellow	655-749-000
	PSIG	BAR		

## F200 Part Matrix

F200		0													
															Version
	<b>D</b>														Internal Registration
	<b>P</b>														External Registration
															Port Size
															1.25 NPT
															1.5 NPT
															1.5 x 2 NPT
															2 NPT
															Spring Range - WC or PSI / mBAR
															4 - 14" WC      10 - 35
															14" - 2 PSIG      35 - 138
															2 - 10 PSIG      138 - 689
															Place Holder
															Special Construction
															None
															150 RF (1.5" & 2" Steel Only)
															125 FF (2" Iron Only)
															Orifice
															4      1/4"
															6      3/8"
															8      1/2"
															<b>B</b> 3/4"
															<b>D</b> 1"
															<b>F</b> 1-3/16"
															Port Orientation
															<b>3</b> Right
															<b>4</b> Left
															Body Material
															<b>0</b> Iron
															<b>2</b> Steel

## F200 Dimensions

Body Size	A			B	C	D		
	Inches	NPT	125 FF Flange			150 RF Flange	NPT	125 FF Flange
1.25	6.13			11.03	18.09	1.85		
1.5	6.13		10	11.03	18.09	1.85		2.5
1.5 x 2	6.13			11.03	18.09	1.85		
2	6.13	10	10	10.59	17.66	2.15	4.42	4.42

## F200 Standard

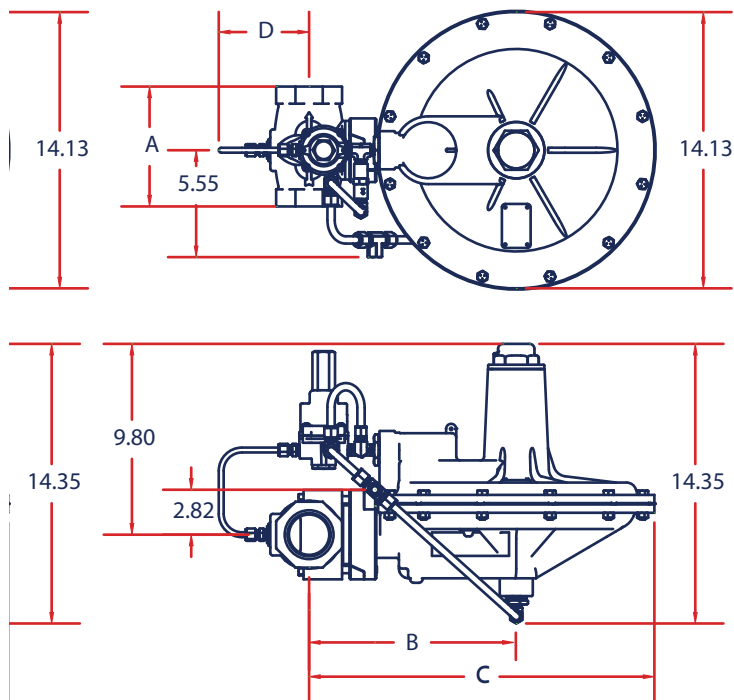

**F200D Flow Capacities in SCFH** of 0.6 Specific Gravity Natural Gas

Outlet Pressure, Spring Part Number, and Accuracy	Inlet Pressure		NPT 2 (DN 50) Body Sizes					
			Orifice Size, Inches (mm)					
	PSIG	BAR	1/4	3/8	1/2	3/4	1	1-3/16
4 inches WC (15 mbar) 655-697-003 1" WC Droop	2	0.14	697	1576	3123	4901	7009	6730
	5	0.34	999	2596	4568	8477	9402	8568
	10	0.69	1517	3577	6329	12387	11613	10219
	15	1.00	1835	4367	7753	13161	12697	11303
	25	1.70	2632	6185	12015	15871	14168	
	30	2.10	2903	6619	12387	15484		
	60	4.10	4707	11535	19742	17032		
	75	5.17	6200	14632	18581			
	100	6.90	7974					
	125	8.60	8825					
7 inches WC (17 mbar) 655-697-003 1" WC Droop	2	0.14	650	1626	2671	4835	7432	7742
	5	0.34	1006	2582	4346	8524	9414	5574
	10	0.69	1533	3750	5806	12000	13279	10245
	15	1.00	1835	4586	7907	15097	14710	11806
	25	1.70	1835	6908	11342	17806	16258	
	30	2.10	2942	6674	11674	17419		
	60	4.10	4877	11321	19355	18194		
	75	5.17	6286	15148	20903			
	100	6.90	7897					
	125	8.60	8826					
1 PSIG / 0.069 BAR 655-697-003 1% Droop	2	0.14	530	1379	2300	4102	6635	8195
	5	0.34	1030	2599	4205	8193	12227	12307
	10	0.69	1548	3799	6252	12636	17814	16490
	15	1.00	1870	4817	7805	16656	20013	16689
	25	1.70	2690	6968	10967	22735	21215	
	30	2.10	2870	7082	12494	22875		
	60	4.10	4800	11343	19941	25990		
	75	5.17	5820	14074	23788			
	100	6.90	7900	16241	29032			
	125	8.60	9850	11159				

1. Limited due to boost

- Shaded areas show where maximum operating inlet pressure for a given port diameter is exceeded.

2. When using the 4" to 14" range spring in combination with the 3/8" or 1/2" orifice, the boost to the outlet pressure (P2) will exceed 1% of the set pressure when the inlet pressure (P1) is above 30 PSIG. This will occur only on the internal registration model (D) and does not occur on the external registration model (P).

**F200 Flanged**

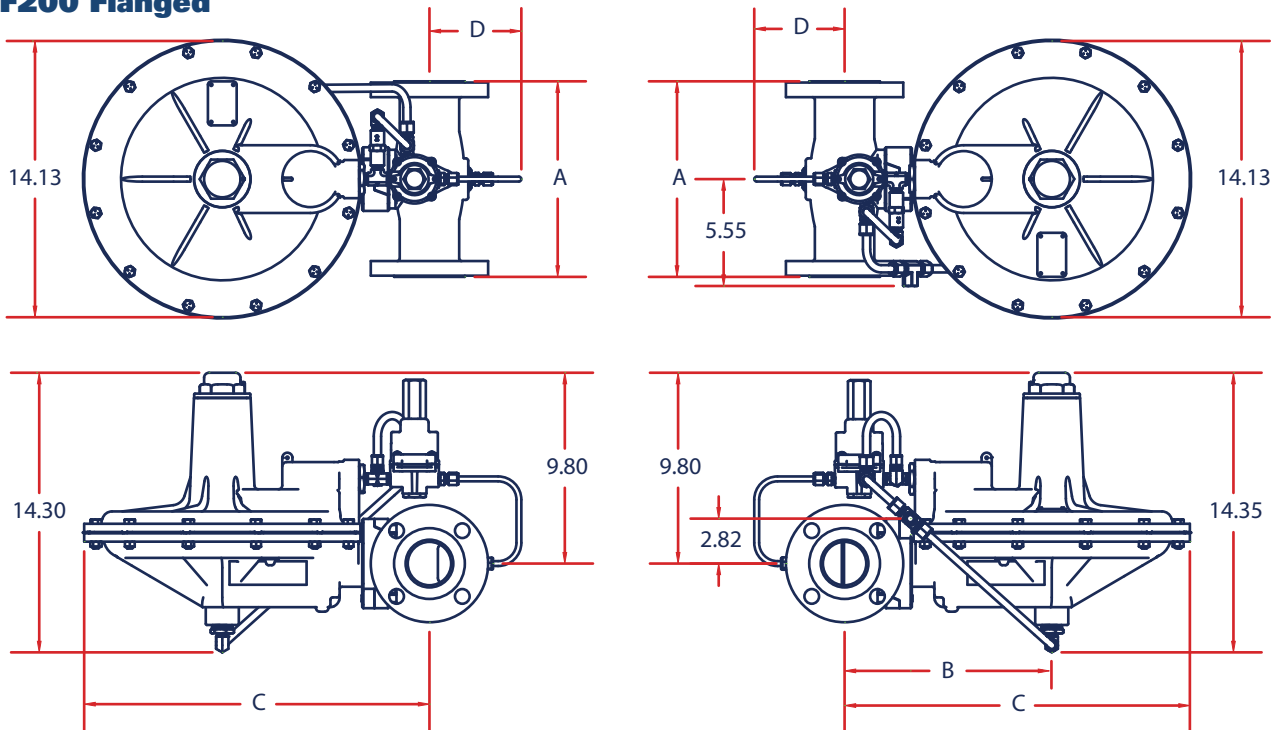

Outlet Pressure, Spring Part Number, and Accuracy	Inlet Pressure		NPT 2 (DN 50) Body Sizes					
			Orifice Size, Inches (mm)					
	PSIG	BAR	1/4	3/8	1/2	3/4	1	1-3/16
2 PSIG / 0.138 BAR 655-697-004 1% Droop	5	0.34	885	2204	3876	7918	11296	13256
	10	0.69	1500	3638	6120	11761	17727	15753
	15	1.00	1872	4697	7826	15924	20141	17475
	25	1.70	2605	6880	11090	23775	22475	
	30	2.10	2816	7139	12465	25837		
	60	4.10	4600	11116	19794	26585		
	75	5.17	5763	15070	23514			
	100	6.90	7600	17534	29662			
	125	8.60	8910	21383				
2 PSIG / 0.138 BAR 655-697-004 1% Droop	5	0.34	914	2200	3684	7356	11198	13236
	10	0.69	1525	3547	5804	11212	17230	16737
	15	1.00	1874	4566	7609	16223	19974	17335
	25	1.70	2607	6892	11098	23785	23328	
	30	2.10	2817	7267	12367	23716		
	60	4.10	4740	11421	19742	27821		
	75	5.17	6200	14490	23297			
	100	6.90	7500	18396	28595			
	125	8.60	8846	22076				
5 PSIG / 0.345 BAR 655-697-004 1% Droop	10	0.69	1269	3082	5173	10665	13034	17165
	15	1.00	1740	4343	7501	14764	22517	19215
	25	1.70	2641	6899	11045	18844	24540	
	30	2.10	2877	6672	12462	24553		
	60	4.10	4770	11591	19461	31796		
	75	5.17	6236	14801	22500			
	100	6.90	8137	18096	28504			
	125	8.60	8893	21553				
10 PSIG / 0.689 BAR 655-697-004 1% Droop	15	1.00	1430	3476	6027	11837	14849	18153
	25	1.70	2584	6899	11045	18844	29278	
	30	2.10	2897	6421	12346	22853		
	60	4.10	4810	8926	19405	37290		
	75	5.17	6394	14869	21782			
	100	6.90	8155	17656	28725			
	125	8.60	8925	21365				

1. Limited due to boost

- Shaded areas show where maximum operating inlet pressure for a given port diameter is exceeded.

2. When using the 4" to 14" range spring in combination with the 3/8" or 1/2" orifice, the boost to the outlet pressure (P2) will exceed 1% of the set pressure when the inlet pressure (P1) is above 30 PSIG. This will occur only on the internal registration model (D) and does not occur on the external registration model (P).

## F200 Parts List

Item	Description	Qty.	Part Number
2	Closing Spring 4" WC - 2 PSIG	1	655-697-003
	Closing Spring 2 - 10 PSIG		655-697-004
7	Diaphragm Relief Plug	1	650-134-000
8	Diaphragm	1	618-072-000
9	Diaphragm Head	2	628-277-000
10	Pusher Post	1	637-326-001
11	Lower Casing Assembly F200D	1	629-219-002
	Lower Casing Assembly F200P		629-219-001
17	Valve Stem Assembly F200D	1	827-013-000
	Valve Stem Assembly F200P		827-013-001
24	2 NPT	Iron Body	664-443-000
		Steel Body	664-443-001
	1.5 NPT	Iron Body	664-442-000
		Steel Body	664-442-002
	1.5 x 2 NPT	Iron Body	664-441-000
		Steel Body	664-441-001
	1.25 NPT	Iron Body	664-442-001
		Steel Body	664-442-003
	125 FF 10"	Iron Body	664-444-000
	150 RF 2"	Steel Body	664-444-001
150 RF 1.5"	Steel Body	664-444-002	
25	Stem	1	689-020-000
38	Retaining Ring (F200P Only)	1	693-027-000
39	O-ring Lg (F200P Only)	1	649-309-004
40	O-ring (F200P Only)	1	649-000-005
41	Wiper Ring (F200P Only)	1	644-061-000
42	Stem Adaptor (F200P Only)	1	653-058-000
60	Spring Retainer	1	626-121-000
61	Hex Nut	1	634-000-054
63	Spring Seat	1	650-198-000
64	Case Bushing 3/4 x 1/4	1	622-076-000
65	Bonnet Bushing 1 x 1/4	1	622-075-000
66	Tee M1/4 x M1/4 x M1/4	1	622-077-000
67	Relief Valve	1	678-061-000
68	Relief Valve Tubing	1	660-124-000
69	Right Angle Tee 1/4 x 3/8 x 3/8	1	622-074-000
70	Straight 1/4 x 1/4 Fitting	2	622-045-000
71	Pilot Supply Tubing	1	660-122-000
72	Elbow 1/4 x 3/8	2	622-061-000
73	In-Line Tee F1/4 x 3/8 x 3/8 (F200P Only)	1	622-078-000
74	Sensing Tubing F200D	1	660-123-000
75	Sensing Tubing F200P Short End	1	660-125-000
76	Sensing Tubing F200P Long End	1	660-126-000
77	PL84 Pilot 4" - 14" WC	1	832-036-000
	PL84 Pilot 14" WC - 2 PSIG		832-036-001
	PL84 Pilot 2 - 10 PSIG		832-036-002

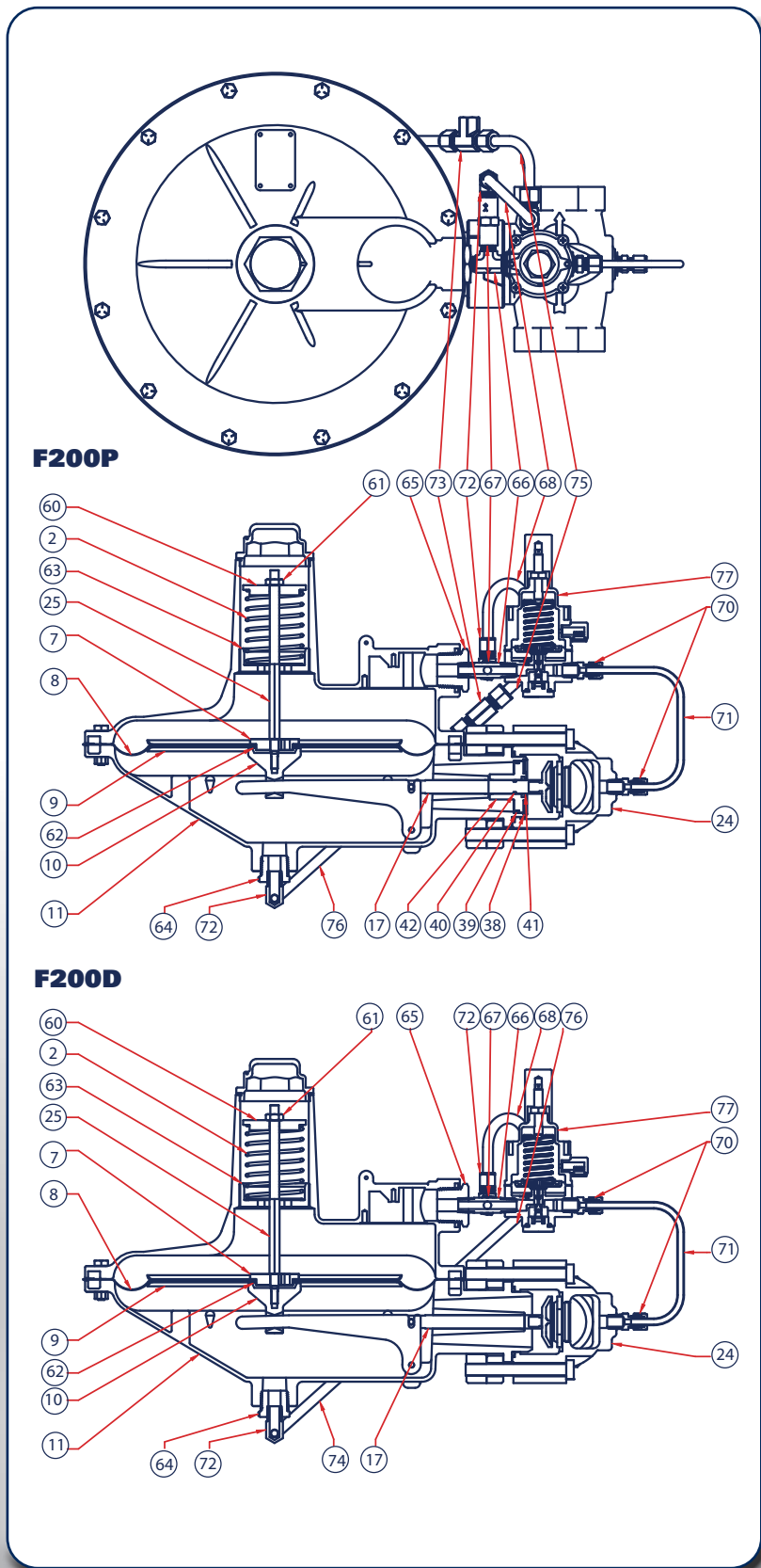

## F200 Body Orientation\*

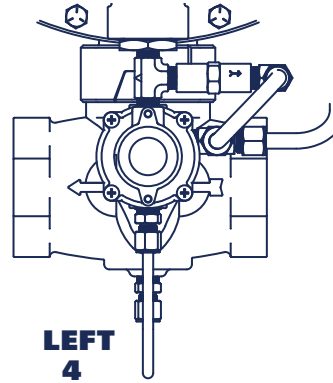
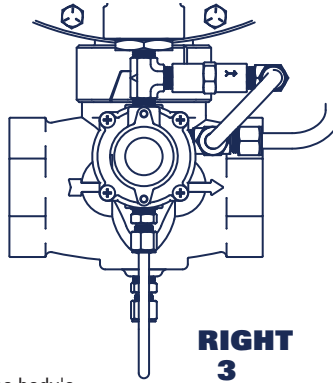

\* Port orientation is based on the body's "Out" port location in relation to the top view of the regulator.

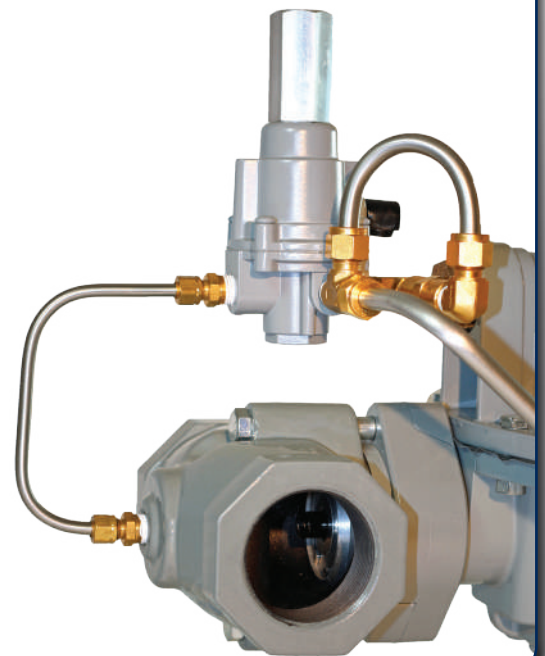
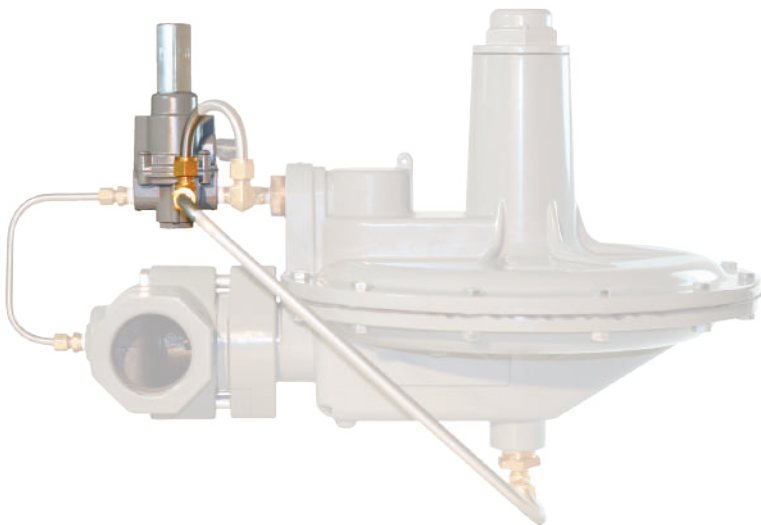

# P203 Pressure Reducing Regulator

The P203 and P203H are available with a true monitor regulator, which acts independently of the main regulator. The monitor provides equivalent overpressure protection when compared to a standard two-regulator monitor setup. If one regulator fails, the other regulator provides control and overpressure protection.

## Applications

- Commercial / Industrial / Service
- Gas Engine Control
- Gate Applications

## Features

- Integral Monitoring
- Fast Acting Minimizing Shock
- Internal Relief

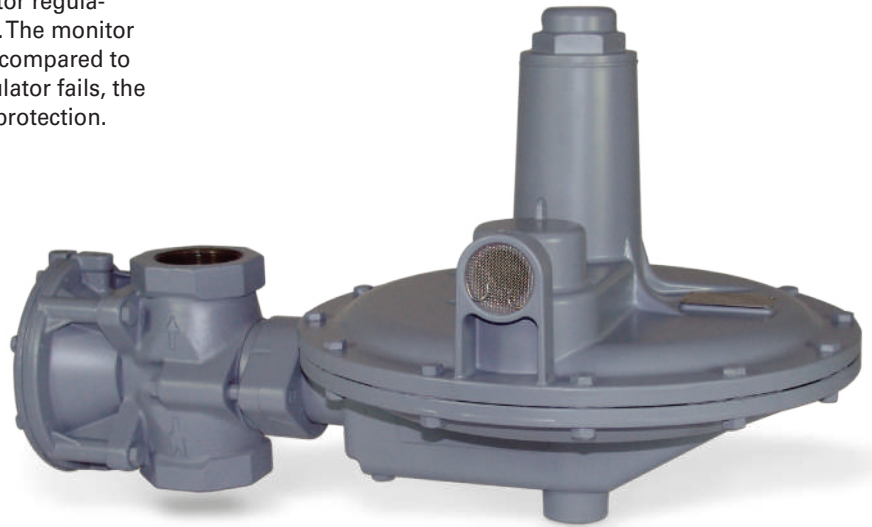

## Materials of Construction

Adjusting Screw	Aluminum
Body	Ductile Cast Iron
Bonnet	Aluminum
Closing Cap	Aluminum
Diaphragm	Nitrile
Lower Casing	Aluminum
Molded Seat Assembly	Nitrile
Orifice	Aluminum

## Specifications

Maximum Inlet	See Table 1	
Maximum Emergency Outlet	15 PSIG	
Port Sizes	1.5 NPT	
	1.5 NPT x 2 NPT	
	2 NPT	
Orifice Sizes	1/4"	
	3/8"	
	1/2"	
	3/4"	
	1"	
	1-3/16"	
End Connections	NPT	
	125 FF Flange	2" Iron Units Only
Temperature Range	-20°F to 180°F	
	-29°C to 82°C	

## P203 Max Inlet Pressures

Orifice Inches	Range	Maximum Inlet Pressure	
		PSIG	BAR
1/4"	Any	125	8.618
3/8"	Any	125	8.618
1/2"	Any	100	6.894
3/4"	Any	60	4.136
1"	0-5" WC thru 0.5-1.0 PSIG	25	1.723
	1-1.6 thru 1.25-3.25 PSIG	30	2.068
1-3/16"	0-5" WC thru 0.5-1.0 PSIG	13	0.896
	1-1.6 thru 1.25-3.25 PSIG	14	0.965

Type	Control Spring Part Number and Color	Maximum Downstream Pressure with Integral Monitor in Operation		Maximum Flow Through Internal Relief Valve with Integral Monitor in Operation <sup>1</sup>		Monitor Spring Number & Color	Outlet Pressure Range		Number of Lower Spring Seats
		PSIG	mBAR	SCFH	Nm <sup>3</sup> /h		WC or PSIG	mBAR	
P203	655-697-002, Brown	0.8	60	950	25.5	655-746-000, Green	0-5" WC	0-12	0
	655-697-003, Red	0.8	60	1000	26.8		4-9.5" WC	10-24	1
	655-697-004, Black						8-14" WC	20-35	2
	655-697-005, White	1.4	100	1200	32.2	655-746-001, Red	8-12" WC	20-30	0
		1.4	100	1350	36.2		10-20" WC	25-50	1
		1.8	120	1600	42.9	655-746-002, Blue	11-21" WC	27-52	0
		2.2	150	1800	48.2	655-746-001, Red	14-28" WC	35-70	2
	655-697-006, Dark Green	2.8	190	1900	50.9	655-746-002, Blue	18-33" WC	45-82	1
		3.0	210	2000	53.6	655-746-003, Silver	0.5-1.0 PSIG	34-69	0
	P203H	655-697-007, Dark Blue	3.0	210	2200	60.0	655-746-002, Blue	1.0-1.6 PSIG	69-110
3.8			260	2200	60.0	655-746-003, Silver	0.75-1.6 PSIG	52-110	1
655-697-008, Orange		4.0	280	2500	67.0	655-746-003, Silver	1.25-2.25 PSIG	86-155	2
		5.0	350	3000	80.4	655-746-003, Silver	1.25-3.25 PSIG	86-224	3
6.0		410	3000	80.4					

1. Flow of 0.6 specific gravity natural gas in SCFH at 60°F and 14.7 PSIA and Nm<sup>3</sup>/h at 0°C and 1.01325 BAR.

## How Does the P203 Series Work?

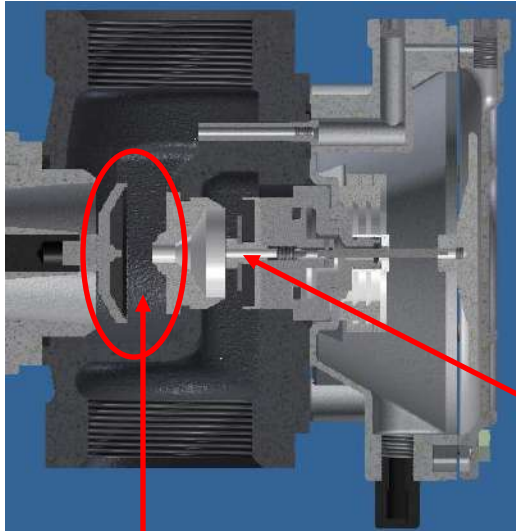

Under normal operational conditions, the P203 Series performs as the P200. When there is a demand downstream of the regulator, the main valve disk moves away from the orifice to allow flow. The Monitor diaphragm and piston are always in motion based on outlet feedback through the pitot tube at the outlet.

Secondary or monitor orifice & valve disk

Main orifice & valve disk

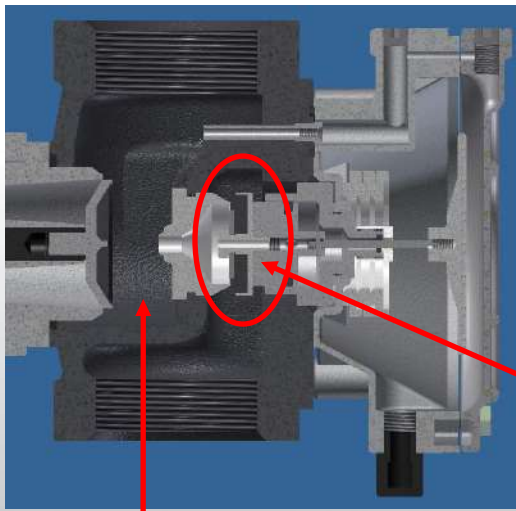

The monitor module will activate when the system experiences a failure such as the main valve disk is stuck open or the lever disengages from the valve stem assembly. When the P203 main regulator fails to regulate and the output pressure climbs, the increased output pressure will move the monitor valve disk towards the secondary sealing surface of the orifice.

Monitor valve disk starts to regulate

Main seat lodged open

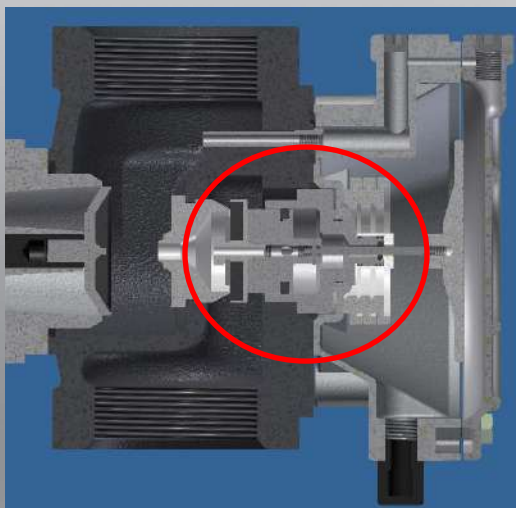

Once the output pressure has increased 7" to 28" WC above the set operating output pressure, the monitor valve disk will fully seal on the secondary sealing surface of the orifice. At this point, the only supply pressure that is passing through the unit is passing through the tiny bleed hole on the disk holder screw and venting directly out the main regulator diaphragm assembly and through the main regulator's vent assembly.

## BelGAS P203 Part Number Selection

Before attempting to select a BelGAS P203, several pieces of information should be known: port size, the supply pressure the unit operates at normally, the output pressure the unit operates at normally, the downstream flow requirement during normal operation, the maximum amount of output pressure the unit is allowed to have during an over pressurization situation, and the media the unit will be regulating.

### Example #1

#### Known Requirements

1.5 NPT  
60 PSIG inlet  
9" WC outlet under normal conditions  
18,000 SCFH air  
Should not rise above 1.3 PSIG

#### Port Size

The code of for 1.5 NPT in the Port Size section is 14.  
P203X14XX0XXXXX

#### Outlet Pressure Range

It's best to operate in the middle of the range in order to preserve the life of the unit's springs. Since the output pressure is supposed to be a 9" WC during normal operation, the unit could be either the G2 or R0 option from the Monitor Range section. G2 has a range of 8-14" WC and R0 has a range of 8-12" WC. That means the code for the Spring Coordination section is 18 and the code for the Version section is 0.

P203014180XXXG2 or P203014180XXXR0

#### Downstream Flow Requirements

The unit needs to flow at least 18,000 SCFH under normal operation. According to P200 Series flow tables for that spring range and outlet pressure droop, both the 1/2" orifice and the 3/4" orifice generated more than 18,000 SCFH. The 1/2" orifice generates 19,300 SCFH flow of air. The 3/4" orifice generates 20,000 SCFH flow of air.

P2030141808XXG2 or P2030141808XXR0  
or P203014180BXXG2 or P203014180BXXR0

#### Body and Bonnet Orientation

BelGAS offers sixteen different body/bonnet orientation combination controlled through two digits in the part number.

If no special orientation is required the 1D orientation is selected.

P20301418081DG2 or P20301418081DR0 or P203014180B-1DG2 or P203014180B1DR0

#### Over Pressurization Conditions

Since the unit cannot climb above 1.3 PSIG, the R0 option for Monitor Range section is eliminated. The R0 option for the Monitor Range can climb to 1.4 PSIG per the table of the catalog.

P20301418081DG2 or P203014180B1DG2

Based on the criteria provided, both regulators listed above can handle the application. However, the 3/4" orifice will flow more than the 1/2" orifice. So if more flow rate is desir-

able in this particular function: P203014180B1DG2

### Example #2

#### Known Requirements

2" 125 FF  
40 PSIG inlet  
2.4 PSIG outlet under normal conditions  
12,000 SCFH air  
Rotometer present downstream of the regulator

#### Port Size

The code for 2" 125FF in the Port Size section is 16. In the Special Construction section, you should put code E.  
P203X16XXEXXXXX

#### Version

Since there is a rotometer downstream of the regulator. the code for the Version selection should be an S. This allows for the installation of a throat stabilizer in the neck of the regulator. The stabilizer will allow the unit to function with minimal amount of cavitation.

P203S16XXEXXXXX

#### Outlet Pressure Range

It's best to operated in the middle of the range in order to preserve the life of the unit's springs. Since the output pressure is supposed to be at 2.4 PSIG during normal operation, the unit should be the S3 option from the Monitor Range section. S3 has a range of 1.25 - 3.25 PSIG. That means the code for the Spring Coordination section is 03.

P203S1603EXXXX3

#### Downstream Flow Requirements

The unit needs to flow at least 12,000 SCFH under normal operation. According to the P200 Series flow tables for that spring range and outlet pressure droop, the 3/4" orific can generate more than 12,000 SCFH. The 3/4" orifice generates 13,800 SCFH flow of air.

P203S1603EBXXS3

#### Body and Bonnet Orientation

BelGAS offers sixteen different body/bonnet orientation combination controlled through two digits in the part number. If no special orientation is required, the 1D orientaten is selected.

P203S1603EB4FS3

## P203 Dimensions

Body Size	A		B	C	D	
	Inches	NPT			NPT	125 FF Flange
1.5	6.13		11.03	18.09	4.18	
1.5 x 2	6.13		11.03	18.09	4.18	
2	6.13	10	10.59	17.66	4.61	4.61

## P203 Regulator Rebuild Kits

	Kit Includes	Part Number
P203	<b>Main Regulator</b> - Diaphragm, disk holder assembly, cap gasket and body/lower casing O-ring. <b>Monitor</b> - disk holder assembly, diaphragm, pilot tube O-ring, piston guide O-rings, piston ring, and piston assembly O-ring	971-203-000

## P203 Stabilizer Kit

	Kit Includes	Part Number
P203, P203H, and P203S	Stabilizer kit for downstream dampening	971-200-004

## P203 Conversions Kits

	Kit Includes	Part Number
P203 and P203S	Brown main spring, green monitor spring, no spring seats	971-203-0G0
	Red main spring, green monitor spring, one spring seat	971-203-6G1
	Black main spring, green monitor spring, one spring seat	971-203-9G1
	White main spring, green monitor spring, two spring seats	971-203-0G2
	White main spring, red monitor spring, no spring seats	971-203-0R0
	White main spring, red monitor spring, one spring seat	971-203-0R1
	White main spring, blue monitor spring, no spring seats	971-203-0B0
	Green main spring, red monitor spring, two spring seats	971-203-0R2
	Green main spring, blue monitor spring, one spring seat	971-203-0B1
P203H and P203S	Green main spring, silver monitor spring, no spring seats	971-203-0S0
	Blue main spring, blue monitor spring, two spring seats	971-203-0B2
	Blue main spring, silver monitor spring, one spring seat	971-203-0S1
	Orange main spring, silver monitor spring, two spring seats	971-203-0S2
	Orange main spring, silver monitor spring, three spring seats	971-203-0S3

### P203 2" NPT 125FF

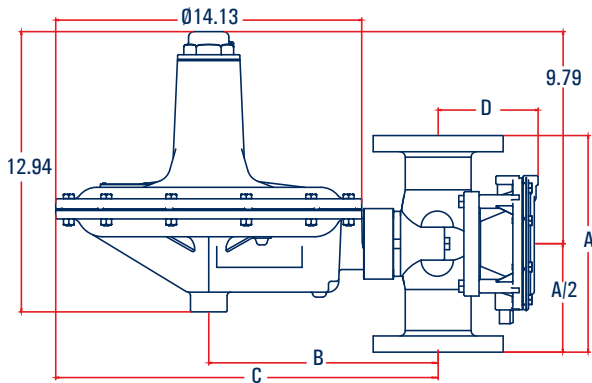

### P203 2" NPT

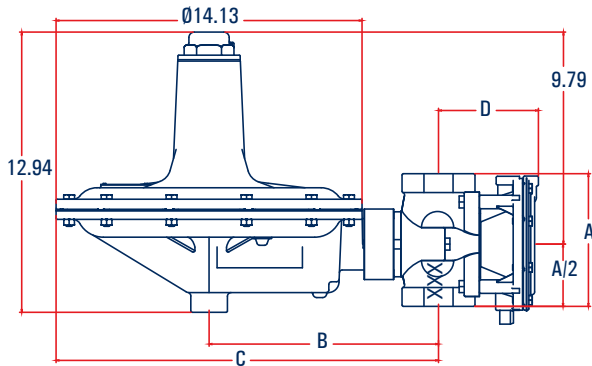

### P203 1-1/2" NPT

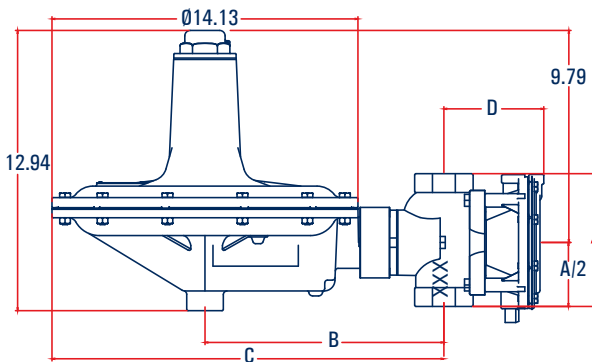

## P203 Part Matrix

P203									
									Version
<b>O</b>									Normal
<b>H</b>									High Pressure
<b>P</b>									External Pressure Registration
<b>S</b>									Throat Stabilizer
									Port Size
<b>14</b>									1.5 NPT
<b>15</b>									1.5 x 2 NPT
<b>16</b>									2 NPT
									Spring Range
<b>04</b>									use with G0 Monitor
<b>06</b>									use with G1 Monitor
<b>09</b>									use with G1 Monitor
<b>18</b>									use with G2, R0, R1, B0 Monitor
<b>30</b>									use with R2, B1, S0 Monitor
<b>02</b>									use with B2, S1 Monitor
<b>03</b>									use with S2, S3 Monitor
									Special Construction
<b>0</b>									MPT
									Orifice
<b>4</b>									1/4"
<b>6</b>									3/8"
<b>8</b>									1/2"
<b>B</b>									3/4"
<b>D</b>									1"
<b>F</b>									1-3/16"
									Port Orientation
<b>1</b>									Up (Standard)
<b>2</b>									Down
<b>3</b>									Right
<b>4</b>									Left
									Bonnet Vent Orientation
<b>C</b>									12 O'Clock
<b>D</b>									3 O'Clock (Standard)
<b>E</b>									6 O'Clock
<b>F</b>									9 O'Clock
									Monitor Ranges
									WC or PSIG
									BAR
<b>G0</b>									0-5" WC
<b>G1</b>									4 - 9.5" WC
<b>G2</b>									8-14" WC
<b>R0</b>									8-12" WC
<b>R1</b>									10 - 20" WC
<b>R2</b>									14 - 28" WC
<b>B0</b>									11 - 21" WC
<b>B1</b>									18 - 33" WC
<b>S0</b>									0.5 -1 PSIG
<b>B2</b>									1.0 - 1.6 PSIG
<b>S1</b>									0.75 - 1.6 PSIG
<b>S2</b>									1.25 - 2.25 PSIG
<b>S3</b>									1.25 - 3.25 PSIG
									0 - 11.20
									9.96 - 23.66
									19.92 - 34.87
									19.92 - 29.89
									24.90 - 49.81
									54.87 - 69.74
									27.39 - 52.30
									44.83 - 82.19
									34.47 - 68.94
									68.94 - 110.31
									51.71 - 110.31
									86.18 - 155.13
									86.18 - 224.07
									use with 04 Main Spring
									use with 06 or 09 Main Spring
									use with 18 Main Spring
									use with 18 Main Spring
									use with 18 Main Spring
									use with 30 Main Spring
									use with 18 Main Spring
									use with 30 Main Spring
									use with 30 Main Spring
									use with 02 Main Spring
									use with 02 Main Spring
									use with 03 Main Spring
									use with 03 Main Spring
									use with 03 Main Spring

Note: Monitor Range should be chosen prior to choosing Main Spring

Note: Monitor Range should be chosen prior to choosing Main Spring

### P203 Normal (0) Relief Capacities

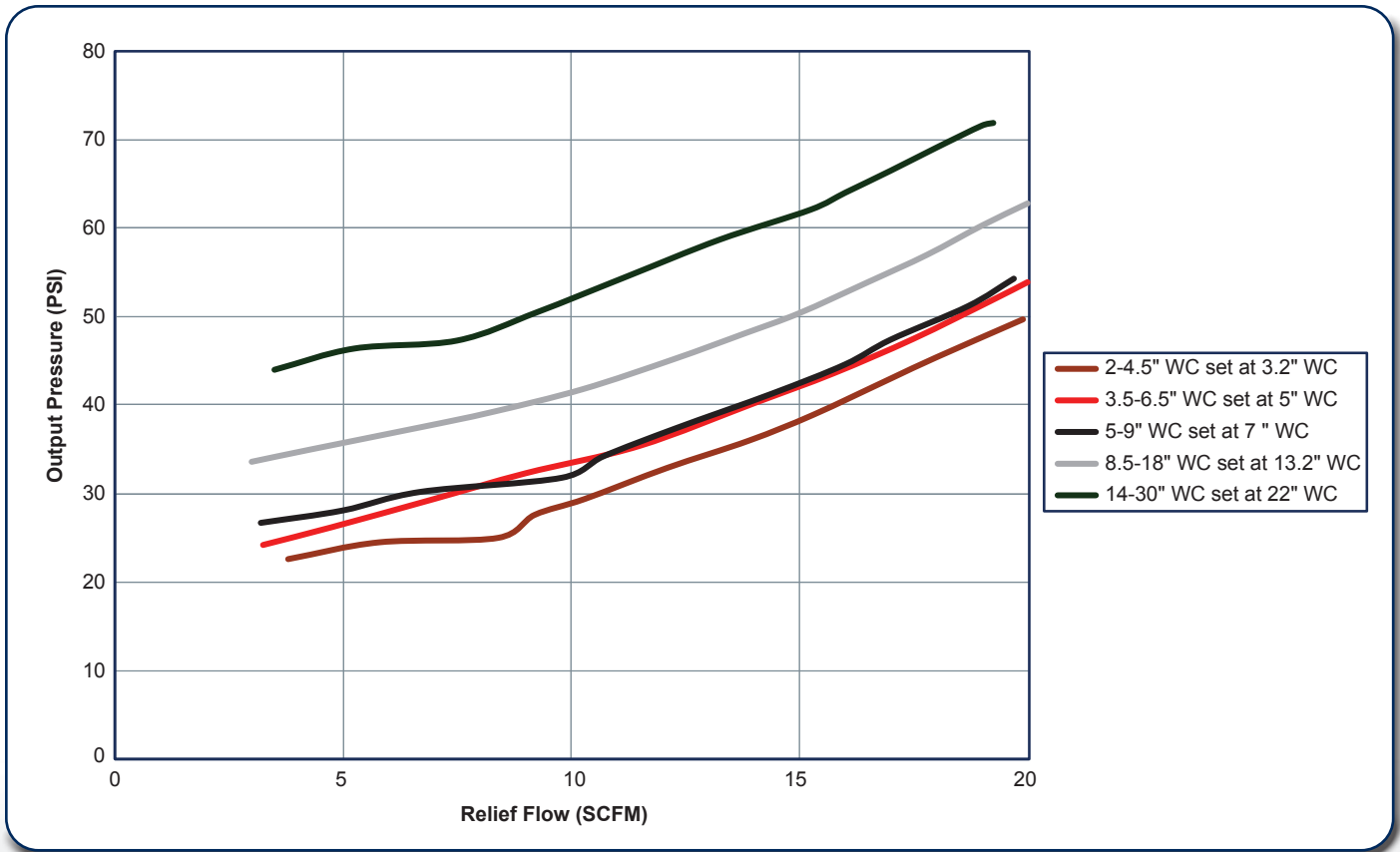

### P203 High (H) Relief Capacities

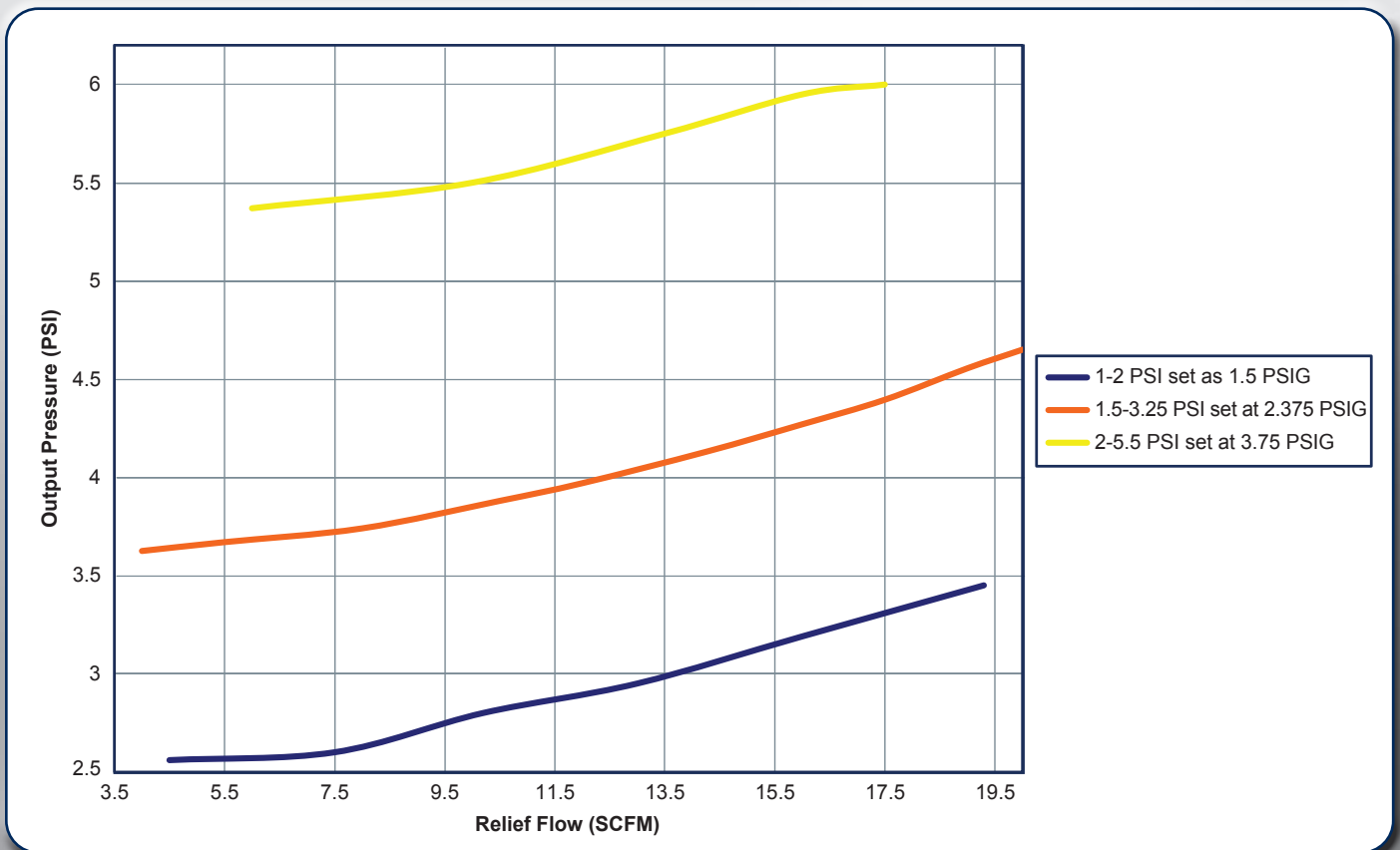

## P203 Flow Capacities in SCFH (Nm<sup>3</sup>/h) of 0.6 Specific Gravity Natural Gas

Outlet Pressure, Spring Part Number, and Accuracy	Inlet Pressure		NPT 1-1/2 Body Size					
			Orifice Size, Inches (mm)					
	PSIG	BAR	1/4 (6.4)	3/8 (9.5)	1/2 (13)	3/4 (19)	1 (25)	1-3/16 (30)
4 inches w.c. (10 mbar)  655-697-002 or 655-697-003  1 inch w.c. (2 mbar) droop 2 inches w.c. (5 mbar) boost	0.4	0.028				1000 (26.8)	1400 (37.5)	1600 (42.8)
	0.5	0.034				1400 (37.5)	1600 (42.8)	1800 (48.2)
	1	0.07	400 (10.7)	800 (21.4)	1200 (32.2)	2100 (56.3)	2500 (67.0)	2700 (72.4)
	1.5	0.10	500 (13.4)	1050 (28.1)	1600 (42.9)	2500 (67.0)	3000 (80.4)	3200 (85.8)
	2	0.14	600 (16.1)	1300 (34.8)	2100 (56.3)	2800 (75.0)	3500 (93.8)	3800 (102)
	5	0.34	1150 (30.8)	2200 (58.9)	3300 (88.4)	4500 (121)	5300 (142)	6000 (161)
	13	0.90	1600 (42.8)	3600 (96.4)	6200 (166)	7000 (188)	6000 (161)	6850 (184)
	25	1.7	2550 (68.3)	5000 (134)	7350 (197)	8950 (240)	9000 (241)	
	60	4.1	4750 (127)	5100 (137)	7050 (189)	5600 (150) <sup>(1)</sup>		
	100	6.9	6650 (186)	7300 (196)	5200 (139) <sup>(1)</sup>			
125	8.6	6950 ( )	8300 (222)					
7 inches w.c. (17 mbar)  655-697-004  1 inch w.c. (2 mbar) droop 2 inches w.c. (5 mbar) boost	0.4	0.028				900 (24.1)	1300 (34.8)	1450 (38.9)
	0.5	0.034				1200 (32.2)	1550 (41.5)	1750 (46.9)
	1	0.07	400 (10.7)	800 (21.4)	1100 (29.5)	1900 (50.9)	2300 (61.6)	2500 (67.0)
	1.5	0.10	500 (13.4)	1050 (28.1)	1500 (40.2)	2300 (61.6)	2800 (75.0)	1800 (48.2)
	2	0.14	600 (16.1)	1300 (34.8)	1900 (50.9)	2100 (56.3)	3300 (88.4)	1800 (48.2)
	5	0.34	950 (25.5)	2100 (56.3)	3200 (85.8)	3350 (89.8)	5100 (137)	4500 (121)
	13	0.90	1600 (42.8)	2200 (58.9)	3300 (88.4)	5800 (155)	8000 (214)	8000 (214)
	25	1.7	2200 (58.9)	5200 (139)	6800 (182)	8400 (225)	8750 (235)	
	60	4.1	4300 (115)	9200 (247)	10100 (271)	9900 (265)		
	100	6.9	7500 (201)	10500 (281)	9200 (247) <sup>(1)</sup>			
125	8.6	9050 (243)	9800 (263) <sup>(1)</sup>					
11 inches w.c. (17 mbar)  655-697-005  ± 2 inches w.c. (5 mbar)	0.5	0.03				800 (21.4)	1500 (40.2)	1700 (45.6)
	1	0.07	400 (10.7)	700 (18.7)	1100 (29.5)	1800 (48.2)	2200 (58.9)	2450 (65.7)
	1.5	0.10	500 (13.4)	950 (25.5)	1450 (38.9)	2300 (61.6)	2800 (75.0)	2600 (69.7)
	2	0.14	600 (16.1)	1200 (32.2)	1700 (45.6)	1950 (52.3)	3200 (85.8)	2750 (73.7)
	5	0.34	950 (25.5)	2000 (53.6)	2900 (77.7)	3800 (102)	5100 (137)	5150 (138)
	13	0.90	1600 (42.8)	3400 (91.1)	3700 (99.2)	6100 (163)	7250 (194)	7650 (205)
	25	1.7	2100 (56.3)	5150 (138)	7100 (190)	7950 (213)	9400 (252)	
	60	4.1	4400 (118)	9250 (248)	9400 (252)	10400 (279)		
	100	6.9	7300 (196)	10000 (268)	10100 (271)			
	125	8.6	9050 (243)	10800 (289)				
14 inches w.c. (35 mbar)  655-697-005  ± 2 inches w.c. (5 mbar)	1	0.07	450 (12.1)	800 (21.4)	1000 (26.8)	1250 (33.5)	1500 (40.2)	1950 (52.3)
	1.5	0.10	500 (13.4)	850 (22.8)	1050 (28.1)	1550 (41.5)	1650 (44.2)	2350 (62.9)
	2	0.14	550 (14.7)	1150 (30.8)	1400 (37.5)	1750 (46.9)	2300 (61.6)	2500 (67.0)
	5	0.34	1000 (26.8)	1200 (32.2)	2050 (54.9)	3000 (80.4)	4300 (115)	4750 (127)
	13	0.90	1750 (46.9)	3050 (81.7)	4250 (114)	6100 (163)	7300 (196)	7850 (210)
	25	1.7	2500 (67.0)	4750 (127)	5650 (151)	8700 (233)	8700 (233)	
	60	4.1	4750 (127)	9450 (253)	9950 (267)	10550 (283)		
	100	6.9	7450 (200)	10400 (279)	10600 (284)			
	125	8.6	9050 (243)	10450 (280)				
	20 inches w.c. (50 mbar)  655-697-006  ± 3 inches w.c. (7 mbar)	1	0.07	300 (8.04)	500 (13.4)	750 (20.1)	1000 (26.8)	1300 (34.8)
2		0.14	500 (13.4)	950 (25.5)	1400 (37.5)	2000 (53.6)	2800 (75.0)	3100 (83.1)
5		0.34	900 (24.1)	1700 (45.6)	2500 (67.0)	4200 (113)	5000 (134)	5500 (147)
13		0.90	1500 (40.2)	3200 (85.8)	5400 (145)	6500 (174)	7000 (188)	7100 (190)
25		1.7	2100 (56.3)	4700 (126)	7000 (188)	8250 (221)	9350 (251)	
60		4.1	4750 (127)	8900 (239)	9950 (267)	10600 (284)		
100		6.9	7400 (198)	10500 (281)	10800 (289)			
125		8.6	9200 (247)	10950 (293)				

1. Limited due to boost

 - Shaded areas show where indicated droop would be exceeded regardless of capacity.

 - Shaded areas show where maximum operating inlet pressure for a given port diameter is exceeded.

**P203 Flow Capacities in SCFH** (Nm<sup>3</sup>/h) of 0.6 Specific Gravity Natural Gas



Outlet Pressure, Spring Part Number, and Accuracy	Inlet Pressure		NPT 2 (DN 50) Body Size					
			Orifice Size, Inches (mm)					
	PSIG	BAR	1/4 (6.4)	3/8 (9.5)	1/2 (13)	3/4 (19)	1 (25)	1-3/16 (30)
4 inches w.c. (10 mbar) 655-697-002 or 655-697-003 1 inch w.c. (2 mbar) droop 2 inches w.c. (5 mbar) boost	0.4	0.028				1200 (32.3)	1600 (42.8)	1800 (48.2)
	0.5	0.034				1700 (45.6)	2200 (58.9)	2400 (64.3)
	1	0.07	400 (10.7)	900 (24.1)	1300 (34.8)	2800 (75.0)	3200 (85.8)	3800 (102)
	1.5	0.10	500 (13.4)	1100 (29.5)	1700 (45.5)	3600 (96.5)	4300 (115)	5000 (134)
	2	0.14	600 (16.1)	1400 (37.5)	2200 (58.9)	4500 (121)	5500 (147)	6400 (172)
	5	0.34	1000 (26.8)	2300 (61.6)	3700 (99.2)	7800 (209)	9500 (255)	12700 (340)
	13	0.90	1650 (44.2)	3700 (99.2)	6500 (174)	13000 (348)	14000 (375)	14500 (389)
	25	1.7	2500 (64.3)	5200 (139)	9200 (247)	13000 (348)	18000 (482)	
	60	4.1	4450 (119)	9000 (241)	14550 (390)	15000 (402)		
	100	6.9	5500 (147)	9500 (255)	12900 (346) <sup>(1)</sup>			
125	8.6	7250 (194)	3900 (105) <sup>(1)</sup>					
7 inches w.c. (17 mbar) 655-697-004 1 inch w.c. (2 mbar) droop 2 inches w.c. (5 mbar) boost	0.4	0.028				950 (25.5)	1400 (37.5)	1600 (42.8)
	0.5	0.034				1500 (40.2)	1800 (48.2)	2000 (53.6)
	1	0.07	400 (10.7)	800 (21.4)	1200 (32.2)	2300 (61.6)	2800 (75.0)	3300 (88.4)
	1.5	0.10	500 (13.4)	1050 (28.1)	1600 (42.8)	3100 (83.1)	3600 (96.5)	4500 (121)
	2	0.14	600 (16.1)	1300 (34.8)	2000 (53.6)	4000 (107)	4500 (121)	6000 (161)
	5	0.34	1000 (26.8)	2100 (56.3)	3500 (93.8)	7700 (206)	9400 (252)	9400 (252)
	13	0.90	1650 (44.2)	3500 (93.8)	6400 (172)	10000 (268)	20200 (541)	21200 (568)
	25	1.7	2400 (64.3)	5200 (139)	10300 (276)	20000 (536)	11800 (316) <sup>(1)</sup>	
	60	4.1	4450 (119)	9000 (241)	12000 (322)	20700 (555)		
	100	6.9	7500 (201)	10000 (268)	13100 (351)			
125	8.6	9500 (255)	10300 (276)					
11 inches w.c. (17 mbar) 655-697-005 ± 2 inches w.c. (5 mbar)	0.5	0.03				800 (21.4)	1500 (40.2)	1600 (42.8)
	1	0.07	400 (10.7)	750 (20.1)	1100 (29.5)	1800 (48.2)	2500 (64.0)	2600 (69.7)
	1.5	0.10	500 (13.4)	1000 (26.8)	1450 (38.9)	2500 (67.0)	3400 (91.1)	3350 (89.8)
	2	0.14	600 (16.1)	1200 (32.2)	1700 (45.6)	3100 (83.1)	3600 (113)	3750 (101)
	5	0.34	1000 (26.8)	2000 (53.6)	3000 (80.4)	7300 (196)	7000 (188)	8500 (228)
	13	0.90	1600 (42.9)	3400 (91.1)	6200 (166)	10350 (277)	17650 (473)	18100 (485)
	25	1.7	2400 (64.3)	5650 (151)	10350 (277)	19300 (517)	23450 (628)	
	60	4.1	4450 (119)	11350 (304)	19300 (517)	20200 (541)		
	100	6.9	7450 (200)	16650 (446)	20200 (541)			
	125	8.6	9500 (255)	17500 (469)				
14 inches w.c. (35 mbar) 655-697-005 ± 2 inches w.c. (5 mbar)	1	0.07	450 (12.1)	700 (18.8)	1100 (29.5)	1500 (40.2)	1700 (45.6)	2700 (72.4)
	1.5	0.10	550 (14.7)	850 (22.8)	1200 (32.3)	1900 (50.9)	2700 (72.4)	3600 (96.5)
	2	0.14	600 (16.1)	1000 (26.8)	1900 (50.9)	2800 (75.0)	3800 (102)	3800 (102)
	5	0.34	1050 (28.1)	1750 (46.9)	2800 (75.0)	4000 (107)	5300 (142)	10600 (284)
	13	0.90	1750 (46.9)	3700 (99.2)	5700 (153)	14400 (386)	18000 (482)	18500 (496)
	25	1.7	2600 (69.7)	5700 (153)	10200 (273)	18000 (482)	25400 (681)	
	60	4.1	4800 (129)	10900 (292)	11000 (295)	19600 (525)		
	100	6.9	7400 (198)	16500 (442)	14100 (378)			
	125	8.6	9100 (244)	18000 (482)				
	20 inches w.c. (50 mbar) 655-697-006 ± 3 inches w.c. (7 mbar)	1	0.07	300 (8.04)	750 (20.1)	550 (14.7)	1250 (33.5)	1700 (45.6)
2		0.14	500 (13.4)	1150 (30.8)	1700 (45.6)	1900 (50.9)	2350 (62.9)	3250 (87.1)
5		0.34	900 (24.1)	1650 (44.2)	2150 (57.6)	3250 (87.1)	6400 (172)	6700 (180)
13		0.90	1500 (40.2)	2550 (68.3)	4350 (117)	5950 (159)	10150 (272)	10500 (281)
25		1.7	2450 (65.7)	4850 (130)	7200 (193)	18100 (485)	19200 (515)	
60		4.1	4900 (131)	9400 (252)	19600 (525)	22700 (608)		
100		6.9	7500 (201)	17400 (466)	13800 (370)			
125		8.6	9150 (245)	5500 (147) <sup>(1)</sup>				

**P203 Flow Capacities in SCFH** (Nm<sup>3</sup>/h) of 0.6 Specific Gravity Natural Gas

Outlet Pressure, Spring Part Number, and Accuracy	Inlet Pressure		NPT 1-1/2 Body Size					
			Orifice Size, Inches (mm)					
	PSIG	BAR	1/4 (6.4)	3/8 (9.5)	1/2 (13)	3/4 (19)	1 (25)	1-3/16 (30)
1 PSIG (0.07 BAR) 655-697-006  ±0.2 PSIG (0.014 BAR)	2	0.14	700 (18.8)	1250 (33.5)	1550 (41.5)	2900 (77.7)	3050 (81.7)	3250 (87.1)
	5	0.34	1050 (28.1)	2150 (57.6)	2800 (75.0)	4800 (129)	5600 (150)	6300 (169)
	10	0.69	1650 (44.2)	3200 (85.8)	4400 (118)	6550 (176)	7800 (209)	8150 (218)
	15	1.0	2000 (53.6)	4100 (110)	5750 (154)	8000 (214)	9400 (252)	10250 (275)
	20	1.4	2300 (61.6)	4750 (127)	6100 (163)	8700 (233)	10950 (293)	
	25	1.7	2600 (69.7)	5500 (147)	8200 (220)	9950 (267)	11550 (310)	
	30	2.1	2900 (77.7)	6250 (168)	8350 (224)	10800 (289)	12250 (328)	
	40	2.8	3600 (96.5)	7500 (201)	9350 (251)	10850 (291)		
	45	3.1	3900 (105)	8400 (225)	10350 (277)	11000 (295)		
	50	3.5	4250 (114)	8900 (239)	10950 (293)	11050 (296)		
	60	4.1	4950 (133)	10000 (268)	11000 (295)	11400 (306)		
	80	5.5	6150 (165)	11150 (299)	11350 (304)			
	100	6.9	7500 (201)	12000 (322)	12000 (322)			
	125	8.6	9150 (245)	12000 (322)				
1 PSIG (0.07 BAR) 655-697-006  ± 1% ABS ±0.16 psia (0.011 BAR)	2	0.14	650 (17.4)	1050 (28.1)	1350 (36.2)	2450 (65.7)	2700 (72.4)	3000 (80.4)
	5	0.34	1050 (28.1)	2100 (56.3)	2700 (72.4)	3800 (102)	4700 (126)	5200 (139)
	10	0.69	1500 (40.2)	2800 (75.0)	3700 (99.2)	5600 (150)	7000 (188)	7300 (196)
	15	1.0	1950 (52.3)	3750 (101)	4900 (131)	6900 (185)	8500 (228)	8750 (235)
	20	1.4	2200 (58.9)	4600 (123)	5800 (155)	8150 (218)	10350 (277)	
	25	1.7	2500 (67.0)	5000 (134)	7250 (194)	9050 (243)	10850 (291)	
	30	2.1	2800 (75.0)	6000 (161)	8200 (220)	9400 (252)	11000 (295)	
	40	2.8	3550 (95.1)	7350 (197)	9100 (244)	9500 (255)		
	45	3.1	3900 (105)	8250 (221)	9650 (259)	10100 (271)		
	50	3.5	4050 (109)	8450 (226)	10300 (276)	10300 (276)		
	60	4.1	4800 (129)	9050 (243)	10450 (280)	10550 (283)		
	80	5.5	5900 (158)	11000 (295)	11100 (297)			
	100	6.9	7400 (198)	11150 (299)	11500 (299)			
	125	8.6	9000 (241)	11750 (315)				
1 PSIG (0.07 BAR) 655-697-006  ± 2% ABS ±0.31 psia (0.021 BAR)	2	0.14	750 (20.1)	1450 (38.9)	2100 (56.3)	3700 (99.2)	4650 (125)	5350 (143)
	5	0.34	1250 (33.5)	2500 (67.0)	3550 (95.1)	6050 (162)	7900 (212)	7900 (212)
	10	0.69	1750 (46.9)	3450 (92.5)	5100 (137)	8550 (229)	9550 (256)	10100 (271)
	15	1.0	2050 (54.9)	4350 (117)	6700 (180)	9400 (252)	11250 (302)	11400 (306)
	20	1.4	2500 (67.0)	5150 (138)	8100 (217)	10500 (281)	12200 (327)	
	25	1.7	2700 (72.4)	5800 (155)	10100 (271)	11550 (310)	12600 (338)	
	30	2.1	3050 (81.7)	6650 (178)	10550 (283)	12350 (331)	13100 (351)	
	40	2.8	3700 (99.2)	7950 (212)	10550 (283)	12350 (331)		
	45	3.1	4100 (110)	8800 (236)	11800 (316)	12700 (340)		
	50	3.5	4550 (122)	9250 (248)	12000 (322)	13000 (348)		
	60	4.1	5000 (134)	10900 (292)	12600 (338)	13000 (348)		
	80	5.5	6450 (173)	12550 (336)	13000 (348)			
	100	6.9	7950 (213)	12900 (346)	13450 (360)			
	125	8.6	9450 (253)	13450 (360)				
1 PSIG (0.07 BAR) 655-697-006  ±0.2 PSIG (0.014 BAR)	2	0.14	500 (13.4)	750 (20.1)	1750 (46.9)	2250 (60.3)	2400 (64.3)	2850 (76.4)
	5	0.34	1100 (29.5)	1800 (48.2)	2300 (61.6)	3400 (91.1)	4850 (130)	5350 (143)
	10	0.69	1600 (42.9)	3200 (85.8)	4600 (123)	7250 (194)	8800 (236)	8800 (236)
	30	2.1	2800 (75.0)	6300 (169)	7800 (209)	10400 (279)	11250 (302)	
	60	4.1	4900 (131)	9600 (257)	9650 (259)	11000 (295)		
	100	6.9	7300 (196)	11200 (300)	11950 (320)			
	125	8.6	9100 (244)	10550 (283) <sup>(1)</sup>				

1. Limited due to boost

 - Shaded areas show where maximum operating inlet pressure for a given port diameter is exceeded.

**P203 Flow Capacities in SCFH** (Nm<sup>3</sup>/h) of 0.6 Specific Gravity Natural Gas



Outlet Pressure, Spring Part Number, and Accuracy	Inlet Pressure		NPT 2 (DN 50) Body Size					
			Orifice Size, Inches (mm)					
	PSIG	BAR	1/4 (6.4)	3/8 (9.5)	1/2 (13)	3/4 (19)	1 (25)	1-3/16 (30)
1 PSIG (0.07 BAR)  655-697-006  ±0.2 PSIG (0.014 BAR)	2	0.14	650 (17.4)	1200 (32.2)	2200 (58.9)	3200 (85.8)	3600 (96.5)	4500 (121)
	5	0.34	1100 (25.5)	2300 (61.6)	3200 (85.8)	4800 (129)	7700 (206)	10000 (268)
	10	0.69	1600 (42.9)	3000 (80.4)	4300 (115)	11400 (306)	15200 (407)	16300 (437)
	15	1.0	1900 (50.9)	4000 (107)	6900 (185)	15600 (418)	20800 (557)	22300 (598)
	20	1.4	2300 (61.6)	4900 (131)	9100 (244)	19000 (509)	24000 (643)	
	25	1.7	2600 (69.7)	5600 (150)	10500 (281)	21700 (582)	27400 (734)	
	30	2.1	2900 (77.7)	6500 (174)	11800 (316)	25300 (678)	32800 (879)	
	40	2.8	3700 (99.2)	8000 (214)	14500 (389)	27000 (724)		
	45	3.1	4000 (107)	8800 (236)	15800 (423)	27000 (724)		
	50	3.5	4300 (115)	9300 (249)	16600 (445)	28000 (750)		
	60	4.1	4900 (131)	11300 (303)	19500 (523)	31600 (847)		
	80	5.5	6300 (169)	14200 (381)	24000 (643)			
	100	6.9	7700 (206)	16700 (448)	29500 (791)			
125	8.6	9600 (257)	20200 (541)					
1 PSIG (0.07 BAR)  655-697-006  ± 1% ABS ±0.16 psia (0.011 BAR)	2	0.14	570 (15.3)	1100 (29.5)	2000 (53.6)	2750 (73.7)	3100 (83.1)	4000 (107)
	5	0.34	1050 (28.1)	2200 (58.9)	2750 (73.7)	4100 (110)	6250 (168)	9000 (241)
	10	0.69	1500 (40.2)	2500 (67.0)	4050 (109)	8500 (228)	13250 (355)	13700 (367)
	15	1.0	1900 (50.9)	3450 (92.5)	5800 (155)	15500 (415)	16000 (429)	16300 (437)
	20	1.4	2300 (61.6)	4800 (129)	7700 (206)	18300 (490)	20850 (559)	
	25	1.7	2500 (67.0)	5600 (150)	10400 (279)	21500 (576)	22800 (611)	
	30	2.1	2900 (77.7)	6350 (170)	11950 (320)	23800 (638)	24300 (651)	
	40	2.8	3650 (97.8)	7850 (210)	14550 (390)	24300 (651)		
	45	3.1	3850 (103)	8400 (225)	15600 (418)	25400 (681)		
	50	3.5	4250 (114)	9350 (251)	16700 (448)	26000 (697)		
	60	4.1	4900 (131)	11200 (300)	19400 (520)	32000 (858)		
	80	5.5	6200 (166)	14250 (382)	24600 (659)			
	100	6.9	7400 (198)	16750 (449)	29000 (777)			
125	8.6	9350 (251)	20200 (541)					
1 PSIG (0.07 BAR)  655-697-006  ± 2% ABS ±0.31 psia (0.021 BAR)	2	0.14	700 (18.8)	1450 (38.9)	2450 (65.7)	4100 (110)	5600 (150)	7900 (212)
	5	0.34	1150 (30.8)	2550 (68.3)	4000 (107)	8000 (214)	11700 (314)	14300 (383)
	10	0.69	1800 (48.2)	3550 (95.1)	6200 (166)	12300 (330)	18400 (493)	20000 (536)
	15	1.0	2050 (54.9)	4450 (119)	7850 (210)	15900 (426)	22000 (590)	24600 (659)
	20	1.4	2400 (64.3)	5250 (141)	9100 (244)	19200 (515)	25800 (691)	
	25	1.7	2750 (73.7)	5900 (158)	10300 (276)	21800 (584)	31200 (836)	
	30	2.1	3150 (84.4)	6550 (176)	11800 (316)	26200 (702)	35000 (938)	
	40	2.8	3750 (101)	8200 (220)	14300 (383)	30500 (817)		
	45	3.1	4050 (109)	8800 (236)	15600 (418)	28100 (753)		
	50	3.5	4400 (118)	9300 (249)	16700 (448)	33900 (909)		
	60	4.1	5050 (135)	10850 (291)	19500 (523)	34200 (917)		
	80	5.5	6350 (170)	13600 (364)	24600 (659)			
	100	6.9	7850 (210)	17000 (456)	30200 (809)			
125	8.6	9400 (252)	20500 (549)					
1 PSIG (0.07 BAR)  655-697-006  ±0.2 PSIG (0.014 BAR)	2	0.14	500 (13.4)	1050 (28.1)	1400 (37.5)	2200 (58.9)	2900 (77.7)	3700 (99.2)
	5	0.34	1100 (29.5)	2000 (53.6)	2200 (58.9)	4500 (121)	6600 (177)	7000 (188)
	10	0.69	1600 (42.9)	3500 (93.8)	5700 (153)	9700 (260)	13000 (348)	13300 (356)
	30	2.1	2800 (75.0)	6200 (166)	11700 (314)	20000 (536)	23000 (616)	
	60	4.1	4900 (131)	10900 (292)	19300 (517)	20600 (552)		
	100	6.9	7500 (201)	17300 (464)	23900 (641)			
	125	8.6	9000 (241)	19900 (533)				

1. Limited due to boost

- Shaded areas show where maximum operating inlet pressure for a given port diameter is exceeded.

## P203 H Flow Capacities in SCFH (Nm<sup>3</sup>/h) of 0.6 Specific Gravity Natural Gas

Outlet Pressure, Spring Part Number, and Accuracy	Inlet Pressure		NPT 1-1/2 Body Size					
			Orifice Size, Inches (mm)					
	PSIG	BAR	1/4 (6.4)	3/8 (9.5)	1/2 (13)	3/4 (19)	1 (25)	1-3/16 (30)
2 PSIG (0.14 BAR) 655-697-007  ±0.2 PSIG (0.014 BAR)	5	0.34	850 (22.8)	1600 (42.9)	1650 (44.2)	2400 (64.3)	2450 (65.7)	3900 (105)
	10	0.69	1450 (38.9)	2050 (54.9)	3250 (87.1)	5400 (145)	5750 (154)	6650 (178)
	15	1.0	1650 (44.2)	3000 (80.4)	4300 (115)	7000 (188)	8200 (220)	8200 (220)
	20	1.4	2050 (54.9)	3850 (103)	5650 (151)	7500 (201)	9050 (243)	
	25	1.7	2500 (67.0)	4600 (123)	6500 (174)	9600 (257)	9700 (260)	
	30	2.1	2750 (73.7)	5650 (151)	6500 (174)	9600 (257)	10850 (291)	
	40	2.8	3500 (93.8)	7000 (188)	8400 (225)	10150 (272)		
	45	3.1	3750 (101)	7800 (209)	9150 (245)	10500 (281)		
	50	3.5	4250 (114)	8500 (228)	9600 (257)	10500 (281)		
	60	4.1	4850 (130)	8800 (236)	9700 (260)	11400 (306)		
	80	5.5	6150 (165)	10000 (268)	11250 (302)			
	100	6.9	7600 (204)	10800 (289)	11250 (302)			
	125	8.6	9300 (249)	12200 (327)				
2 PSIG (0.14 BAR) 655-697-007  ± 1% ABS ±0.04 psia (0.028 BAR)	5	0.34	1100 (29.5)	2200 (58.9)	2800 (75.0)	4550 (122)	5600 (150)	6550 (176)
	10	0.69	1750 (46.9)	3150 (84.4)	4600 (123)	7550 (202)	9050 (243)	10150 (272)
	15	1.0	2000 (53.6)	4200 (113)	6400 (172)	10050 (269)	11000 (295)	11200 (300)
	20	1.4	2400 (64.3)	5000 (134)	7550 (202)	11700 (314)	12200 (327)	
	25	1.7	2700 (72.4)	5750 (154)	9600 (257)	11900 (319)	12950 (347)	
	30	2.1	3100 (83.1)	6700 (180)	9600 (257)	11900 (319)	13300 (356)	
	40	2.8	3750 (101)	7950 (213)	10750 (288)	13000 (348)		
	45	3.1	4100 (110)	8750 (235)	10750 (288)	13000 (348)		
	50	3.5	4550 (122)	9550 (256)	12700 (340)	13000 (348)		
	60	4.1	5150 (138)	11250 (302)	13300 (356)	14400 (386)		
	80	5.5	6450 (173)	12750 (342)	13300 (356)			
	100	6.9	7750 (208)	14450 (387)	13300 (356)			
	125	8.6	9400 (252)	14600 (391)				
2 PSIG (0.14 BAR) 655-697-007  ± 1% ABS ±0.17 psia (0.012 BAR)	5	0.34	850 (22.8)	1400 (37.5)	1450 (38.9)	2250 (60.3)	2450 (65.7)	3300 (88.4)
	10	0.69	1400 (37.5)	1650 (44.2)	2550 (68.3)	4350 (117)	5250 (141)	5600 (150)
	15	1.0	1500 (40.2)	2700 (72.4)	3800 (102)	6000 (161)	5400 (145)	8000 (214)
	20	1.4	2000 (53.6)	3600 (96.5)	5200 (139)	7200 (193)	8200 (220)	
	25	1.7	2400 (64.3)	4500 (121)	6400 (172)	9000 (241)	9550 (256)	
	30	2.1	2800 (75.0)	5600 (150)	7500 (201)	10000 (268)	10400 (279)	
	40	2.8	3600 (96.5)	7800 (209)	9200 (247)	10150 (272)		
	45	3.1	3900 (105)	8400 (225)	9800 (263)	10900 (292)		
	50	3.5	4300 (115)	9100 (244)	10300 (276)	10600 (284)		
	60	4.1	5000 (134)	10200 (273)	11400 (306)	11300 (303)		
	80	5.5	6400 (172)	12000 (322)	10300 (276)(1)			
	100	6.9	7900 (212)	13000 (348)	11150 (299)(1)			
	125	8.6	9600 (257)	11950 (320)(1)				
2 PSIG (0.14 BAR) 655-697-007  ± 2% ABS ±0.33 psia (0.023 BAR)	5	0.34	1050 (28.1)	2100 (56.3)	2500 (67.0)	4100 (110)	5200 (139)	6250 (168)
	10	0.69	1650 (44.2)	3050 (81.7)	4200 (113)	6400 (172)	8350 (224)	8850 (237)
	15	1.0	1900 (50.9)	4200 (113)	6200 (166)	8800 (236)	10500 (281)	10750 (288)
	20	1.4	2200 (58.9)	5100 (137)	7600 (204)	10300 (276)	12000 (322)	
	25	1.7	2500 (67.0)	5800 (155)	8700 (233)	11800 (316)	12050 (323)	
	30	2.1	3000 (80.4)	6500 (174)	9600 (257)	12600 (338)	12700 (340)	
	40	2.8	3600 (96.5)	8100 (217)	11500 (308)	12700 (340)		
	45	3.1	3900 (105)	8800 (236)	12000 (322)	12800 (343)		
	50	3.5	4300 (115)	9700 (260)	12600 (338)	12900 (346)		
	60	4.1	5000 (134)	11300 (303)	13600 (364)	13700 (367)		
	80	5.5	6400 (172)	14200 (381)	12650 (339)			
	100	6.9	7900 (212)	15500 (415)	12950 (347)			
	125	8.6	9600 (257)	14200 (381)(1)				

1. Limited due to boost

 - Shaded areas show where maximum operating inlet pressure for a given port diameter is exceeded.

**P203 H Flow Capacities in SCFH** (Nm<sup>3</sup>/h) of 0.6 Specific Gravity Natural Gas



Outlet Pressure, Spring Part Number, and Accuracy	Inlet Pressure		NPT 2 (DN 50) Body Size					
			Orifice Size, Inches (mm)					
	PSIG	BAR	1/4 (6.4)	3/8 (9.5)	1/2 (13)	3/4 (19)	1 (25)	1-3/16 (30)
2 PSIG (0.14 BAR)  655-697-007  ±0.2 PSIG (0.014 BAR)	5	0.34	850 (22.8)	1800 (48.2)	1800 (48.2)	2950 (79.1)	4250 (114)	5200 (139)
	10	0.69	1350 (36.2)	1900 (50.9)	3000 (80.4)	5200 (139)	6600 (177)	7800 (209)
	15	1.0	1700 (45.6)	2800 (75.0)	3700 (99.2)	6900 (185)	7200 (193)	9500 (255)
	20	1.4	2000 (53.6)	3800 (102)	5300 (142)	9000 (241)	9800 (263)	
	25	1.7	2450 (65.7)	4500 (121)	6800 (182)	12500 (335)	14200 (381)	
	30	2.1	2650 (71.0)	5200 (139)	7500 (201)	16000 (429)	16100 (431)	
	40	2.8	3400 (91.1)	7400 (198)	13200 (354)	21600 (579)		
	45	3.1	3600 (96.1)	8000 (214)	15500 (415)	21600 (579)		
	50	3.5	4000 (107)	8500 (228)	16700 (448)	21900 (587)		
	60	4.1	4600 (123)	10700 (287)	19200 (515)	18800 (504) <sup>(1)</sup>		
	80	5.5	5800 (155)	13100 (351)	24800 (665)			
	100	6.9	7100 (190)	16200 (434)	25600 (686)			
	125	8.6	9000 (241)	19900 (533)				
2 PSIG (0.14 BAR)  655-697-007  ±0.4 PSIG (0.028 BAR)	5	0.34	1100 (29.5)	2250 (60.3)	3200 (85.8)	5500 (147)	7800 (209)	10100 (271)
	10	0.69	1600 (42.9)	3250 (87.1)	5400 (145)	10000 (268)	14100 (378)	15100 (405)
	15	1.0	2000 (53.6)	4150 (111)	7200 (193)	14400 (386)	18600 (498)	22100 (592)
	20	1.4	2300 (61.6)	4950 (133)	9000 (241)	17500 (469)	24000 (643)	
	25	1.7	2650 (71.0)	5800 (155)	10200 (273)	20700 (555)	28000 (750)	
	30	2.1	3100 (83.1)	6600 (177)	11800 (316)	24900 (667)	28500 (764)	
	40	2.8	3600 (96.5)	8100 (217)	14600 (391)	28000 (750)		
	45	3.1	4100 (110)	8850 (237)	15800 (423)	29000 (777)		
	50	3.5	4400 (118)	9850 (264)	17200 (461)	29200 (783)		
	60	4.1	4900 (131)	11300 (303)	19500 (523)	29300 (785)		
	80	5.5	6400 (172)	14300 (383)	24500 (657)			
	100	6.9	7600 (204)	17200 (461)	29700 (796)			
	125	8.6	9400 (252)	20500 (549)				
2 PSIG (0.14 BAR)  655-697-007  ± 1% ABS ±0.17 psia (0.012 BAR)	5	0.34	750 (20.1)	1600 (42.9)	1600 (42.9)	2400 (64.3)	3000 (80.4)	4100 (110)
	10	0.69	1250 (33.5)	1600 (42.9)	2550 (68.3)	4250 (114)	5000 (134)	6100 (163)
	15	1.0	1600 (42.9)	2700 (72.4)	3800 (102)	5200 (139)	6900 (185)	7600 (204)
	20	1.4	2000 (53.6)	3600 (96.5)	5200 (139)	6900 (185)	9400 (252)	
	25	1.7	2450 (65.7)	4400 (118)	7500 (201)	9600 (257)	10650 (285)	
	30	2.1	2800 (75.0)	5200 (139)	8600 (230)	11800 (316)	16100 (431)	
	40	2.8	3700 (99.2)	7500 (201)	12200 (327)	16200 (434)		
	45	3.1	4100 (110)	8400 (225)	15200 (407)	18350 (492)		
	50	3.5	4400 (118)	9000 (241)	16900 (453)	21000 (563)		
	60	4.1	5100 (137)	11000 (295)	20800 (557)	21000 (563)		
	80	5.5	6500 (174)	14600 (391)	24800 (665)			
	100	6.9	8000 (214)	18000 (482)	29300 (785)			
	125	8.6	9800 (263)	20500 (549)				
2 PSIG (0.14 BAR)  655-697-007  ± 2% ABS ±0.33 psia (0.023 BAR)	5	0.34	1000 (26.8)	2150 (57.6)	2750 (73.7)	5000 (134)	6200 (166)	7900 (212)
	10	0.69	1550 (41.5)	3050 (81.7)	5000 (134)	8600 (230)	12750 (342)	13800 (370)
	15	1.0	1900 (50.9)	4200 (113)	7200 (193)	11000 (295)	11750 (315)	21700 (582)
	20	1.4	2300 (61.6)	5100 (137)	9200 (247)	14200 (381)	16000 (429)	
	25	1.7	2600 (69.7)	5900 (158)	10700 (287)	16400 (440)	25400 (681)	
	30	2.1	3000 (80.4)	6600 (177)	12100 (324)	19700 (528)	27900 (748)	
	40	2.8	3700 (99.2)	8200 (220)	12200 (327)	27200 (729)		
	45	3.1	4100 (110)	9000 (241)	15200 (407)	27200 (729)		
	50	3.5	4400 (118)	9700 (260)	16900 (453)	27400 (734)		
	60	4.1	5100 (137)	11300 (303)	20800 (557)	27400 (734)		
	80	5.5	6500 (174)	14600 (391)	24500 (657)			
	100	6.9	8000 (214)	18000 (482)	29600 (793)			
	125	8.6	9800 (263)	20500 (549)				

1. Limited due to boost

- Shaded areas show where maximum operating inlet pressure for a given port diameter is exceeded.

## P203 H Flow Capacities in SCFH (Nm<sup>3</sup>/h) of 0.6 Specific Gravity Natural Gas

Outlet Pressure, Spring Part Number, and Accuracy	Inlet Pressure		NPT 1-1/2 Body Size					
			Orifice Size, Inches (mm)					
	PSIG	BAR	1/4 (6.4)	3/8 (9.5)	1/2 (13)	3/4 (19)	1 (25)	1-3/16 (30)
3 PSIG (0.21 BAR) 655-697-008  ±0.3 PSIG (0.021 BAR)	5	0.34	800 (21.4)	1350 (36.2)	1650 (44.2)	2500 (67.0)	2500 (67.0)	3850 (103)
	10	0.69	1200 (32.2)	1800 (48.2)	2650 (71.0)	4600 (123)	6050 (162)	6600 (177)
	15	1.0	1650 (44.2)	2300 (61.6)	3750 (101)	5600 (174)	9200 (247)	8200 (220)
	20	1.4	1950 (52.3)	3500 (93.8)	5000 (134)	8350 (224)	9200 (247)	
	25	1.7	2150 (57.6)	4400 (118)	6500 (174)	8150 (218)	10050 (269)	
	30	2.1	2700 (72.4)	5600 (150)	6700 (180)	10050 (269)	11250 (302)	
	40	2.8	3300 (88.4)	6900 (185)	7900 (212)	10300 (275)		
	45	3.1	3550 (95.1)	7000 (188)	8650 (232)	11000 (295)		
	50	3.5	4050 (109)	7800 (209)	9700 (260)	11000 (295)		
	60	4.1	4250 (114)	8200 (220)	9900 (265)	11450 (307)		
	80	5.5	5950 (159)	10000 (268)	11600 (311)			
	100	6.9	7450 (200)	11750 (315)	11900 (319)			
	125	8.6	8800 (236)	12200 (327)				
3 PSIG (0.21 BAR) 655-697-008  ±0.6 PSIG (0.041 BAR)	5	0.34	1100 (29.5)	1950 (52.3)	2800 (75.0)	4250 (114)	5400 (145)	7200 (193)
	10	0.69	1650 (44.2)	3100 (83.1)	4650 (125)	7750 (208)	8700 (233)	9100 (244)
	15	1.0	2050 (54.9)	4100 (110)	5950 (159)	9550 (256)	11150 (299)	11800 (316)
	20	1.4	2400 (64.3)	4900 (131)	7800 (209)	10650 (285)	12350 (331)	
	25	1.7	2600 (69.7)	5750 (154)	8700 (233)	11950 (320)	14050 (377)	
	30	2.1	3100 (83.1)	6550 (176)	10250 (275)	12050 (323)	14400 (386)	
	40	2.8	3150 (84.4)	7850 (210)	11300 (303)	13800 (370)		
	45	3.1	4150 (111)	8400 (225)	12450 (334)	14150 (379)		
	50	3.5	4400 (118)	9300 (249)	12450 (334)	14150 (379)		
	60	4.1	5000 (134)	10700 (287)	13000 (348)	15350 (411)		
	80	5.5	6400 (172)	13050 (350)	16000 (429)			
	100	6.9	7650 (205)	15400 (413)	16050 (430)			
	125	8.6	9200 (247)	16050 (430)				
3 PSIG (0.21 BAR) 655-697-008  ± 1% ABS ±0.18 psia (0.012 BAR)	5	0.34	500 (13.4)	1150 (30.8)	1200 (32.2)	1450 (38.9)	1550 (41.5)	2100 (56.3)
	10	0.69	900 (24.1)	1350 (36.2)	1500 (40.2)	2750 (73.7)	3200 (85.8)	3400 (91.1)
	15	1.0	1200 (32.2)	1700 (45.6)	2200 (58.9)	3900 (105)	4900 (131)	4950 (133)
	20	1.4	1500 (40.2)	2100 (56.3)	2900 (77.7)	5300 (142)	8000 (214)	
	25	1.7	1900 (50.9)	2600 (69.7)	4300 (115)	7400 (198)	9350 (251)	
	30	2.1	2200 (58.9)	3100 (83.1)	5100 (137)	8400 (225)	8650 (232) <sup>(1)</sup>	
	40	2.8	2900 (77.7)	4800 (129)	8000 (214)	8750 (235)		
	45	3.1	3300 (88.4)	5800 (155)	9300 (249)	9900 (265)		
	50	3.5	3700 (99.2)	6800 (182)	10200 (273)	10600 (284)		
	60	4.1	4400 (118)	8400 (225)	11600 (311)	10700 (287)		
	80	5.5	6300 (169)	10800 (289)	9400 (252) <sup>(1)</sup>			
	100	6.9	8100 (217)	12100 (324)	11750 (315)			
	125	8.6	10000 (268)	10750 (288) <sup>(1)</sup>				
3 PSIG (0.21 BAR) 655-697-008  ± 2% ABS ±0.35 psia (0.024 BAR)	5	0.34	900 (24.1)	1450 (38.9)	1800 (48.2)	3000 (80.4)	3000 (80.4)	4650 (125)
	10	0.69	1250 (33.5)	2050 (54.9)	3150 (84.4)	5150 (138)	6450 (173)	6650 (178)
	15	1.0	1800 (48.2)	3100 (83.1)	4400 (118)	7200 (193)	8700 (233)	8700 (233)
	20	1.4	2200 (58.9)	3800 (102)	6100 (163)	8600 (230)	11000 (295)	
	25	1.7	2600 (69.7)	5000 (134)	7600 (204)	9700 (260)	11050 (296)	
	30	2.1	2900 (77.7)	5800 (155)	8700 (233)	11200 (300)	11450 (3070)	
	40	2.8	3600 (96.5)	7800 (209)	10800 (289)	11600 (311)		
	45	3.1	4000 (107)	8400 (225)	11600 (311)	11600 (311)		
	50	3.5	4600 (123)	9400 (252)	12400 (332)	11750 (315)		
	60	4.1	5100 (137)	10600 (284)	13800 (370)	13250 (355)		
	80	5.5	6500 (174)	12700 (340)	12600 (338) <sup>(1)</sup>			
	100	6.9	8100 (217)	14400 (386)	12550 (336) <sup>(1)</sup>			
	125	8.6	10000 (268)	12500 (335) <sup>(1)</sup>				

1. Limited due to boost

 - Shaded areas show where maximum operating inlet pressure for a given port diameter is exceeded.

**P203 H Flow Capacities in SCFH** (Nm<sup>3</sup>/h) of 0.6 Specific Gravity Natural Gas



Outlet Pressure, Spring Part Number, and Accuracy	Inlet Pressure		NPT 2 (DN 50) Body Size					
			Orifice Size, Inches (mm)					
	PSIG	BAR	1/4 (6.4)	3/8 (9.5)	1/2 (13)	3/4 (19)	1 (25)	1-3/16 (30)
3 PSIG (0.21 BAR)  655-697-008  ±0.3 PSIG (0.021 BAR)	5	0.34	750 (20.1)	1400 (37.5)	1600 (42.9)	2400 (64.3)	2900 (77.7)	3500 (93.8)
	10	0.69	1200 (32.2)	1900 (50.9)	2750 (73.7)	5000 (134)	6400 (171)	6900 (185)
	15	1.0	1400 (37.5)	2000 (53.6)	3100 (83.1)	5900 (158)	7700 (206)	9800 (263)
	20	1.4	1850 (49.6)	3000 (80.4)	4150 (111)	7700 (206)	7900 (212)	
	25	1.7	2050 (54.9)	3900 (105)	5000 (134)	9100 (244)	9750 (261)	
	30	2.1	2550 (68.3)	4800 (129)	6700 (180)	10100 (271)	17200 (461)	
	40	2.8	3150 (84.4)	6250 (168)	8700 (233)	11600 (311)		
	45	3.1	3400 (91.1)	6750 (181)	9900 (265)	14500 (389)		
	50	3.5	3900 (105)	6750 (181)	12300 (330)	13900 (373)		
	60	4.1	4350 (117)	9400 (252)	12700 (340)	18300 (490)		
	80	5.5	5600 (150)	12700 (340)	18800 (504)			
	100	6.9	7000 (188)	14800 (397)	18800 (504)			
	125	8.6	8650 (232)	18800 (504)				
3 PSIG (0.21 BAR)  655-697-008  ±0.6 PSIG (0.041 BAR)	5	0.34	1100 (29.5)	1950 (52.3)	2550 (68.3)	4700 (126)	6000 (161)	7450 (200)
	10	0.69	1550 (41.5)	3000 (80.4)	4750 (127)	8600 (230)	12200 (327)	15400 (413)
	15	1.0	2050 (54.9)	3850 (103)	5950 (159)	12500 (338)	16200 (434)	20300 (544)
	20	1.4	2400 (64.3)	4850 (130)	8200 (220)	17000 (456)	21800 (584)	
	25	1.7	2800 (75.0)	5750 (154)	9800 (263)	19700 (528)	23000 (616)	
	30	2.1	3150 (84.4)	6450 (173)	11600 (311)	22500 (603)	26500 (710)	
	40	2.8	3650 (97.8)	7850 (210)	14300 (383)	26400 (708)		
	45	3.1	4100 (110)	8900 (239)	15500 (415)	28500 (764)		
	50	3.5	4350 (117)	9450 (253)	17000 (456)	29600 (793)		
	60	4.1	5100 (137)	11100 (297)	19850 (532)	29900 (801)		
	80	5.5	6350 (170)	14350 (385)	25200 (675)			
	100	6.9	7250 (194)	17250 (462)	29400 (788)			
	125	8.6	9400 (252)	21000 (563)				
3 PSIG (0.21 BAR)  655-697-008  ± 1% ABS ±0.18 psia (0.012 BAR)	5	0.34	650 (17.4)	1100 (29.3)	790 (21.2)	1500 (40.2)	1700 (45.6)	1750 (46.9)
	10	0.69	1000 (26.8)	1250 (33.5)	1500 (40.2)	2500 (67.0)	3700 (99.2)	4300 (115)
	15	1.0	1250 (33.5)	1750 (46.9)	2000 (53.6)	2900 (77.7)	3750 (101)	6000 (161)
	20	1.4	1450 (38.9)	2400 (64.3)	2200 (58.9)	4100 (110)	5750 (154)	
	25	1.7	1600 (42.8)	2900 (77.7)	4000 (107)	6900 (185)	6400 (172)	
	30	2.1	1950 (52.3)	3550 (95.1)	4400 (118)	8700 (233)	6700 (180)	
	40	2.8	2700 (72.4)	3850 (103)	5500 (147)	6450 (173)		
	45	3.1	2900 (77.7)	5400 (145)	9000 (241)	8000 (214)		
	50	3.5	3300 (88.4)	5700 (153)	9100 (244)	7900 (212)		
	60	4.1	3900 (105)	7200 (193)	11500 (308)	10300 (276)		
	80	5.5	5250 (141)	9200 (247)	9800 (263) <sup>(1)</sup>			
	100	6.9	6250 (168)	11300 (303)	10900 (292) <sup>(1)</sup>			
	125	8.6	7750 (208)	12650 (339)				
3 PSIG (0.21 BAR)  655-697-008  ± 2% ABS ±0.35 psia (0.024 BAR)	5	0.34	800 (21.4)	1450 (38.9)	1700 (45.6)	3150 (84.4)	3250 (87.1)	4000 (107)
	10	0.69	1300 (34.8)	2150 (57.6)	3200 (85.8)	5550 (149)	7200 (193)	9000 (241)
	15	1.0	1550 (41.5)	2850 (76.4)	4050 (109)	6800 (182)	8250 (221)	10800 (289)
	20	1.4	1850 (49.6)	3300 (88.4)	5400 (145)	9300 (249)	10900 (292)	
	25	1.7	2350 (62.9)	4650 (125)	6700 (180)	11250 (302)	15600 (418)	
	30	2.1	2450 (65.7)	5100 (137)	8600 (230)	12250 (328)	17350 (465)	
	40	2.8	3150 (84.4)	6950 (186)	11400 (306)	15150 (406)		
	45	3.1	3400 (91.1)	7650 (205)	11900 (319)	18150 (486)		
	50	3.5	3800 (102)	8500 (228)	14000 (375)	20200 (541)		
	60	4.1	4300 (115)	9850 (264)	19000 (509)	21150 (567)		
	80	5.5	5500 (147)	12600 (338)	23100 (619)			
	100	6.9	6500 (174)	15500 (415)	23650 (634)			
	125	8.6	8100 (217)	20650 (553)				

1. Limited due to boost

- Shaded areas show where maximum operating inlet pressure for a given port diameter is exceeded.

## P203 P Flow Capacities in SCFH (Nm<sup>3</sup>/h) of 0.6 Specific Gravity Natural Gas

Outlet Pressure, Spring Part Number, and Accuracy	Inlet Pressure		NPT 1-1/2 Body Size					
			Orifice Size, Inches (mm)					
	PSIG	BAR	1/4 (6.4)	3/8 (9.5)	1/2 (13)	3/4 (19)	1 (25)	1-3/16 (30)
6 inches w.c. (15 mbar)  655-697-003  ±1 inch w.c. 2.5 mbar	0.4	0.028				1200 (32.2)	1500 (40.2)	1750 (46.9)
	0.5	0.034				1600 (42.9)	1900 (50.9)	2200 (59.0)
	1	0.07	400 (10.7)	900 (42.1)	1300 (34.8)	2300 (61.6)	2900 (77.7)	3300 (88.4)
	1.5	0.10	500 (13.4)	1150 (30.8)	1650 (44.2)	3000 (80.4)	3600 (96.5)	4300 (115)
	2	0.14	600 (16.1)	1400 (37.5)	2000 (53.6)	3500 (93.8)	4200 (113)	5500 (147)
	5	0.34	1000 (26.8)	2300 (61.6)	3500 (93.8)	5700 (153)	7300 (196)	7700 (206)
	13	0.90	1650 (44.2)	3700 (99.2)	6200 (166)	10,000 (268)	13,500 (362)	13,500 (362)
	25	1.7	2400 (64.3)	5200 (139)	9000 (241)	13,500 (362)	13,500 (362)	
	60	4.1	4400 (118)	9600 (257)	13,500 (362)	13,500 (362)		
	100	6.9	7000 (188)	13,500 (362)	13,500 (362)			
125	8.6	7000 (188)	13,500 (362)					
7 inches w.c. (17 mbar)  655-697-004  ± 1 inch w.c. 2 inches mbar	0.4	0.028				950 (25.5)	1350 (36.2)	1550 (41.5)
	0.5	0.034				1500 (40.2)	1700 (45.6)	1950 (52.3)
	1	0.07	400 (10.7)	800 (21.4)	1200 (52.2)	2000 (53.6)	2600 (85.8)	3000 (80.4)
	1.5	0.10	500 (13.4)	1050 (28.1)	1500 (40.2)	2550 (68.3)	3200 (85.8)	4100 (110)
	2	0.14	600 (16.1)	1300 (34.8)	1800 (48.2)	3000 (80.4)	3700 (99.2)	5000 (134)
	5	0.34	1000 (26.8)	2100 (56.3)	3100 (83.1)	5000 (134)	6500 (174)	7000 (188)
	13	0.90	1650 (44.2)	3300 (88.4)	5500 (147)	8600 (230)	12,000 (322)	13,500 (362)
	25	1.7	2400 (64.3)	5000 (134)	8000 (214)	13,500 (362)	13,500 (362)	
	60	4.1	4400 (118)	9400 (252)	13,500 (362)	13,500 (362)		
	100	6.9	7000 (188)	13,500 (362)	13,500 (362)			
125	8.6	7000 (188)	13,500 (362)					
11 inches w.c. (27 mbar)  655-697-005  ± 2 inches w.c. (5 mbar)	0.5	0.03				1450 (38.9)	1650 (44.2)	1850 (49.8)
	1	0.07	375 (10.1)	750 (20.1)	1100 (29.5)	1800 (48.2)	2500 (67.0)	2900 (77.7)
	1.5	0.10	475 (12.7)	1000 (26.8)	1450 (38.9)	2400 (64.3)	3100 (83.1)	3900 (105)
	2	0.14	550 (14.7)	1250 (33.5)	1700 (45.6)	3000 (80.4)	3600 (96.5)	4800 (129)
	5	0.34	950 (25.5)	2000 (53.6)	2900 (77.7)	4800 (129)	6500 (174)	6700 (180)
	13	0.90	1550 (41.5)	3100 (83.1)	5100 (137)	9000 (241)	11,000 (295)	13,500 (362)
	25	1.7	2260 (60.6)	4700 (126)	8000 (214)	13,500 (362)	13,500 (362)	
	60	4.1	4200 (113)	8900 (239)	13,500 (362)	13,500 (362)		
	100	6.9	6600 (177)	13,500 (362)	13,500 (362)			
	125	8.6	6600 (177)	13,500 (362)				
20 inches w.c. (50 mbar)  655-697-006  ± 3 inches w.c. (7 mbar)	1	0.07	300 (8.04)	500 (13.4)	950 (25.5)	1000 (26.8)	1300 (34.8)	2000 (53.6)
	2	0.14	500 (13.4)	950 (24.5)	1500 (40.2)	2000 (53.6)	2900 (77.7)	4000 (107)
	5	0.34	850 (22.8)	1700 (45.6)	2400 (64.3)	4000 (107)	5000 (134)	5300 (142)
	13	0.90	1350 (36.2)	2800 (75.0)	4400 (118)	6500 (174)	8700 (233)	13,500 (362)
	25	1.7	2000 (53.6)	4800 (129)	6600 (177)	10,000 (268)	13,500 (362)	
	60	4.1	3700 (99.2)	9000 (241)	12,700 (340)	13,500 (362)		
	100	6.9	6000 (161)	13,500 (362)	13,500 (362)			
	125	8.6	6000 (161)	13,500 (362)				
1 PSIG 0.069 BAR  655-697-007  ±0.2 PSIG 0.014 BAR	2.0	0.14	500 (13.4)	750 (20.1)	1100 (29.5)	1400 (37.5)	2400 (64.3)	3000 (80.4)
	6.0	0.41	1100 (29.5)	1800 (48.2)	2500 (67.0)	4000 (107)	5200 (139)	7000 (188)
	14	0.97	1500 (40.5)	3000 (80.4)	4500 (121)	7000 (188)	9000 (241)	13,500 (362)
	30	2.1	2300 (61.6)	4800 (129)	7000 (188)	11,000 (295)	13,500 (362)	
	60	4.1	4400 (118)	9200 (247)	10,500 (281)	13,500 (362)		
	100	6.9	7000 (188)	13,500 (362)	13,500 (362)			
	125	8.6	7000 (188)	13,500 (362)				
3 PSIG 0.069 BAR  655-697-008  ±0.6 PSIG 0.041 BAR	3.0	0.21	500 (13.4)	1000 (26.8)	1500 (40.2)	2000 (53.6)	3200 (85.8)	3600 (96.5)
	7.0	0.48	1000 (26.8)	2200 (59.0)	3400 (91.1)	5700 (152)	7000 (188)	8800 (236)
	14	0.97	1500 (40.2)	3000 (80.4)	5700 (153)	10,000 (268)	11,000 (295)	13,500 (362)
	30	2.1	2400 (63.3)	5000 (134)	7500 (201)	13,500 (362)	13,500 (362)	
	60	4.1	4300 (115)	9400 (252)	11,500 (308)	13,500 (362)		
	100	6.9	6800 (182)	11,400 (306)	13,500 (362)			
125	8.6	6800 (182)	11,400 (306)					

1. Limited due to boost

 - Shaded areas show where indicated droop would be exceeded regardless of capacity.

 - Shaded areas show where maximum operating inlet pressure for a given port diameter is exceeded.

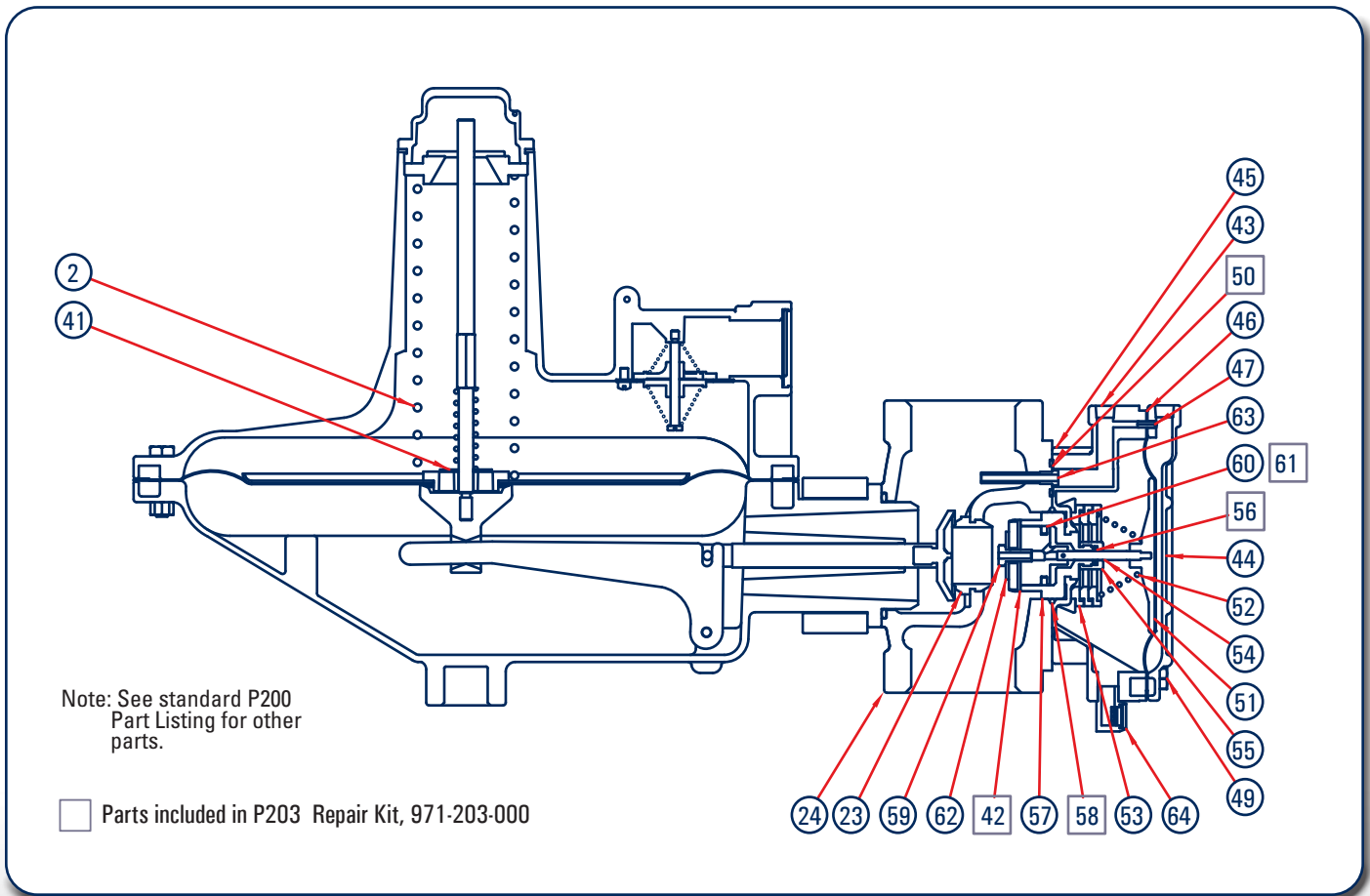

**P203 Body Positions**

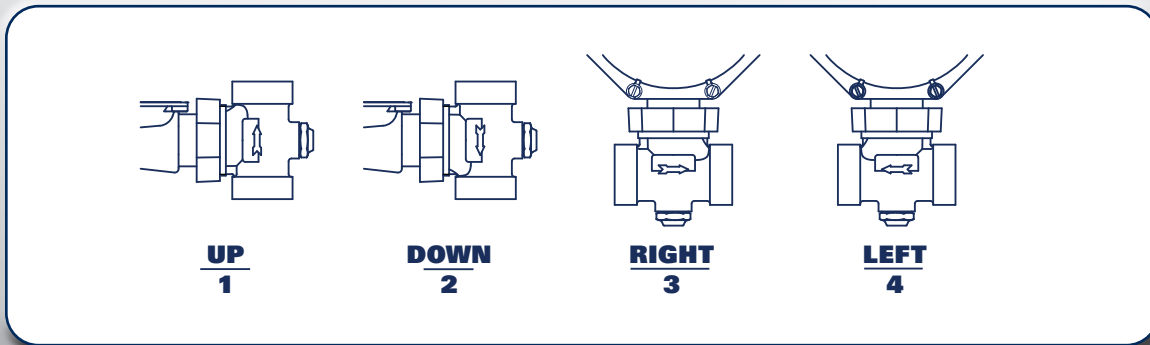

**P203 Vent Positions**

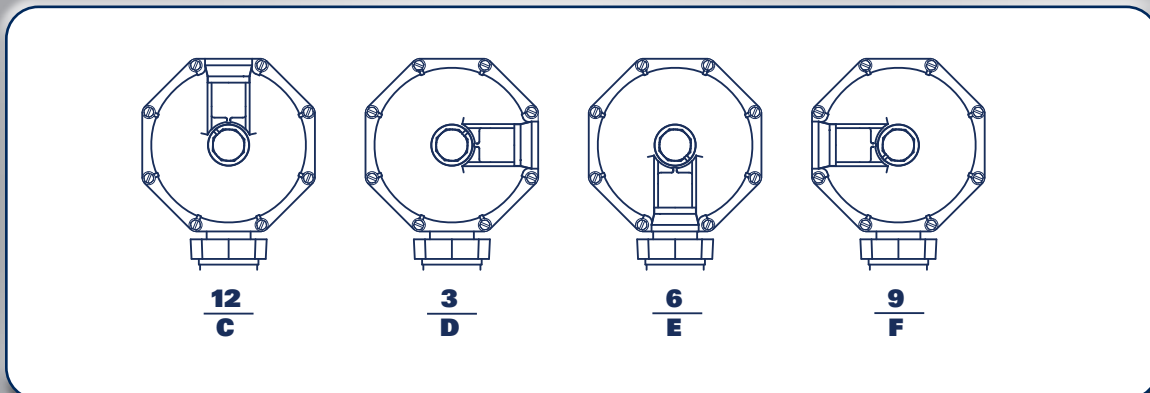

Item	Description	Qty.	Part Number
2	<b>Range Spring - Normal (0)</b>	1	See Table
	Brown, Plated Steel	1	655-697-002
	Red Plated Steel	1	655-697-003
	Black, Plated Steel	1	655-697-004
	Gray, Plated Steel	1	655-697-005
	Dark Green, Plated Steel	1	655-697-006
	<b>Range Spring - High (H)</b>		
Dark Blue, Plated Steel	1	655-697-007	
Orange, Plated Steel	1	655-697-008	
23	<b>Orifices</b>		
	1/4" Aluminum	1	688-061-000
	3/8" Aluminum	1	688-061-001
	1/2" Aluminum	1	688-061-002
	3/4" Aluminum	1	688-061-003
	1" Aluminum	1	688-061-004
24	<b>Body</b>		
	Iron 1.5" NPT	1	664-396-000
	Iron 1.5" x 2" NPT	1	664-396-001
	Iron 2" NPT	1	664-384-000
	Iron 2" , 125 FF	1	664-385-000
<b>P203 Monitor Parts Only - See P200 for other Parts</b>			
41	Relief Restriction	1	662-237-000
42	Disk Holder Assembly	1	822-044-000
43	Pipe Plug	2	639-000-054
44	Monitor Spring Case	1	604-264-000
45	Monitor Lower Case	1	629-237-000
46	Diaphragm	1	618-101-000
47	Roll Pin	1	635-074-000
48	Cap Screw	4	648-466-009
<b>P203 Monitor Parts Only - See P200 for other Parts</b>			
49	Cap Screw	8	648-466-000
50	O-ring	1	649-000-185
51	Diaphragm Plate	1	638-079-000
52	<b>Monitor Springs</b>		
	Green Spring (See Monitor Data Table)	1	655-746-000
	Red Spring (See Monitor Data Table)	1	655-746-001
	Blue Spring (See Monitor Data Table)	1	655-746-002
	Silver Spring (See Monitor Data Table)	1	655-746-003
53	Lower Spring Seat (See Monitor Data Table)	0-3	650-178-000
54	Piston Assembly	1	809-237-000
55	O-ring Retainer	1	643-206-000
56	Piston Assembly O-ring	1	649-000-001
57	Piston Guide	1	626-112-000
58	Piston Guide O-ring	1	649-309-003
59	Disk Holder Screw	1	648-545-000
60	Piston Ring Expander	1	644-062-000
61	Piston Ring	1	644-063-000
62	Washer	1	662-236-002
63	Pilot Tube	1	660-082-000
64	Vent Assembly	1	836-004-001
65	Sealing Screw (P203P only)	1	645-544-000
66	Stabilizer Gasket (P203S only)	1	624-088-000
67	Stabilizer Frame (P203S only)	1	704-008-000
68	Stabilizer Snap Ring (P203S only)	1	693-028-000

Item	Description	Qty.	Part Number
69	Stabilizer Neck (P203S only)	1	608-084-000

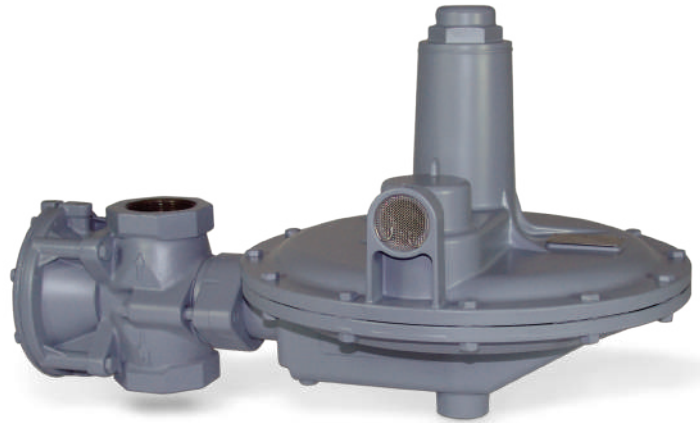

# P212 Pressure Regulator

- Minimize Sudden Downstream Load Change
- Wide Pressure Ranges
- Full Relief Valve

The BelGAS P212 gas pressure regulator is a direct operating, spring loaded adjustable regulator, used in applications where pressure reduction is required.

The P212 is built on the reliable and time proven P202 platform and has been enhanced to offer a full relieving regulator through the diaphragm relief device. When used with a 2.5" bonnet vent port, the P212 becomes a fully relieving pressure regulator.

Available in pressure ranges from 2" of water column up to 5 PSIG, making them ideal for use in applications where wide variations in pressure reduction are also required. The BelGAS Type P212 is offered with choice of ductile cast iron or WCB steel body, flanged or threaded.



## Applications

- Compressors
- Gas Engines
- Service Regulators

## Materials of Construction

Adjusting Screw	Aluminum
Body	Ductile Iron or WCB Steel
Bonnet	Aluminum
Closing Cap	Aluminum
Diaphragm	Nitrile
Lower Casing	Aluminum
Molded Seat Assembly	Nitrile
Orifice	Aluminum
Flange	Ductile Iron / WCB Steel

## Specifications

Maximum Inlet	See Table 1	
Maximum Emergency Outlet	15 PSIG	
Pressure Ranges	See Table 2	
Port Sizes	1.25 NPT	
	1.5 NPT	
	1.5 NPT x 2 NPT	
	2 NPT	
Orifice Sizes	1/4"	
	3/8"	
	1/2"	
	3/4"	
	1"	
	1-3/16"	
	NPT	
End Connections	150 RF Flange	Steel Units Only
	125 FF Flange	Iron Units Only

## P212 Series Maximum Inlet Pressure

Orifice Inches	Range	Maximum Inlet Pressure	
		PSIG	BAR
1/4"	Any	125	8.618
3/8"	Any	125	8.618
1/2"	Any	100	6.894
3/4"	Any	60	4.136
1"	2-4.5" thru 14-30" WC	25	1.723
	1-2 thru 2-5 PSIG	30	2.068
1-3/16"	2-4.5" thru 14-30" WC	13	0.896
	1-2 thru 1.5-3.25 PSIG	14	0.965
	2-5 PSIG	20	1.378

## P212 Series Range Springs

Model	Spring Ranges		Spring Color	Part Number
	W.C. or PSI	Bar		
P212L	2 - 4.5 WC	0.005 - 0.011	Brown	655-697-002
	3.5- 6.5 WC	0.009 -0.016	Red	655.697-003
	5 - 9 WC	0.012 - 0.022	Black	655-697-004
	6 - 14 WC	0.015 - 0.035	Purple	655-697-011
	8.5 - 18 WC	0.021 - 0.045	White	655-697-005
	14 - 30 WC	0.035 - 0.075	Dark Green	655-697-006
	1 - 2 PSIG	0.069 - 0.138	Dark Blue	655-697-007
P212H	1.5 - 3.25 PSIG	0.103 - 0.224	Orange	655-697-008
	2 - 5 PSIG	0.138 - 0.345	Yellow	655-697-009

## P212 Regulator Rebuild Kits

	Kit Includes	Part Number
P212L & P212H Ranges	Diaphragm, disk holder assembly, cap gasket and body/lower casing o-ring	971-212-000

## P212 Part Matrix

P212									
									Configuration
	<b>L</b>								Normal
	<b>H</b>								High
									Port Size
		<b>12</b>							1.25 NPT
		<b>14</b>							1.5 NPT
		<b>15</b>							1.5 x 2 NPT
		<b>16</b>							2 NPT
									Spring Range - WC or PSI / mBAR
		<b>004</b>							2 - 4.5" WC    4.98 - 11.20
		<b>006</b>							3.5 - 6.5" WC    8.71 - 16.19
		<b>009</b>	<b>L Version Only</b>						5 - 9" WC    12.45 - 22.41
		<b>014</b>	<b>L Version Only</b>						6 - 14" WC    14.94 - 34.87
		<b>018</b>							8.5 - 18" WC    21.17 - 44.83
		<b>030</b>							14 - 30" WC    34.87 - 74.72
		<b>002</b>							1 - 2 PSIG    68.94 - 137.89
		<b>003</b>	<b>H Version Only</b>						1.5 - 3.25 PSIG    103.42 - 224.07
		<b>005</b>	<b>H Version Only</b>						2 - 5 PSIG    137.89 - 344.73
									Special Construction
		<b>0</b>							None
		<b>A</b>							150 RF (2" Steel Only)
		<b>E</b>							125 FF (2" Iron Only)
									Orifice
		<b>4</b>							1/4"
		<b>6</b>							3/8"
		<b>8</b>							1/2"
		<b>B</b>							3/4"
		<b>D</b>							1"
		<b>F</b>							1-3/16"
									Port Orientation
		<b>1</b>							Up (Standard)
		<b>2</b>							Down
		<b>3</b>							Right
		<b>4</b>							Left
									Bonnet Orientation
		<b>C</b>							12 O'Clock
		<b>D</b>							3 O'Clock (Standard)
		<b>E</b>							6 O'Clock
		<b>F</b>							9 O'Clock
									Body Material
		<b>0</b>							Iron
		<b>2</b>							Steel

## P212 Dimensions

Body Size	A			B	C	D		
	Inches	NPT	125 FF Flange			150 RF Flange	NPT	125 FF Flange
1.25	6.13			11.03	18.09	1.85		
1.5	6.13		10	11.03	18.09	1.85		1.85
1.5 x 2	6.13			11.03	18.09	1.85		

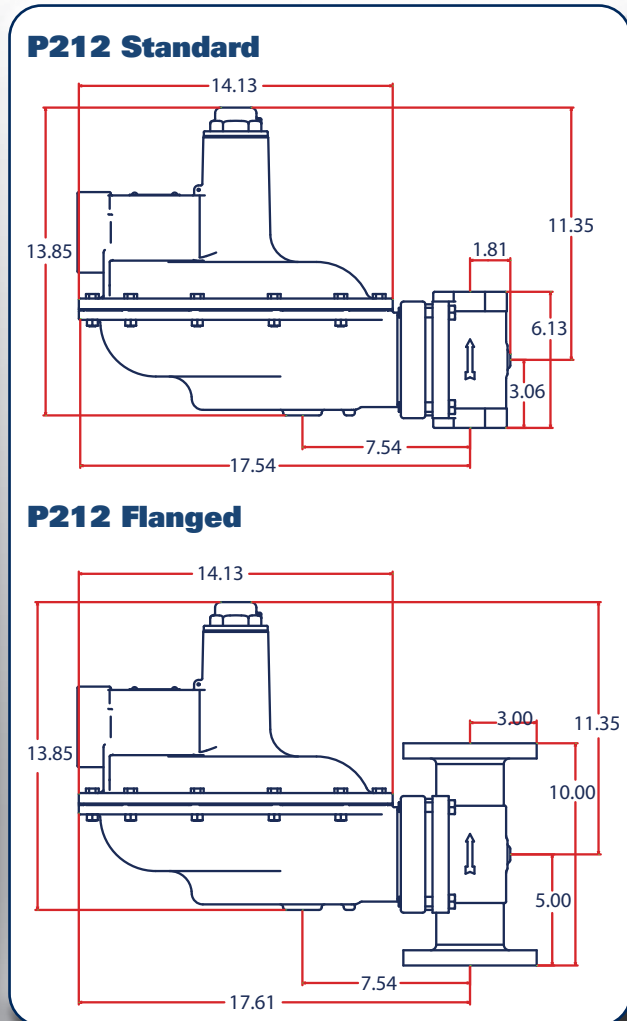

## P212 Head Only

P212				
	↑	↑	↑	Configuration
<b>L</b>				Normal
<b>H</b>				High
				Spring Range - WC or PSIG / mBAR
<b>004</b>				2 - 4.5" WC      4.98 - 11.20
<b>006</b>	<b>L Ver- sion Only</b>			3.5 - 6.5" WC      8.71 - 16.19
<b>009</b>				5 - 9" WC      12.45 - 22.41
<b>014</b>				6 - 14" WC      14.94 - 34.87
<b>018</b>				8.5 - 18" WC      21.17 - 44.83
<b>030</b>				14 - 30" WC      34.87 - 74.72
<b>002</b>	<b>H Ver- sion Only</b>			1 - 2 PSIG      68.94 - 137.89
<b>003</b>				1.5 - 3.25 PSIG      103.42 - 224.07
<b>005</b>				2 - 5 PSIG      137.89 - 344.73
				Special Construction
<b>0</b>				None
				Bonnet Orientation
<b>C</b>				12 O'Clock
<b>D</b>				3 O'Clock (Standard)
<b>E</b>				6 O'Clock
<b>F</b>				9 O'Clock

## P212 Vent Orientation

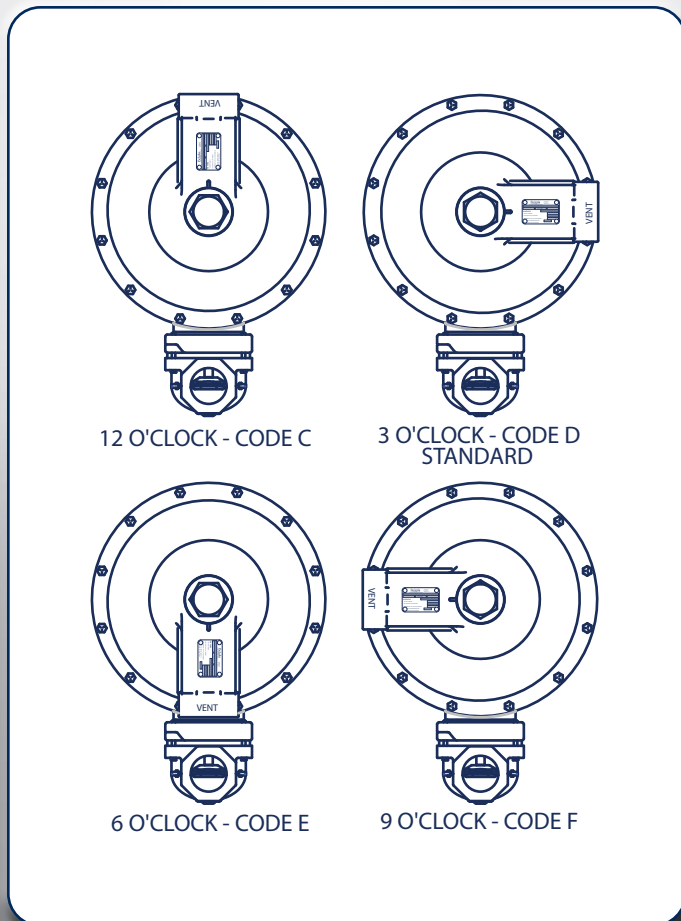

## P212 Body Positions

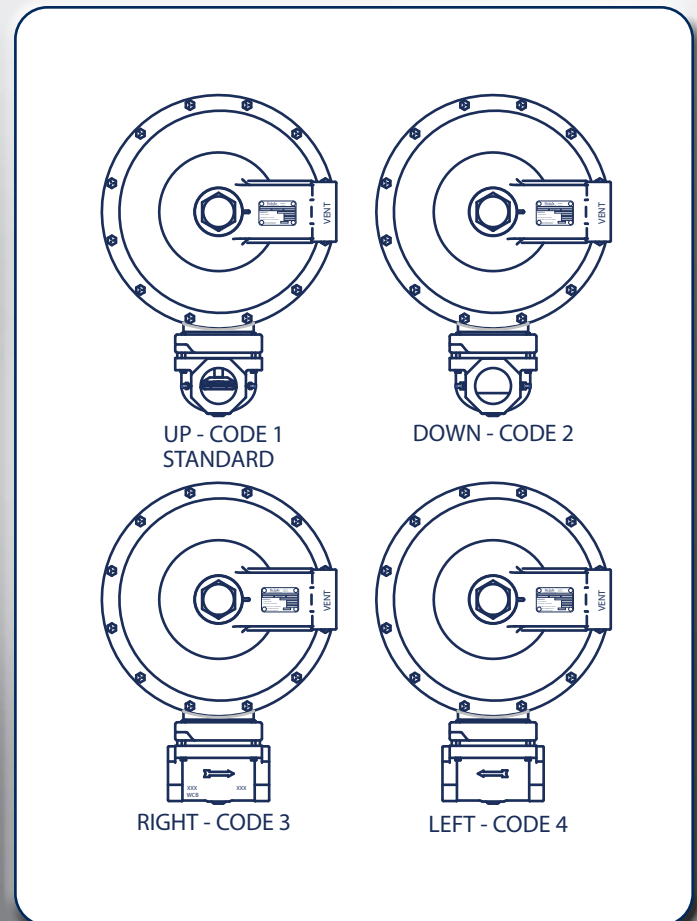

**P212 Normal (L) Relief Capacities**

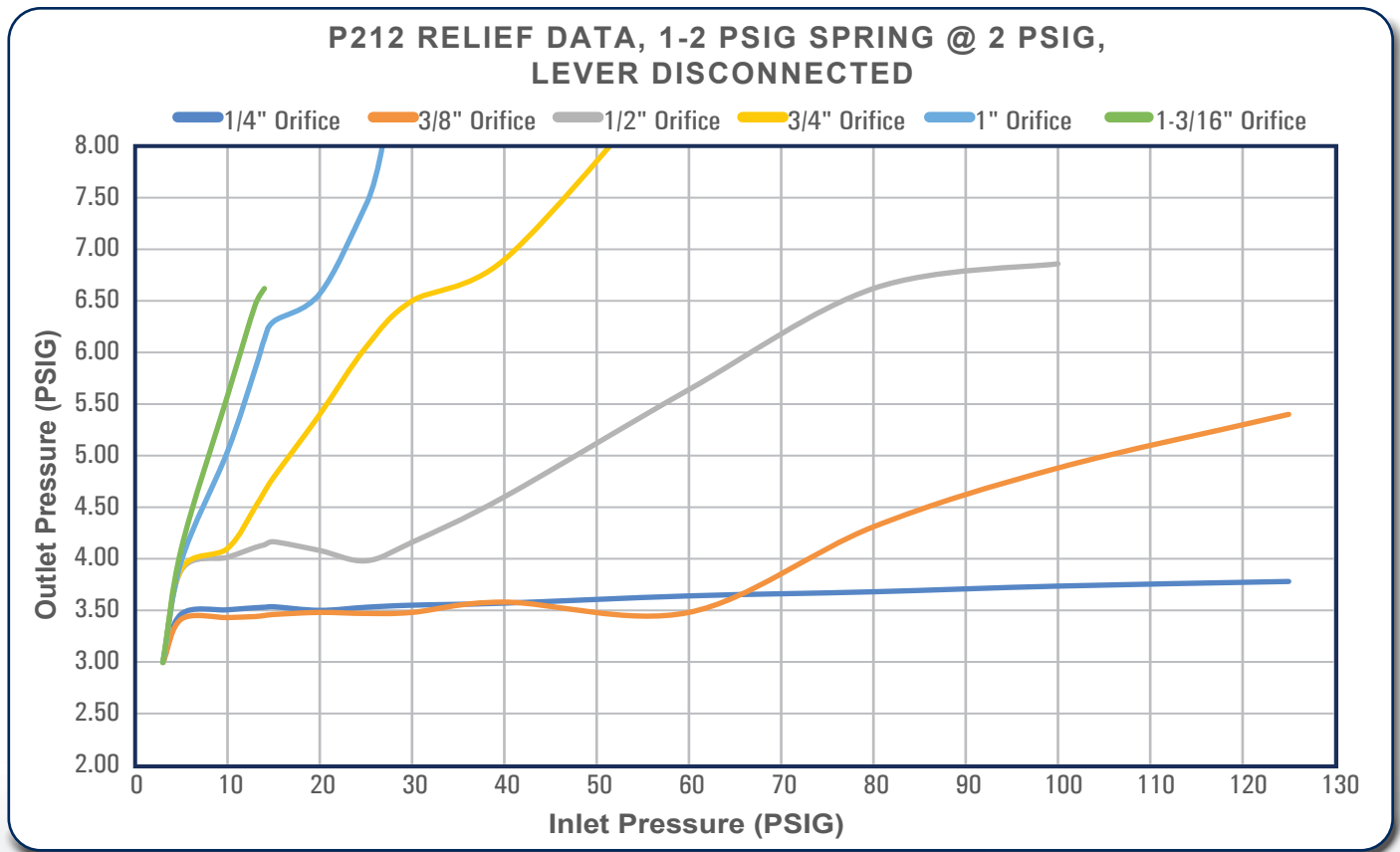

**P212 High (H) Relief Capacities**

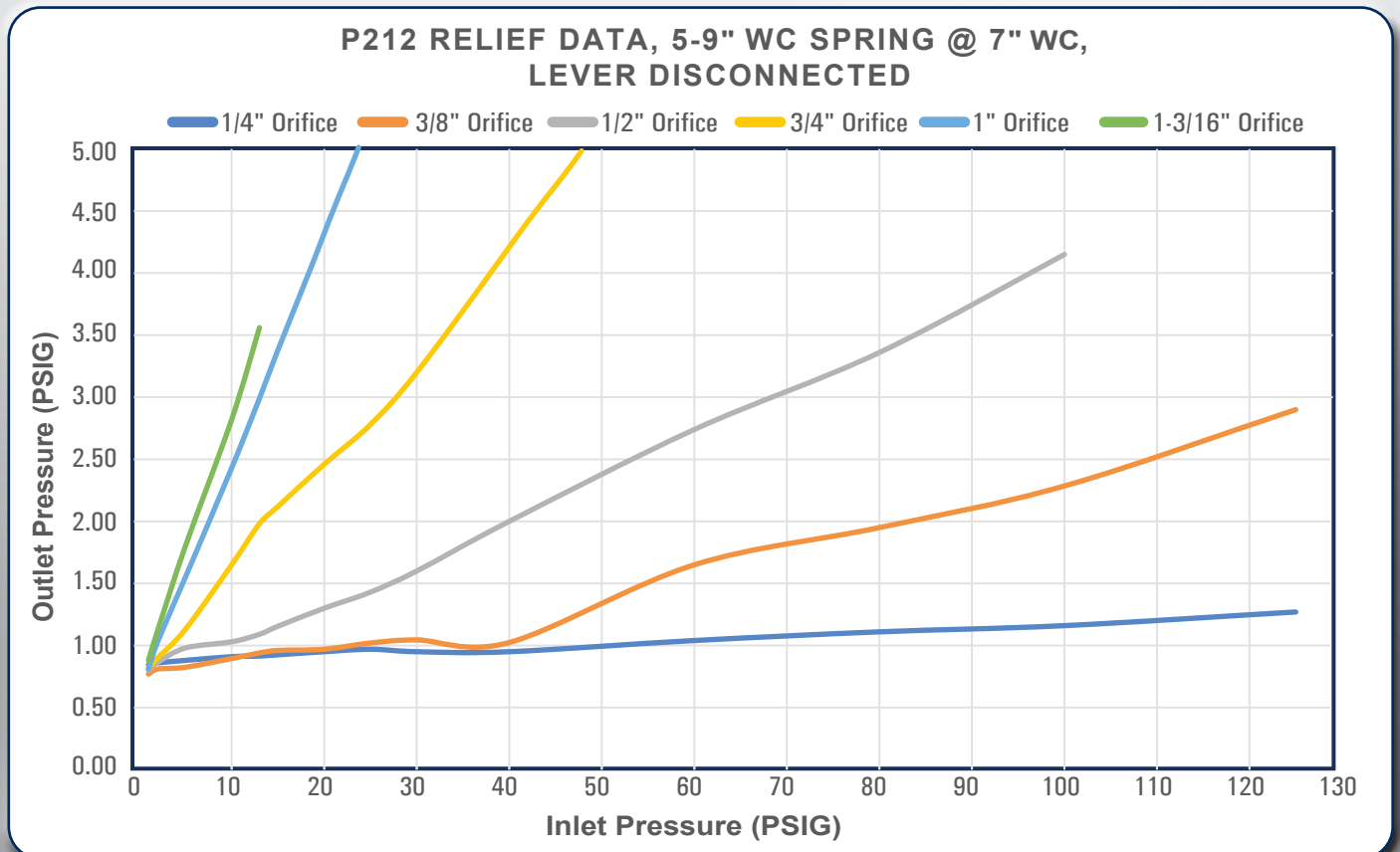

**P212 Flow Capacities in SCFH** (Nm<sup>3</sup>/h) of 0.6 Specific Gravity Natural Gas

Outlet Pressure, Spring Part Number, and Accuracy	Inlet Pressure		NPT 1-1/2 Body Size					
			Orifice Size, Inches (mm)					
	PSIG	BAR	1/4 (6.4)	3/8 (9.5)	1/2 (13)	3/4 (19)	1 (25)	1-3/16 (30)
4 inches w.c. (10 mbar) 655-697-002 or 655-697-003 1 inch w.c. (2 mbar) droop 2 inches w.c. (5 mbar) boost	0.4	0.028				1000 (26.8)	1400 (37.5)	1600 (42.8)
	0.5	0.034				1400 (37.5)	1600 (42.8)	1800 (48.2)
	1	0.07	400 (10.7)	800 (21.4)	1200 (32.2)	2100 (56.3)	2500 (67.0)	2700 (72.4)
	1.5	0.10	500 (13.4)	1050 (28.1)	1600 (42.9)	2500 (67.0)	3000 (80.4)	3200 (85.8)
	2	0.14	600 (16.1)	1300 (34.8)	2100 (56.3)	2800 (75.0)	3500 (93.8)	3800 (102)
	5	0.34	1150 (30.8)	2200 (58.9)	3300 (88.4)	4500 (121)	5300 (142)	6000 (161)
	13	0.90	1600 (42.8)	3600 (96.4)	6200 (166)	7000 (188)	6000 (161)	6850 (184)
	25	1.7	2550 (68.3)	5000 (134)	7350 (197)	8950 (240)	9000 (241)	
	60	4.1	4750 (127)	5100 (137)	7050 (189)	5600 (150) <sup>(1)</sup>		
	100	6.9	6650 (186)	7300 (196)	5200 (139) <sup>(1)</sup>			
125	8.6	6950 ( )	8300 (222)					
7 inches w.c. (17 mbar) 655-697-004 1 inch w.c. (2 mbar) droop 2 inches w.c. (5 mbar) boost	0.4	0.028				900 (24.1)	1300 (34.8)	1450 (38.9)
	0.5	0.034				1200 (32.2)	1550 (41.5)	1750 (46.9)
	1	0.07	400 (10.7)	800 (21.4)	1100 (29.5)	1900 (50.9)	2300 (61.6)	2500 (67.0)
	1.5	0.10	500 (13.4)	1050 (28.1)	1500 (40.2)	2300 (61.6)	2800 (75.0)	1800 (48.2)
	2	0.14	600 (16.1)	1300 (34.8)	1900 (50.9)	2100 (56.3)	3300 (88.4)	1800 (48.2)
	5	0.34	950 (25.5)	2100 (56.3)	3200 (85.8)	3350 (89.8)	5100 (137)	4500 (121)
	13	0.90	1600 (42.8)	2200 (58.9)	3300 (88.4)	5800 (155)	8000 (214)	8000 (214)
	25	1.7	2200 (58.9)	5200 (139)	6800 (182)	8400 (225)	8750 (235)	
	60	4.1	4300 (115)	9200 (247)	10100 (271)	9900 (265)		
	100	6.9	7500 (201)	10500 (281)	9200 (247) <sup>(1)</sup>			
125	8.6	9050 (243)	9800 (263) <sup>(1)</sup>					
11 inches w.c. (27 mbar) 655-697-005 ± 2 inches w.c. (5 mbar)	0.5	0.03				800 (21.4)	1500 (40.2)	1700 (45.6)
	1	0.07	400 (10.7)	700 (18.7)	1100 (29.5)	1800 (48.2)	2200 (58.9)	2450 (65.7)
	1.5	0.10	500 (13.4)	950 (25.5)	1450 (38.9)	2300 (61.6)	2800 (75.0)	2600 (69.7)
	2	0.14	600 (16.1)	1200 (32.2)	1700 (45.6)	1950 (52.3)	3200 (85.8)	2750 (73.7)
	5	0.34	950 (25.5)	2000 (53.6)	2900 (77.7)	3800 (102)	5100 (137)	5150 (138)
	13	0.90	1600 (42.8)	3400 (91.1)	3700 (99.2)	6100 (163)	7250 (194)	7650 (205)
	25	1.7	2100 (56.3)	5150 (138)	7100 (190)	7950 (213)	9400 (252)	
	60	4.1	4400 (118)	9250 (248)	9400 (252)	10400 (279)		
	100	6.9	7300 (196)	10000 (268)	10100 (271)			
	125	8.6	9050 (243)	10800 (289)				
14 inches w.c. (35 mbar) 655-697-005 ± 2 inches w.c. (5 mbar)	1	0.07	450 (12.1)	800 (21.4)	1000 (26.8)	1250 (33.5)	1500 (40.2)	1950 (52.3)
	1.5	0.10	500 (13.4)	850 (22.8)	1050 (28.1)	1550 (41.5)	1650 (44.2)	2350 (62.9)
	2	0.14	550 (14.7)	1150 (30.8)	1400 (37.5)	1750 (46.9)	2300 (61.6)	2500 (67.0)
	5	0.34	1000 (26.8)	1200 (32.2)	2050 (54.9)	3000 (80.4)	4300 (115)	4750 (127)
	13	0.90	1750 (46.9)	3050 (81.7)	4250 (114)	6100 (163)	7300 (196)	7850 (210)
	25	1.7	2500 (67.0)	4750 (127)	5650 (151)	8700 (233)	8700 (233)	
	60	4.1	4750 (127)	9450 (253)	9950 (267)	10550 (283)		
	100	6.9	7450 (200)	10400 (279)	10600 (284)			
	125	8.6	9050 (243)	10450 (280)				
	20 inches w.c. (50 mbar) 655-697-006 ± 3 inches w.c. (7 mbar)	1	0.07	300 (8.04)	500 (13.4)	750 (20.1)	1000 (26.8)	1300 (34.8)
2		0.14	500 (13.4)	950 (25.5)	1400 (37.5)	2000 (53.6)	2800 (75.0)	3100 (83.1)
5		0.34	900 (24.1)	1700 (45.6)	2500 (67.0)	4200 (113)	5000 (134)	5500 (147)
13		0.90	1500 (40.2)	3200 (85.8)	5400 (145)	6500 (174)	7000 (188)	7100 (190)
25		1.7	2100 (56.3)	4700 (126)	7000 (188)	8250 (221)	9350 (251)	
60		4.1	4750 (127)	8900 (239)	9950 (267)	10600 (284)		
100		6.9	7400 (198)	10500 (281)	10800 (289)			
125		8.6	9200 (247)	10950 (293)				

1. Limited due to boost

- Shaded areas show where indicated droop would be exceeded regardless of capacity.
- Shaded areas show where maximum operating inlet pressure for a given port diameter is exceeded.

**P212 Flow Capacities in SCFH** (Nm<sup>3</sup>/h) of 0.6 Specific Gravity Natural Gas



Outlet Pressure, Spring Part Number, and Accuracy	Inlet Pressure		NPT 2 (DN 50) Body Size					
			Orifice Size, Inches (mm)					
	PSIG	BAR	1/4 (6.4)	3/8 (9.5)	1/2 (13)	3/4 (19)	1 (25)	1-3/16 (30)
4 inches w.c. (10 mbar) 655-697-002 or 655-697-003 1 inch w.c. (2 mbar) droop 2 inches w.c. (5 mbar) boost	0.4	0.028				1200 (32.3)	1600 (42.8)	1800 (48.2)
	0.5	0.034				1700 (45.6)	2200 (58.9)	2400 (64.3)
	1	0.07	400 (10.7)	900 (24.1)	1300 (34.8)	2800 (75.0)	3200 (85.8)	3800 (102)
	1.5	0.10	500 (13.4)	1100 (29.5)	1700 (45.5)	3600 (96.5)	4300 (115)	5000 (134)
	2	0.14	600 (16.1)	1400 (37.5)	2200 (58.9)	4500 (121)	5500 (147)	6400 (172)
	5	0.34	1000 (26.8)	2300 (61.6)	3700 (99.2)	7800 (209)	9500 (255)	12700 (340)
	13	0.90	1650 (44.2)	3700 (99.2)	6500 (174)	13000 (348)	14000 (375)	14500 (389)
	25	1.7	2500 (64.3)	5200 (139)	9200 (247)	13000 (348)	18000 (482)	
	60	4.1	4450 (119)	9000 (241)	14550 (390)	15000 (402)		
	100	6.9	5500 (147)	9500 (255)	12900 (346) <sup>(1)</sup>			
125	8.6	7250 (194)	3900 (105) <sup>(1)</sup>					
7 inches w.c. (17 mbar) 655-697-004 1 inch w.c. (2 mbar) droop 2 inches w.c. (5 mbar) boost	0.4	0.028				950 (25.5)	1400 (37.5)	1600 (42.8)
	0.5	0.034				1500 (40.2)	1800 (48.2)	2000 (53.6)
	1	0.07	400 (10.7)	800 (21.4)	1200 (32.2)	2300 (61.6)	2800 (75.0)	3300 (88.4)
	1.5	0.10	500 (13.4)	1050 (28.1)	1600 (42.8)	3100 (83.1)	3600 (96.5)	4500 (121)
	2	0.14	600 (16.1)	1300 (34.8)	2000 (53.6)	4000 (107)	4500 (121)	6000 (161)
	5	0.34	1000 (26.8)	2100 (56.3)	3500 (93.8)	7700 (206)	9400 (252)	9400 (252)
	13	0.90	1650 (44.2)	3500 (93.8)	6400 (172)	10000 (268)	20200 (541)	21200 (568)
	25	1.7	2400 (64.3)	5200 (139)	10300 (276)	20000 (536)	11800 (316) <sup>(1)</sup>	
	60	4.1	4450 (119)	9000 (241)	12000 (322)	20700 (555)		
	100	6.9	7500 (201)	10000 (268)	13100 (351)			
125	8.6	9500 (255)	10300 (276)					
11 inches w.c. (17 mbar) 655-697-005 ± 2 inches w.c. (5 mbar)	0.5	0.03				800 (21.4)	1500 (40.2)	1600 (42.8)
	1	0.07	400 (10.7)	750 (20.1)	1100 (29.5)	1800 (48.2)	2500 (64.0)	2600 (69.7)
	1.5	0.10	500 (13.4)	1000 (26.8)	1450 (38.9)	2500 (67.0)	3400 (91.1)	3350 (89.8)
	2	0.14	600 (16.1)	1200 (32.2)	1700 (45.6)	3100 (83.1)	3600 (113)	3750 (101)
	5	0.34	1000 (26.8)	2000 (53.6)	3000 (80.4)	7300 (196)	7000 (188)	8500 (228)
	13	0.90	1600 (42.9)	3400 (91.1)	6200 (166)	10350 (277)	17650 (473)	18100 (485)
	25	1.7	2400 (64.3)	5650 (151)	10350 (277)	19300 (517)	23450 (628)	
	60	4.1	4450 (119)	11350 (304)	19300 (517)	20200 (541)		
	100	6.9	7450 (200)	16650 (446)	20200 (541)			
	125	8.6	9500 (255)	17500 (469)				
14 inches w.c. (35 mbar) 655-697-005 ± 2 inches w.c. (5 mbar)	1	0.07	450 (12.1)	700 (18.8)	1100 (29.5)	1500 (40.2)	1700 (45.6)	2700 (72.4)
	1.5	0.10	550 (14.7)	850 (22.8)	1200 (32.3)	1900 (50.9)	2700 (72.4)	3600 (96.5)
	2	0.14	600 (16.1)	1000 (26.8)	1900 (50.9)	2800 (75.0)	3800 (102)	3800 (102)
	5	0.34	1050 (28.1)	1750 (46.9)	2800 (75.0)	4000 (107)	5300 (142)	10600 (284)
	13	0.90	1750 (46.9)	3700 (99.2)	5700 (153)	14400 (386)	18000 (482)	18500 (496)
	25	1.7	2600 (69.7)	5700 (153)	10200 (273)	18000 (482)	25400 (681)	
	60	4.1	4800 (129)	10900 (292)	11000 (295)	19600 (525)		
	100	6.9	7400 (198)	16500 (442)	14100 (378)			
	125	8.6	9100 (244)	18000 (482)				
	20 inches w.c. (50 mbar) 655-697-006 ± 3 inches w.c. (7 mbar)	1	0.07	300 (8.04)	750 (20.1)	550 (14.7)	1250 (33.5)	1700 (45.6)
2		0.14	500 (13.4)	1150 (30.8)	1700 (45.6)	1900 (50.9)	2350 (62.9)	3250 (87.1)
5		0.34	900 (24.1)	1650 (44.2)	2150 (57.6)	3250 (87.1)	6400 (172)	6700 (180)
13		0.90	1500 (40.2)	2550 (68.3)	4350 (117)	5950 (159)	10150 (272)	10500 (281)
25		1.7	2450 (65.7)	4850 (130)	7200 (193)	18100 (485)	19200 (515)	
60		4.1	4900 (131)	9400 (252)	19600 (525)	22700 (608)		
100		6.9	7500 (201)	17400 (466)	13800 (370)			
125		8.6	9150 (245)	5500 (147) <sup>(1)</sup>				

**P212 Flow Capacities in SCFH** (Nm<sup>3</sup>/h) of 0.6 Specific Gravity Natural Gas

Outlet Pressure, Spring Part Number, and Accuracy	Inlet Pressure		NPT 1-1/2 Body Size					
			Orifice Size, Inches (mm)					
	PSIG	BAR	1/4 (6.4)	3/8 (9.5)	1/2 (13)	3/4 (19)	1 (25)	1-3/16 (30)
1 PSIG (0.07 BAR) 655-697-006  ±0.2 PSIG (0.014 BAR)	2	0.14	700 (18.8)	1250 (33.5)	1550 (41.5)	2900 (77.7)	3050 (81.7)	3250 (87.1)
	5	0.34	1050 (28.1)	2150 (57.6)	2800 (75.0)	4800 (129)	5600 (150)	6300 (169)
	10	0.69	1650 (44.2)	3200 (85.8)	4400 (118)	6550 (176)	7800 (209)	8150 (218)
	15	1.0	2000 (53.6)	4100 (110)	5750 (154)	8000 (214)	9400 (252)	10250 (275)
	20	1.4	2300 (61.6)	4750 (127)	6100 (163)	8700 (233)	10950 (293)	
	25	1.7	2600 (69.7)	5500 (147)	8200 (220)	9950 (267)	11550 (310)	
	30	2.1	2900 (77.7)	6250 (168)	8350 (224)	10800 (289)	12250 (328)	
	40	2.8	3600 (96.5)	7500 (201)	9350 (251)	10850 (291)		
	45	3.1	3900 (105)	8400 (225)	10350 (277)	11000 (295)		
	50	3.5	4250 (114)	8900 (239)	10950 (293)	11050 (296)		
	60	4.1	4950 (133)	10000 (268)	11000 (295)	11400 (306)		
	80	5.5	6150 (165)	11150 (299)	11350 (304)			
	100	6.9	7500 (201)	12000 (322)	12000 (322)			
	125	8.6	9150 (245)	12000 (322)				
1 PSIG (0.07 BAR) 655-697-006  ± 1% ABS ±0.16 psia (0.011 BAR)	2	0.14	650 (17.4)	1050 (28.1)	1350 (36.2)	2450 (65.7)	2700 (72.4)	3000 (80.4)
	5	0.34	1050 (28.1)	2100 (56.3)	2700 (72.4)	3800 (102)	4700 (126)	5200 (139)
	10	0.69	1500 (40.2)	2800 (75.0)	3700 (99.2)	5600 (150)	7000 (188)	7300 (196)
	15	1.0	1950 (52.3)	3750 (101)	4900 (131)	6900 (185)	8500 (228)	8750 (235)
	20	1.4	2200 (58.9)	4600 (123)	5800 (155)	8150 (218)	10350 (277)	
	25	1.7	2500 (67.0)	5000 (134)	7250 (194)	9050 (243)	10850 (291)	
	30	2.1	2800 (75.0)	6000 (161)	8200 (220)	9400 (252)	11000 (295)	
	40	2.8	3550 (95.1)	7350 (197)	9100 (244)	9500 (255)		
	45	3.1	3900 (105)	8250 (221)	9650 (259)	10100 (271)		
	50	3.5	4050 (109)	8450 (226)	10300 (276)	10300 (276)		
	60	4.1	4800 (129)	9050 (243)	10450 (280)	10550 (283)		
	80	5.5	5900 (158)	11000 (295)	11100 (297)			
	100	6.9	7400 (198)	11150 (299)	11500 (299)			
	125	8.6	9000 (241)	11750 (315)				
1 PSIG (0.07 BAR) 655-697-006  ± 2% ABS ±0.31 psia (0.021 BAR)	2	0.14	750 (20.1)	1450 (38.9)	2100 (56.3)	3700 (99.2)	4650 (125)	5350 (143)
	5	0.34	1250 (33.5)	2500 (67.0)	3550 (95.1)	6050 (162)	7900 (212)	7900 (212)
	10	0.69	1750 (46.9)	3450 (92.5)	5100 (137)	8550 (229)	9550 (256)	10100 (271)
	15	1.0	2050 (54.9)	4350 (117)	6700 (180)	9400 (252)	11250 (302)	11400 (306)
	20	1.4	2500 (67.0)	5150 (138)	8100 (217)	10500 (281)	12200 (327)	
	25	1.7	2700 (72.4)	5800 (155)	10100 (271)	11550 (310)	12600 (338)	
	30	2.1	3050 (81.7)	6650 (178)	10550 (283)	12350 (331)	13100 (351)	
	40	2.8	3700 (99.2)	7950 (212)	10550 (283)	12350 (331)		
	45	3.1	4100 (110)	8800 (236)	11800 (316)	12700 (340)		
	50	3.5	4550 (122)	9250 (248)	12000 (322)	13000 (348)		
	60	4.1	5000 (134)	10900 (292)	12600 (338)	13000 (348)		
	80	5.5	6450 (173)	12550 (336)	13000 (348)			
	100	6.9	7950 (213)	12900 (346)	13450 (360)			
	125	8.6	9450 (253)	13450 (360)				

**P212H Flow Capacities in SCFH** (Nm<sup>3</sup>/h) of 0.6 Specific Gravity Natural Gas NPT 1-1/2 Body Size

1 PSIG (0.07 BAR) 655-697-007  ±0.2 PSIG (0.014 BAR)	2	0.14	500 (13.4)	750 (20.1)	1750 (46.9)	2250 (60.3)	2400 (64.3)	2850 (76.4)
	5	0.34	1100 (29.5)	1800 (48.2)	2300 (61.6)	3400 (91.1)	4850 (130)	5350 (143)
	10	0.69	1600 (42.9)	3200 (85.8)	4600 (123)	7250 (194)	8800 (236)	8800 (236)
	30	2.1	2800 (75.0)	6300 (169)	7800 (209)	10400 (279)	11250 (302)	
	60	4.1	4900 (131)	9600 (257)	9650 (259)	11000 (295)		
	100	6.9	7300 (196)	11200 (300)	11950 (320)			
	125	8.6	9100 (244)	10550 (283) <sup>(1)</sup>				

1. Limited due to boost

- Shaded areas show where maximum operating inlet pressure for a given port diameter is exceeded.

**P212 Flow Capacities in SCFH** (Nm<sup>3</sup>/h) of 0.6 Specific Gravity Natural Gas



Outlet Pressure, Spring Part Number, and Accuracy	Inlet Pressure		NPT 2 (DN 50) Body Size					
			Orifice Size, Inches (mm)					
	PSIG	BAR	1/4 (6.4)	3/8 (9.5)	1/2 (13)	3/4 (19)	1 (25)	1-3/16 (30)
1 PSIG (0.07 BAR) 655-697-006 ±0.2 PSIG (0.014 BAR)	2	0.14	650 (17.4)	1200 (32.2)	2200 (58.9)	3200 (85.8)	3600 (96.5)	4500 (121)
	5	0.34	1100 (25.5)	2300 (61.6)	3200 (85.8)	4800 (129)	7700 (206)	10000 (268)
	10	0.69	1600 (42.9)	3000 (80.4)	4300 (115)	11400 (306)	15200 (407)	16300 (437)
	15	1.0	1900 (50.9)	4000 (107)	6900 (185)	15600 (418)	20800 (557)	22300 (598)
	20	1.4	2300 (61.6)	4900 (131)	9100 (244)	19000 (509)	24000 (643)	
	25	1.7	2600 (69.7)	5600 (150)	10500 (281)	21700 (582)	27400 (734)	
	30	2.1	2900 (77.7)	6500 (174)	11800 (316)	25300 (678)	32800 (879)	
	40	2.8	3700 (99.2)	8000 (214)	14500 (389)	27000 (724)		
	45	3.1	4000 (107)	8800 (236)	15800 (423)	27000 (724)		
	50	3.5	4300 (115)	9300 (249)	16600 (445)	28000 (750)		
	60	4.1	4900 (131)	11300 (303)	19500 (523)	31600 (847)		
	80	5.5	6300 (169)	14200 (381)	24000 (643)			
	100	6.9	7700 (206)	16700 (448)	29500 (791)			
125	8.6	9600 (257)	20200 (541)					
1 PSIG (0.07 BAR) 655-697-006 ± 1% ABS ±0.16 psia (0.011 BAR)	2	0.14	570 (15.3)	1100 (29.5)	2000 (53.6)	2750 (73.7)	3100 (83.1)	4000 (107)
	5	0.34	1050 (28.1)	2200 (58.9)	2750 (73.7)	4100 (110)	6250 (168)	9000 (241)
	10	0.69	1500 (40.2)	2500 (67.0)	4050 (109)	8500 (228)	13250 (355)	13700 (367)
	15	1.0	1900 (50.9)	3450 (92.5)	5800 (155)	15500 (415)	16000 (429)	16300 (437)
	20	1.4	2300 (61.6)	4800 (129)	7700 (206)	18300 (490)	20850 (559)	
	25	1.7	2500 (67.0)	5600 (150)	10400 (279)	21500 (576)	22800 (611)	
	30	2.1	2900 (77.7)	6350 (170)	11950 (320)	23800 (638)	24300 (651)	
	40	2.8	3650 (97.8)	7850 (210)	14550 (390)	24300 (651)		
	45	3.1	3850 (103)	8400 (225)	15600 (418)	25400 (681)		
	50	3.5	4250 (114)	9350 (251)	16700 (448)	26000 (697)		
	60	4.1	4900 (131)	11200 (300)	19400 (520)	32000 (858)		
	80	5.5	6200 (166)	14250 (382)	24600 (659)			
	100	6.9	7400 (198)	16750 (449)	29000 (777)			
125	8.6	9350 (251)	20200 (541)					
1 PSIG (0.07 BAR) 655-697-006 ± 2% ABS ±0.31 psia (0.021 BAR)	2	0.14	700 (18.8)	1450 (38.9)	2450 (65.7)	4100 (110)	5600 (150)	7900 (212)
	5	0.34	1150 (30.8)	2550 (68.3)	4000 (107)	8000 (214)	11700 (314)	14300 (383)
	10	0.69	1800 (48.2)	3550 (95.1)	6200 (166)	12300 (330)	18400 (493)	20000 (536)
	15	1.0	2050 (54.9)	4450 (119)	7850 (210)	15900 (426)	22000 (590)	24600 (659)
	20	1.4	2400 (64.3)	5250 (141)	9100 (244)	19200 (515)	25800 (691)	
	25	1.7	2750 (73.7)	5900 (158)	10300 (276)	21800 (584)	31200 (836)	
	30	2.1	3150 (84.4)	6550 (176)	11800 (316)	26200 (702)	35000 (938)	
	40	2.8	3750 (101)	8200 (220)	14300 (383)	30500 (817)		
	45	3.1	4050 (109)	8800 (236)	15600 (418)	28100 (753)		
	50	3.5	4400 (118)	9300 (249)	16700 (448)	33900 (909)		
	60	4.1	5050 (135)	10850 (291)	19500 (523)	34200 (917)		
	80	5.5	6350 (170)	13600 (364)	24600 (659)			
	100	6.9	7850 (210)	17000 (456)	30200 (809)			
125	8.6	9400 (252)	20500 (549)					

**P212H Flow Capacities in SCFH** (Nm<sup>3</sup>/h) of 0.6 Specific Gravity Natural Gas NPT 2 (DN 50) Body Size

1 PSIG (0.07 BAR) 655-697-007 ±0.2 PSIG (0.014 BAR)	2	0.14	500 (13.4)	1050 (28.1)	1400 (37.5)	2200 (58.9)	2900 (77.7)	3700 (99.2)
	5	0.34	1100 (29.5)	2000 (53.6)	2200 (58.9)	4500 (121)	6600 (177)	7000 (188)
	10	0.69	1600 (42.9)	3500 (93.8)	5700 (153)	9700 (260)	13000 (348)	13300 (356)
	30	2.1	2800 (75.0)	6200 (166)	11700 (314)	20000 (536)	23000 (616)	
	60	4.1	4900 (131)	10900 (292)	19300 (517)	20600 (552)		
	100	6.9	7500 (201)	17300 (464)	23900 (641)			
	125	8.6	9000 (241)	19900 (533)				

1. Limited due to boost

- Shaded areas show where maximum operating inlet pressure for a given port diameter is exceeded.

## P212H Flow Capacities in SCFH (Nm<sup>3</sup>/h) of 0.6 Specific Gravity Natural Gas

Outlet Pressure, Spring Part Number, and Accuracy	Inlet Pressure		NPT 1-1/2 Body Size					
			Orifice Size, Inches (mm)					
	PSIG	BAR	1/4 (6.4)	3/8 (9.5)	1/2 (13)	3/4 (19)	1 (25)	1-3/16 (30)
2 PSIG (0.14 BAR) 655-697-007  ±0.2 PSIG (0.014 BAR)	5	0.34	850 (22.8)	1600 (42.9)	1650 (44.2)	2400 (64.3)	2450 (65.7)	3900 (105)
	10	0.69	1450 (38.9)	2050 (54.9)	3250 (87.1)	5400 (145)	5750 (154)	6650 (178)
	15	1.0	1650 (44.2)	3000 (80.4)	4300 (115)	7000 (188)	8200 (220)	8200 (220)
	20	1.4	2050 (54.9)	3850 (103)	5650 (151)	7500 (201)	9050 (243)	
	25	1.7	2500 (67.0)	4600 (123)	6500 (174)	9600 (257)	9700 (260)	
	30	2.1	2750 (73.7)	5650 (151)	6500 (174)	9600 (257)	10850 (291)	
	40	2.8	3500 (93.8)	7000 (188)	8400 (225)	10150 (272)		
	45	3.1	3750 (101)	7800 (209)	9150 (245)	10500 (281)		
	50	3.5	4250 (114)	8500 (228)	9600 (257)	10500 (281)		
	60	4.1	4850 (130)	8800 (236)	9700 (260)	11400 (306)		
	80	5.5	6150 (165)	10000 (268)	11250 (302)			
	100	6.9	7600 (204)	10800 (289)	11250 (302)			
	125	8.6	9300 (249)	12200 (327)				
2 PSIG (0.14 BAR) 655-697-007  ±0.4 PSIG (0.028 BAR)	5	0.34	1100 (29.5)	2200 (58.9)	2800 (75.0)	4550 (122)	5600 (150)	6550 (176)
	10	0.69	1750 (46.9)	3150 (84.4)	4600 (123)	7550 (202)	9050 (243)	10150 (272)
	15	1.0	2000 (53.6)	4200 (113)	6400 (172)	10050 (269)	11000 (295)	11200 (300)
	20	1.4	2400 (64.3)	5000 (134)	7550 (202)	11700 (314)	12200 (327)	
	25	1.7	2700 (72.4)	5750 (154)	9600 (257)	11900 (319)	12950 (347)	
	30	2.1	3100 (83.1)	6700 (180)	9600 (257)	11900 (319)	13300 (356)	
	40	2.8	3750 (101)	7950 (213)	10750 (288)	13000 (348)		
	45	3.1	4100 (110)	8750 (235)	10750 (288)	13000 (348)		
	50	3.5	4550 (122)	9550 (256)	12700 (340)	13000 (348)		
	60	4.1	5150 (138)	11250 (302)	13300 (356)	14400 (386)		
	80	5.5	6450 (173)	12750 (342)	13300 (356)			
	100	6.9	7750 (208)	14450 (387)	13300 (356)			
	125	8.6	9400 (252)	14600 (391)				
2 PSIG (0.14 BAR) 655-697-007  ± 1% ABS ±0.17 psia (0.012 BAR)	5	0.34	850 (22.8)	1400 (37.5)	1450 (38.9)	2250 (60.3)	2450 (65.7)	3300 (88.4)
	10	0.69	1400 (37.5)	1650 (44.2)	2550 (68.3)	4350 (117)	5250 (141)	5600 (150)
	15	1.0	1500 (40.2)	2700 (72.4)	3800 (102)	6000 (161)	5400 (145)	8000 (214)
	20	1.4	2000 (53.6)	3600 (96.5)	5200 (139)	7200 (193)	8200 (220)	
	25	1.7	2400 (64.3)	4500 (121)	6400 (172)	9000 (241)	9550 (256)	
	30	2.1	2800 (75.0)	5600 (150)	7500 (201)	10000 (268)	10400 (279)	
	40	2.8	3600 (96.5)	7800 (209)	9200 (247)	10150 (272)		
	45	3.1	3900 (105)	8400 (225)	9800 (263)	10900 (292)		
	50	3.5	4300 (115)	9100 (244)	10300 (276)	10600 (284)		
	60	4.1	5000 (134)	10200 (273)	11400 (306)	11300 (303)		
	80	5.5	6400 (172)	12000 (322)	10300 (276)(1)			
	100	6.9	7900 (212)	13000 (348)	11150 (299)(1)			
	125	8.6	9600 (257)	11950 (320)(1)				
2 PSIG (0.14 BAR) 655-697-007  ± 2% ABS ±0.33 psia (0.023 BAR)	5	0.34	1050 (28.1)	2100 (56.3)	2500 (67.0)	4100 (110)	5200 (139)	6250 (168)
	10	0.69	1650 (44.2)	3050 (81.7)	4200 (113)	6400 (172)	8350 (224)	8850 (237)
	15	1.0	1900 (50.9)	4200 (113)	6200 (166)	8800 (236)	10500 (281)	10750 (288)
	20	1.4	2200 (58.9)	5100 (137)	7600 (204)	10300 (276)	12000 (322)	
	25	1.7	2500 (67.0)	5800 (155)	8700 (233)	11800 (316)	12050 (323)	
	30	2.1	3000 (80.4)	6500 (174)	9600 (257)	12600 (338)	12700 (340)	
	40	2.8	3600 (96.5)	8100 (217)	11500 (308)	12700 (340)		
	45	3.1	3900 (105)	8800 (236)	12000 (322)	12800 (343)		
	50	3.5	4300 (115)	9700 (260)	12600 (338)	12900 (346)		
	60	4.1	5000 (134)	11300 (303)	13600 (364)	13700 (367)		
	80	5.5	6400 (172)	14200 (381)	12650 (339)			
	100	6.9	7900 (212)	15500 (415)	12950 (347)			
	125	8.6	9600 (257)	14200 (381)(1)				

1. Limited due to boost

 - Shaded areas show where maximum operating inlet pressure for a given port diameter is exceeded.

**P212H Flow Capacities in SCFH** (Nm<sup>3</sup>/h) of 0.6 Specific Gravity Natural Gas



Outlet Pressure, Spring Part Number, and Accuracy	Inlet Pressure		NPT 2 (DN 50) Body Size					
			Orifice Size, Inches (mm)					
	PSIG	BAR	1/4 (6.4)	3/8 (9.5)	1/2 (13)	3/4 (19)	1 (25)	1-3/16 (30)
2 PSIG (0.14 BAR)  655-697-007  ±0.2 PSIG (0.014 BAR)	5	0.34	850 (22.8)	1800 (48.2)	1800 (48.2)	2950 (79.1)	4250 (114)	5200 (139)
	10	0.69	1350 (36.2)	1900 (50.9)	3000 (80.4)	5200 (139)	6600 (177)	7800 (209)
	15	1.0	1700 (45.6)	2800 (75.0)	3700 (99.2)	6900 (185)	7200 (193)	9500 (255)
	20	1.4	2000 (53.6)	3800 (102)	5300 (142)	9000 (241)	9800 (263)	
	25	1.7	2450 (65.7)	4500 (121)	6800 (182)	12500 (335)	14200 (381)	
	30	2.1	2650 (71.0)	5200 (139)	7500 (201)	16000 (429)	16100 (431)	
	40	2.8	3400 (91.1)	7400 (198)	13200 (354)	21600 (579)		
	45	3.1	3600 (96.1)	8000 (214)	15500 (415)	21600 (579)		
	50	3.5	4000 (107)	8500 (228)	16700 (448)	21900 (587)		
	60	4.1	4600 (123)	10700 (287)	19200 (515)	18800 (504) <sup>(1)</sup>		
	80	5.5	5800 (155)	13100 (351)	24800 (665)			
	100	6.9	7100 (190)	16200 (434)	25600 (686)			
	125	8.6	9000 (241)	19900 (533)				
2 PSIG (0.14 BAR)  655-697-007  ±0.4 PSIG (0.028 BAR)	5	0.34	1100 (29.5)	2250 (60.3)	3200 (85.8)	5500 (147)	7800 (209)	10100 (271)
	10	0.69	1600 (42.9)	3250 (87.1)	5400 (145)	10000 (268)	14100 (378)	15100 (405)
	15	1.0	2000 (53.6)	4150 (111)	7200 (193)	14400 (386)	18600 (498)	22100 (592)
	20	1.4	2300 (61.6)	4950 (133)	9000 (241)	17500 (469)	24000 (643)	
	25	1.7	2650 (71.0)	5800 (155)	10200 (273)	20700 (555)	28000 (750)	
	30	2.1	3100 (83.1)	6600 (177)	11800 (316)	24900 (667)	28500 (764)	
	40	2.8	3600 (96.5)	8100 (217)	14600 (391)	28000 (750)		
	45	3.1	4100 (110)	8850 (237)	15800 (423)	29000 (777)		
	50	3.5	4400 (118)	9850 (264)	17200 (461)	29200 (783)		
	60	4.1	4900 (131)	11300 (303)	19500 (523)	29300 (785)		
	80	5.5	6400 (172)	14300 (383)	24500 (657)			
	100	6.9	7600 (204)	17200 (461)	29700 (796)			
	125	8.6	9400 (252)	20500 (549)				
2 PSIG (0.14 BAR)  655-697-007  ± 1% ABS ±0.17 psia (0.012 BAR)	5	0.34	750 (20.1)	1600 (42.9)	1600 (42.9)	2400 (64.3)	3000 (80.4)	4100 (110)
	10	0.69	1250 (33.5)	1600 (42.9)	2550 (68.3)	4250 (114)	5000 (134)	6100 (163)
	15	1.0	1600 (42.9)	2700 (72.4)	3800 (102)	5200 (139)	6900 (185)	7600 (204)
	20	1.4	2000 (53.6)	3600 (96.5)	5200 (139)	6900 (185)	9400 (252)	
	25	1.7	2450 (65.7)	4400 (118)	7500 (201)	9600 (257)	10650 (285)	
	30	2.1	2800 (75.0)	5200 (139)	8600 (230)	11800 (316)	16100 (431)	
	40	2.8	3700 (99.2)	7500 (201)	12200 (327)	16200 (434)		
	45	3.1	4100 (110)	8400 (225)	15200 (407)	18350 (492)		
	50	3.5	4400 (118)	9000 (241)	16900 (453)	21000 (563)		
	60	4.1	5100 (137)	11000 (295)	20800 (557)	21000 (563)		
	80	5.5	6500 (174)	14600 (391)	24800 (665)			
	100	6.9	8000 (214)	18000 (482)	29300 (785)			
	125	8.6	9800 (263)	20500 (549)				
2 PSIG (0.14 BAR)  655-697-007  ± 2% ABS ±0.33 psia (0.023 BAR)	5	0.34	1000 (26.8)	2150 (57.6)	2750 (73.7)	5000 (134)	6200 (166)	7900 (212)
	10	0.69	1550 (41.5)	3050 (81.7)	5000 (134)	8600 (230)	12750 (342)	13800 (370)
	15	1.0	1900 (50.9)	4200 (113)	7200 (193)	11000 (295)	11750 (315)	21700 (582)
	20	1.4	2300 (61.6)	5100 (137)	9200 (247)	14200 (381)	16000 (429)	
	25	1.7	2600 (69.7)	5900 (158)	10700 (287)	16400 (440)	25400 (681)	
	30	2.1	3000 (80.4)	6600 (177)	12100 (324)	19700 (528)	27900 (748)	
	40	2.8	3700 (99.2)	8200 (220)	12200 (327)	27200 (729)		
	45	3.1	4100 (110)	9000 (241)	15200 (407)	27200 (729)		
	50	3.5	4400 (118)	9700 (260)	16900 (453)	27400 (734)		
	60	4.1	5100 (137)	11300 (303)	20800 (557)	27400 (734)		
	80	5.5	6500 (174)	14600 (391)	24500 (657)			
	100	6.9	8000 (214)	18000 (482)	29600 (793)			
	125	8.6	9800 (263)	20500 (549)				

1. Limited due to boost

- Shaded areas show where maximum operating inlet pressure for a given port diameter is exceeded.

**P212H Flow Capacities in SCFH** (Nm<sup>3</sup>/h) of 0.6 Specific Gravity Natural Gas

Outlet Pressure, Spring Part Number, and Accuracy	Inlet Pressure		NPT 1-1/2 Body Size					
			Orifice Size, Inches (mm)					
	PSIG	BAR	1/4 (6.4)	3/8 (9.5)	1/2 (13)	3/4 (19)	1 (25)	1-3/16 (30)
3 PSIG (0.21 BAR) 655-697-008  ±0.3 PSIG (0.021 BAR)	5	0.34	800 (21.4)	1350 (36.2)	1650 (44.2)	2500 (67.0)	2500 (67.0)	3850 (103)
	10	0.69	1200 (32.2)	1800 (48.2)	2650 (71.0)	4600 (123)	6050 (162)	6600 (177)
	15	1.0	1650 (44.2)	2300 (61.6)	3750 (101)	5600 (174)	9200 (247)	8200 (220)
	20	1.4	1950 (52.3)	3500 (93.8)	5000 (134)	8350 (224)	9200 (247)	
	25	1.7	2150 (57.6)	4400 (118)	6500 (174)	8150 (218)	10050 (269)	
	30	2.1	2700 (72.4)	5600 (150)	6700 (180)	10050 (269)	11250 (302)	
	40	2.8	3300 (88.4)	6900 (185)	7900 (212)	10300 (275)		
	45	3.1	3550 (95.1)	7000 (188)	8650 (232)	11000 (295)		
	50	3.5	4050 (109)	7800 (209)	9700 (260)	11000 (295)		
	60	4.1	4250 (114)	8200 (220)	9900 (265)	11450 (307)		
	80	5.5	5950 (159)	10000 (268)	11600 (311)			
	100	6.9	7450 (200)	11750 (315)	11900 (319)			
	125	8.6	8800 (236)	12200 (327)				
3 PSIG (0.21 BAR) 655-697-008  ±0.6 PSIG (0.041 BAR)	5	0.34	1100 (29.5)	1950 (52.3)	2800 (75.0)	4250 (114)	5400 (145)	7200 (193)
	10	0.69	1650 (44.2)	3100 (83.1)	4650 (125)	7750 (208)	8700 (233)	9100 (244)
	15	1.0	2050 (54.9)	4100 (110)	5950 (159)	9550 (256)	11150 (299)	11800 (316)
	20	1.4	2400 (64.3)	4900 (131)	7800 (209)	10650 (285)	12350 (331)	
	25	1.7	2600 (69.7)	5750 (154)	8700 (233)	11950 (320)	14050 (377)	
	30	2.1	3100 (83.1)	6550 (176)	10250 (275)	12050 (323)	14400 (386)	
	40	2.8	3150 (84.4)	7850 (210)	11300 (303)	13800 (370)		
	45	3.1	4150 (111)	8400 (225)	12450 (334)	14150 (379)		
	50	3.5	4400 (118)	9300 (249)	12450 (334)	14150 (379)		
	60	4.1	5000 (134)	10700 (287)	13000 (348)	15350 (411)		
	80	5.5	6400 (172)	13050 (350)	16000 (429)			
	100	6.9	7650 (205)	15400 (413)	16050 (430)			
	125	8.6	9200 (247)	16050 (430)				
3 PSIG (0.21 BAR) 655-697-008  ± 1% ABS ±0.18 psia (0.012 BAR)	5	0.34	500 (13.4)	1150 (30.8)	1200 (32.2)	1450 (38.9)	1550 (41.5)	2100 (56.3)
	10	0.69	900 (24.1)	1350 (36.2)	1500 (40.2)	2750 (73.7)	3200 (85.8)	3400 (91.1)
	15	1.0	1200 (32.2)	1700 (45.6)	2200 (58.9)	3900 (105)	4900 (131)	4950 (133)
	20	1.4	1500 (40.2)	2100 (56.3)	2900 (77.7)	5300 (142)	8000 (214)	
	25	1.7	1900 (50.9)	2600 (69.7)	4300 (115)	7400 (198)	9350 (251)	
	30	2.1	2200 (58.9)	3100 (83.1)	5100 (137)	8400 (225)	8650 (232) <sup>(1)</sup>	
	40	2.8	2900 (77.7)	4800 (129)	8000 (214)	8750 (235)		
	45	3.1	3300 (88.4)	5800 (155)	9300 (249)	9900 (265)		
	50	3.5	3700 (99.2)	6800 (182)	10200 (273)	10600 (284)		
	60	4.1	4400 (118)	8400 (225)	11600 (311)	10700 (287)		
	80	5.5	6300 (169)	10800 (289)	9400 (252) <sup>(1)</sup>			
	100	6.9	8100 (217)	12100 (324)	11750 (315)			
	125	8.6	10000 (268)	10750 (288) <sup>(1)</sup>				
3 PSIG (0.21 BAR) 655-697-008  ± 2% ABS ±0.35 psia (0.024 BAR)	5	0.34	900 (24.1)	1450 (38.9)	1800 (48.2)	3000 (80.4)	3000 (80.4)	4650 (125)
	10	0.69	1250 (33.5)	2050 (54.9)	3150 (84.4)	5150 (138)	6450 (173)	6650 (178)
	15	1.0	1800 (48.2)	3100 (83.1)	4400 (118)	7200 (193)	8700 (233)	8700 (233)
	20	1.4	2200 (58.9)	3800 (102)	6100 (163)	8600 (230)	11000 (295)	
	25	1.7	2600 (69.7)	5000 (134)	7600 (204)	9700 (260)	11050 (296)	
	30	2.1	2900 (77.7)	5800 (155)	8700 (233)	11200 (300)	11450 (3070)	
	40	2.8	3600 (96.5)	7800 (209)	10800 (289)	11600 (311)		
	45	3.1	4000 (107)	8400 (225)	11600 (311)	11600 (311)		
	50	3.5	4600 (123)	9400 (252)	12400 (332)	11750 (315)		
	60	4.1	5100 (137)	10600 (284)	13800 (370)	13250 (355)		
	80	5.5	6500 (174)	12700 (340)	12600 (338) <sup>(1)</sup>			
	100	6.9	8100 (217)	14400 (386)	12550 (336) <sup>(1)</sup>			
	125	8.6	10000 (268)	12500 (335) <sup>(1)</sup>				

1. Limited due to boost

 - Shaded areas show where maximum operating inlet pressure for a given port diameter is exceeded.

**P212H Flow Capacities in SCFH** (Nm<sup>3</sup>/h) of 0.6 Specific Gravity Natural Gas



Outlet Pressure, Spring Part Number, and Accuracy	Inlet Pressure		NPT 2 (DN 50) Body Size					
			Orifice Size, Inches (mm)					
	PSIG	BAR	1/4 (6.4)	3/8 (9.5)	1/2 (13)	3/4 (19)	1 (25)	1-3/16 (30)
3 PSIG (0.21 BAR)  655-697-008  ±0.3 PSIG (0.021 BAR)	5	0.34	750 (20.1)	1400 (37.5)	1600 (42.9)	2400 (64.3)	2900 (77.7)	3500 (93.8)
	10	0.69	1200 (32.2)	1900 (50.9)	2750 (73.7)	5000 (134)	6400 (171)	6900 (185)
	15	1.0	1400 (37.5)	2000 (53.6)	3100 (83.1)	5900 (158)	7700 (206)	9800 (263)
	20	1.4	1850 (49.6)	3000 (80.4)	4150 (111)	7700 (206)	7900 (212)	
	25	1.7	2050 (54.9)	3900 (105)	5000 (134)	9100 (244)	9750 (261)	
	30	2.1	2550 (68.3)	4800 (129)	6700 (180)	10100 (271)	17200 (461)	
	40	2.8	3150 (84.4)	6250 (168)	8700 (233)	11600 (311)		
	45	3.1	3400 (91.1)	6750 (181)	9900 (265)	14500 (389)		
	50	3.5	3900 (105)	6750 (181)	12300 (330)	13900 (373)		
	60	4.1	4350 (117)	9400 (252)	12700 (340)	18300 (490)		
	80	5.5	5600 (150)	12700 (340)	18800 (504)			
	100	6.9	7000 (188)	14800 (397)	18800 (504)			
	125	8.6	8650 (232)	18800 (504)				
3 PSIG (0.21 BAR)  655-697-008  ±0.6 PSIG (0.041 BAR)	5	0.34	1100 (29.5)	1950 (52.3)	2550 (68.3)	4700 (126)	6000 (161)	7450 (200)
	10	0.69	1550 (41.5)	3000 (80.4)	4750 (127)	8600 (230)	12200 (327)	15400 (413)
	15	1.0	2050 (54.9)	3850 (103)	5950 (159)	12500 (338)	16200 (434)	20300 (544)
	20	1.4	2400 (64.3)	4850 (130)	8200 (220)	17000 (456)	21800 (584)	
	25	1.7	2800 (75.0)	5750 (154)	9800 (263)	19700 (528)	23000 (616)	
	30	2.1	3150 (84.4)	6450 (173)	11600 (311)	22500 (603)	26500 (710)	
	40	2.8	3650 (97.8)	7850 (210)	14300 (383)	26400 (708)		
	45	3.1	4100 (110)	8900 (239)	15500 (415)	28500 (764)		
	50	3.5	4350 (117)	9450 (253)	17000 (456)	29600 (793)		
	60	4.1	5100 (137)	11100 (297)	19850 (532)	29900 (801)		
	80	5.5	6350 (170)	14350 (385)	25200 (675)			
	100	6.9	7250 (194)	17250 (462)	29400 (788)			
	125	8.6	9400 (252)	21000 (563)				
3 PSIG (0.21 BAR)  655-697-008  ± 1% ABS ±0.18 psia (0.012 BAR)	5	0.34	650 (17.4)	1100 (29.3)	790 (21.2)	1500 (40.2)	1700 (45.6)	1750 (46.9)
	10	0.69	1000 (26.8)	1250 (33.5)	1500 (40.2)	2500 (67.0)	3700 (99.2)	4300 (115)
	15	1.0	1250 (33.5)	1750 (46.9)	2000 (53.6)	2900 (77.7)	3750 (101)	6000 (161)
	20	1.4	1450 (38.9)	2400 (64.3)	2200 (58.9)	4100 (110)	5750 (154)	
	25	1.7	1600 (42.8)	2900 (77.7)	4000 (107)	6900 (185)	6400 (172)	
	30	2.1	1950 (52.3)	3550 (95.1)	4400 (118)	8700 (233)	6700 (180)	
	40	2.8	2700 (72.4)	3850 (103)	5500 (147)	6450 (173)		
	45	3.1	2900 (77.7)	5400 (145)	9000 (241)	8000 (214)		
	50	3.5	3300 (88.4)	5700 (153)	9100 (244)	7900 (212)		
	60	4.1	3900 (105)	7200 (193)	11500 (308)	10300 (276)		
	80	5.5	5250 (141)	9200 (247)	9800 (263) <sup>(1)</sup>			
	100	6.9	6250 (168)	11300 (303)	10900 (292) <sup>(1)</sup>			
	125	8.6	7750 (208)	12650 (339)				
3 PSIG (0.21 BAR)  655-697-008  ± 2% ABS ±0.35 psia (0.024 BAR)	5	0.34	800 (21.4)	1450 (38.9)	1700 (45.6)	3150 (84.4)	3250 (87.1)	4000 (107)
	10	0.69	1300 (34.8)	2150 (57.6)	3200 (85.8)	5550 (149)	7200 (193)	9000 (241)
	15	1.0	1550 (41.5)	2850 (76.4)	4050 (109)	6800 (182)	8250 (221)	10800 (289)
	20	1.4	1850 (49.6)	3300 (88.4)	5400 (145)	9300 (249)	10900 (292)	
	25	1.7	2350 (62.9)	4650 (125)	6700 (180)	11250 (302)	15600 (418)	
	30	2.1	2450 (65.7)	5100 (137)	8600 (230)	12250 (328)	17350 (465)	
	40	2.8	3150 (84.4)	6950 (186)	11400 (306)	15150 (406)		
	45	3.1	3400 (91.1)	7650 (205)	11900 (319)	18150 (486)		
	50	3.5	3800 (102)	8500 (228)	14000 (375)	20200 (541)		
	60	4.1	4300 (115)	9850 (264)	19000 (509)	21150 (567)		
	80	5.5	5500 (147)	12600 (338)	23100 (619)			
	100	6.9	6500 (174)	15500 (415)	23650 (634)			
	125	8.6	8100 (217)	20650 (553)				

1. Limited due to boost

- Shaded areas show where maximum operating inlet pressure for a given port diameter is exceeded.

## P212H Flow Capacities in SCFH (Nm<sup>3</sup>/h) of 0.6 Specific Gravity Natural Gas

Outlet Pressure, Spring Part Number, and Accuracy	Inlet Pressure		NPT 1-1/2 Body Size					
			Orifice Size, Inches (mm)					
	PSIG	BAR	1/4 (6.4)	3/8 (9.5)	1/2 (13)	3/4 (19)	1 (25)	1-3/16 (30)
5 PSIG (0.34 BAR) 655-697-009  ±0.5 PSIG (0.034 BAR)	10	0.69	1200 (32.2)	1850 (49.6)	2300 (61.6)	3350 (89.8)	4750 (127)	5500 (147)
	15	1.0	1350 (36.2)	2450 (65.7)	3200 (85.8)	5350 (141)	6650 (178)	7550 (202)
	20	1.4	1850 (49.6)	3200 (85.8)	3900 (105)	6700 (180)	8600 (230)	
	25	1.7	2200 (58.9)	3600 (96.5)	4900 (131)	8250 (221)	10000 (268)	
	30	2.1	2500 (67.0)	5100 (137)	6500 (174)	8800 (236)	11450 (307)	
	40	2.8	3250 (87.1)	6100 (163)	7650 (205)	10650 (285)		
	45	3.1	3650 (97.8)	6950 (186)	8500 (228)	11200 (300)		
	50	3.5	3850 (103)	7550 (202)	9250 (248)	12250 (328)		
	60	4.1	4600 (123)	8550 (229)	10300 (276)	12950 (347)		
	80	5.5	5900 (158)	10550 (283)	12500 (335)			
	100	6.9	7250 (194)	12000 (322)	12550 (336)			
	125	8.6	9000 (241)	13300 (356)				
5 PSIG (0.34 BAR) 655-697-009  ±1 PSIG (0.69 BAR)	10	0.69	1550 (41.5)	2850 (76.4)	4050 (109)	6450 (173)	8450 (226)	9800 (263)
	15	1.0	2000 (53.6)	3850 (103)	5800 (155)	9250 (248)	11150 (299)	12400 (332)
	20	1.4	2450 (65.7)	4750 (127)	7150 (192)	11400 (306)	13250 (355)	
	25	1.7	2800 (75.0)	5700 (153)	8600 (230)	12800 (343)	15250 (409)	
	30	2.1	3100 (83.1)	6400 (172)	10050 (269)	13550 (363)	16800 (450)	
	40	2.8	3700 (99.2)	7850 (210)	12350 (331)	15650 (419)		
	45	3.1	4050 (109)	8600 (230)	13000 (348)	15950 (427)		
	50	3.5	4450 (119)	9400 (252)	13650 (366)	16300 (437)		
	60	4.1	5050 (135)	10700 (287)	15100 (405)	18200 (488)		
	80	5.5	6300 (169)	13400 (359)	17650 (473)			
	100	6.9	7600 (204)	15950 (427)	17650 (473)			
	125	8.6	9200 (247)	17800 (477)				
5 PSIG (0.34 BAR) 655-697-009  ± 1% ABS ±0.20 psia (0.014 BAR)	10	0.69	650 (17.4)	900 (24.1)	1050 (28.1)	1200 (32.2)	1950 (52.3)	2200 (58.9)
	15	1.0	800 (21.4)	1100 (29.5)	1500 (40.2)	2000 (53.6)	2600 (69.7)	3400 (91.1)
	20	1.4	1050 (28.1)	1400 (37.5)	2050 (54.9)	2800 (75.0)	3800 (102)	
	25	1.7	1200 (32.2)	1800 (48.2)	2350 (62.9)	3800 (102)	4400 (118)	
	30	2.1	1450 (38.9)	2200 (58.9)	3000 (80.4)	4900 (131)	5250 (141)	
	40	2.8	1950 (52.3)	2950 (79.1)	4400 (118)	5750 (154)		
	45	3.1	2200 (58.9)	3300 (88.4)	5000 (134)	6550 (176)		
	50	3.5	2400 (64.3)	3850 (103)	6200 (166)	8200 (220)		
	60	4.1	2950 (79.1)	4800 (129)	8400 (225)	9250 (248)		
	80	5.5	4000 (107)	7400 (198)	7800 (209)			
	100	6.9	5300 (142)	10700 (287)	9200 (247)			
	125	8.6	7200 (193)	6150 (165) <sup>(1)</sup>				
5 PSIG (0.34 BAR) 655-697-009  ± 2% ABS ±0.39 psia (0.028 BAR)	10	0.69	1050 (28.1)	1650 (44.2)	1950 (52.3)	2600 (69.7)	3700 (99.2)	4900 (131)
	15	1.0	1350 (36.2)	2050 (54.9)	2900 (77.7)	4300 (115)	5600 (150)	6350 (170)
	20	1.4	1750 (46.9)	2700 (72.4)	3900 (105)	5800 (155)	7400 (198)	
	25	1.7	2100 (56.3)	3350 (89.8)	4850 (130)	7300 (196)	8750 (235)	
	30	2.1	2400 (64.3)	4050 (109)	5750 (154)	8700 (233)	10150 (272)	
	40	2.8	3200 (85.8)	5300 (142)	8000 (214)	9800 (263)		
	45	3.1	3500 (93.8)	6050 (162)	8950 (240)	10750 (288)		
	50	3.5	3900 (105)	6800 (182)	9800 (263)	11000 (295)		
	60	4.1	4700 (126)	8400 (225)	11500 (308)	12100 (324)		
	80	5.5	6150 (165)	11100 (297)	10300 (276) <sup>(1)</sup>			
	100	6.9	7900 (212)	13100 (351)	11200 (300) <sup>(1)</sup>			
	125	8.6	9700 (260)	11950 (320) <sup>(1)</sup>				

1. Limited due to boost

 - Shaded areas show where maximum operating inlet pressure for a given port diameter is exceeded.

**P212H Flow Capacities in SCFH** (Nm<sup>3</sup>/h) of 0.6 Specific Gravity Natural Gas



Outlet Pressure, Spring Part Number, and Accuracy	Inlet Pressure		NPT 2 (DN 50) Body Size					
			Orifice Size, Inches (mm)					
	PSIG	BAR	1/4 (6.4)	3/8 (9.5)	1/2 (13)	3/4 (19)	1 (25)	1-3/16 (30)
5 PSIG (0.34 BAR) 655-697-009 ±0.5 PSIG (0.034 BAR)	10	0.69	1200 (32.2)	1700 (45.6)	2200 (58.9)	3750 (101)	5300 (142)	5800 (155)
	15	1.0	1400 (37.5)	2100 (56.3)	2850 (76.4)	5500 (147)	6850 (184)	8150 (218)
	20	1.4	1800 (48.2)	2850 (76.4)	3750 (101)	7000 (188)	7700 (206)	
	25	1.7	2050 (54.9)	3750 (101)	4550 (122)	7900 (212)	9750 (261)	
	30	2.1	2500 (67.0)	4550 (122)	5800 (155)	8500 (228)	10750 (288)	
	40	2.8	3150 (84.4)	5800 (155)	6200 (166)	12000 (322)		
	45	3.1	3500 (93.8)	6200 (166)	7000 (188)	12850 (344)		
	50	3.5	3900 (105)	7000 (188)	7700 (206)	14200 (381)		
	60	4.1	4350 (117)	7700 (206)	10950 (293)	16650 (446)		
	80	5.5	5850 (157)	10950 (293)	13500 (362)			
	100	6.9	7150 (192)	13500 (362)	16400 (440)			
	125	8.6	8900 (239)	16400 (440)				
5 PSIG (0.34 BAR) 655-697-009 ±1 PSIG (0.69 BAR)	10	0.69	1500 (40.2)	2800 (75.0)	4050 (109)	7350 (197)	9400 (252)	12400 (332)
	15	1.0	2050 (54.9)	3950 (106)	5700 (153)	10750 (288)	12950 (347)	17100 (458)
	20	1.4	2400 (64.3)	4750 (127)	7300 (196)	13550 (363)	18450 (494)	
	25	1.7	2750 (73.7)	5450 (146)	9100 (244)	16200 (434)	20400 (547)	
	30	2.1	3100 (83.1)	6500 (174)	10500 (281)	19200 (515)	24700 (662)	
	40	2.8	3750 (101)	7850 (210)	13700 (367)	25250 (677)		
	45	3.1	4050 (109)	8550 (229)	15150 (406)	25700 (689)		
	50	3.5	4400 (118)	9600 (257)	16650 (446)	27950 (749)		
	60	4.1	4950 (133)	10850 (291)	19150 (513)	30550 (819)		
	80	5.5	6450 (173)	14000 (375)	24150 (647)			
	100	6.9	7700 (206)	17000 (456)	29400 (788)			
	125	8.6	9250 (248)	20700 (555)				
5 PSIG (0.34 BAR) 655-697-009 ± 1% ABS ±0.20 psia (0.014 BAR)	10	0.69	500 (13.4)	850 (22.8)	1000 (26.8)	1500 (40.2)	2000 (53.6)	2200 (58.9)
	15	1.0	750 (20.1)	1200 (32.2)	1400 (37.5)	1900 (50.9)	2300 (61.6)	2900 (77.7)
	20	1.4	1000 (26.8)	1550 (41.5)	1900 (50.9)	2700 (72.4)	3000 (80.4)	
	25	1.7	1250 (33.5)	1950 (52.3)	2300 (61.6)	3400 (91.1)	3700 (99.2)	
	30	2.1	1450 (38.9)	2200 (58.9)	2800 (75.0)	4100 (110)	4000 (107)	
	40	2.8	1900 (50.9)	3100 (83.1)	4000 (107)	3300 (88.4)		
	45	3.1	2100 (56.3)	3400 (91.1)	4400 (118)	4600 (123)		
	50	3.5	2400 (64.3)	3800 (102)	5000 (134)	5300 (142)		
	60	4.1	2800 (75.0)	4700 (126)	6600 (177)	7250 (194)		
	80	5.5	3900 (105)	7300 (196)	5050 (135) <sup>(1)</sup>			
	100	6.9	5000 (134)	9300 (249)	6400 (172) <sup>(1)</sup>			
	125	8.6	7000 (188)	6000 (161) <sup>(1)</sup>				
5 PSIG (0.34 BAR) 655-697-009 ± 2% ABS ±0.39 psia (0.028 BAR)	10	0.69	1000 (26.8)	1400 (37.5)	1650 (44.2)	2900 (77.7)	3500 (93.8)	4500 (121)
	15	1.0	1300 (34.8)	2100 (56.3)	2800 (75.0)	3900 (105)	5500 (147)	5850 (157)
	20	1.4	1650 (44.2)	2750 (73.7)	3600 (96.5)	5300 (142)	7400 (198)	
	25	1.7	2050 (54.9)	3400 (91.1)	4400 (118)	6800 (182)	7400 (196)	
	30	2.1	2400 (64.3)	4000 (107)	5500 (147)	7900 (212)	8350 (224)	
	40	2.8	3100 (83.1)	5400 (145)	7200 (193)	9300 (249)		
	45	3.1	3250 (87.1)	6100 (163)	8300 (222)	9850 (264)		
	50	3.5	3850 (103)	6700 (180)	9400 (252)	10650 (285)		
	60	4.1	4450 (119)	8200 (220)	11500 (308)	14550 (390)		
	80	5.5	6100 (163)	11000 (295)	10850 (291) <sup>(1)</sup>			
	100	6.9	7600 (204)	14000 (375)	11800 (316)			
	125	8.6	9600 (257)	11650 (312) <sup>(1)</sup>				

1. Limited due to boost

- Shaded areas show where maximum operating inlet pressure for a given port diameter is exceeded.

# P212 Parts Drawing

## P212

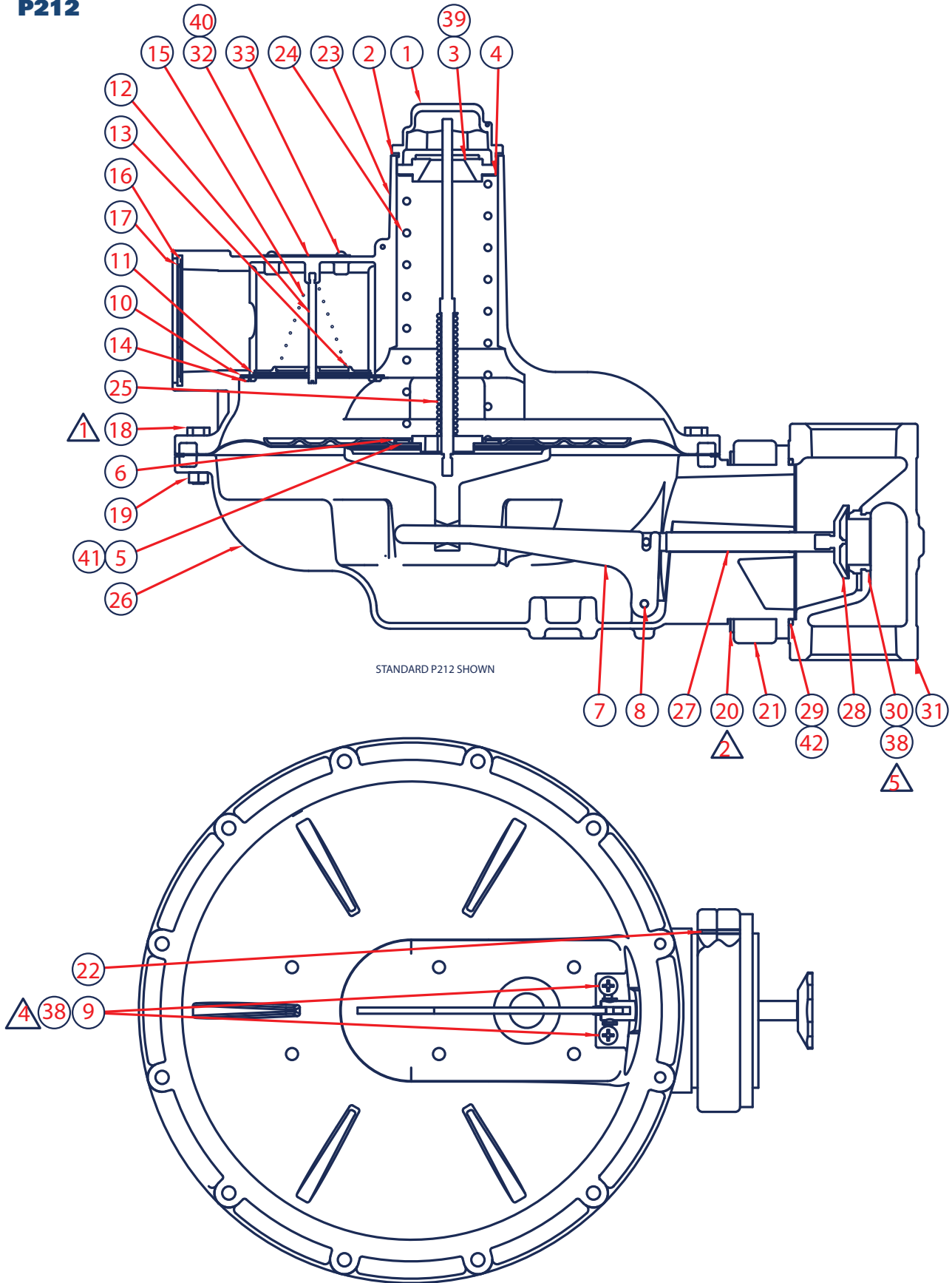

Item	Description	Part Number
1	Bonnet Cap - Aluminum	1 610-058-000
2	Cap Gasket - Neoprene	1 624-068-000
3	Adjusting Screw	1 648-504-000
4	Thrust Washer	1 662-234-001
5	Roller Bearing	1 602-135-000
6	Bearing Washer	1 662-243-000
7	Lever - Plated Steel	1 730-000-000
8	Lever Pin - Stainless	1 635-064-000
9	Lever Screws - Plated Steel	2 648-503-000
<b>Vent Assembly Parts</b>		
10	Seat Plate	1 650-203-000
11	Seat Plate Gasket	1 624-109-000
12	Flapper Stem	1 638-092-000
13	Flapper Plate	1 661-009-000
14	Self-tapping Screw	4 648-502-000
15	Port Spring	1 655-789-001
16	Port Screen	1 647-028-000
17	Snap Ring	1 693-035-000
18	Build Screws - Plated Steel	12 648-506-000
19	Build Screw Nuts - Plated Steel	10 634-174-000
20	Union Ring Bolt - Plated Steel	4 648-467-010
21	Union Ring - Aluminum	2 644-067-000
22	Union Ring Spring Pin - Stainless	1 635-086-000
23	Bonnet - Aluminum - <b>L Only</b>	1 604-276-000
	Bonnet - Aluminum - <b>H Only</b>	1 800-134-000
<b>Range Springs - Normal (L)</b>		
24	2" - 4.5" WC - Brown, Plated Steel	1 655-697-002
	3.5" - 6.5" WC - Red, Plated Steel	1 655-697-003
	5"-9" WC - Black, Plated Steel	1 655-697-004
	6"-14" WC - Purple, Plated Steel	1 655-697-011
	8.5"-18" WC - Gray, Plated Steel	1 655-697-005
	14"-30" WC - Dark Green, Plated Steel	1 655-697-006
<b>Range Springs - High (H)</b>		
24	1 - 2 PSI - Dark Blue, Plated Steel	1 655-789-003
	1.5 - 3.25 PSI - Orange, Plated Steel	1 655-789-004
	2 - 5 PSI - Yellow, Plated Steel	1 655-789-005
<b>Diaphragm Assemblies</b>		
25	Nitrile - <b>L Only</b>	1 804-298-000
	Nitrile - <b>H Only</b>	1 804-298-002
26	Lower Casing - Aluminum	1 629-260-000

Item	Description	Part Number
27	Valve Stem assembly - Anodized Aluminum	1 827-013-000
<b>Seat Assemblies</b>		
28	Nitrile Seat Disk	1 822-033-000
29	Body/Lower Casing O-ring - Nitrile	1 649-309-012
<b>Orifices</b>		
30	1/4" Aluminum	1 688-016-000
	3/8" Aluminum	1 688-016-001
	1/2" Aluminum	1 688-016-002
	3/4" Aluminum	1 688-016-003
	1" Aluminum	1 688-016-004
	1-3/16" Aluminum	1 688-016-005
<b>Bodies</b>		
31	1-1/4" NPT - Iron	1 664-448-006
	1-1/2" NPT - Iron	1 664-448-002
	2" NPT - Iron	1 664-448-000
	2" x 1-1/2" - Iron	1 664-448-004
	2" 125FF - Iron	1 664-448-008
	1-1/4" NPT - Steel	1 664-448-007
	1-1/2" NPT - Steel	1 664-448-003
	2" NPT - Steel	1 664-448-001
	2" x 1-1/2" - Steel	1 664-448-005
	1-1/2" 150# RF Steel	1 664-448-009
2" 150# RF Steel	1 664-448-010	
32	Name Plate	1 632-526-000
33	Drive Screws	4 648-533-001

