

PFA Lined Plug Valves

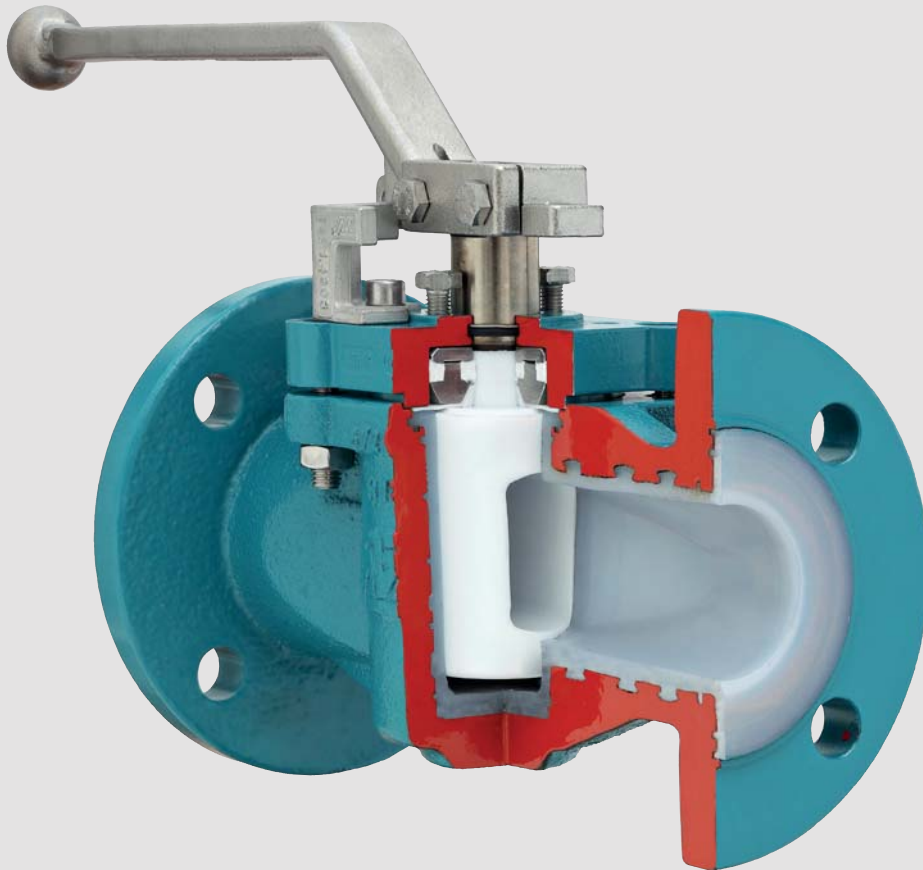

AZ lined plug valves

Design overview and options

chemically resistant lining

- minimum 3mm FEP/PFA lining
- anchorage of lining in body
- vacuum-capable

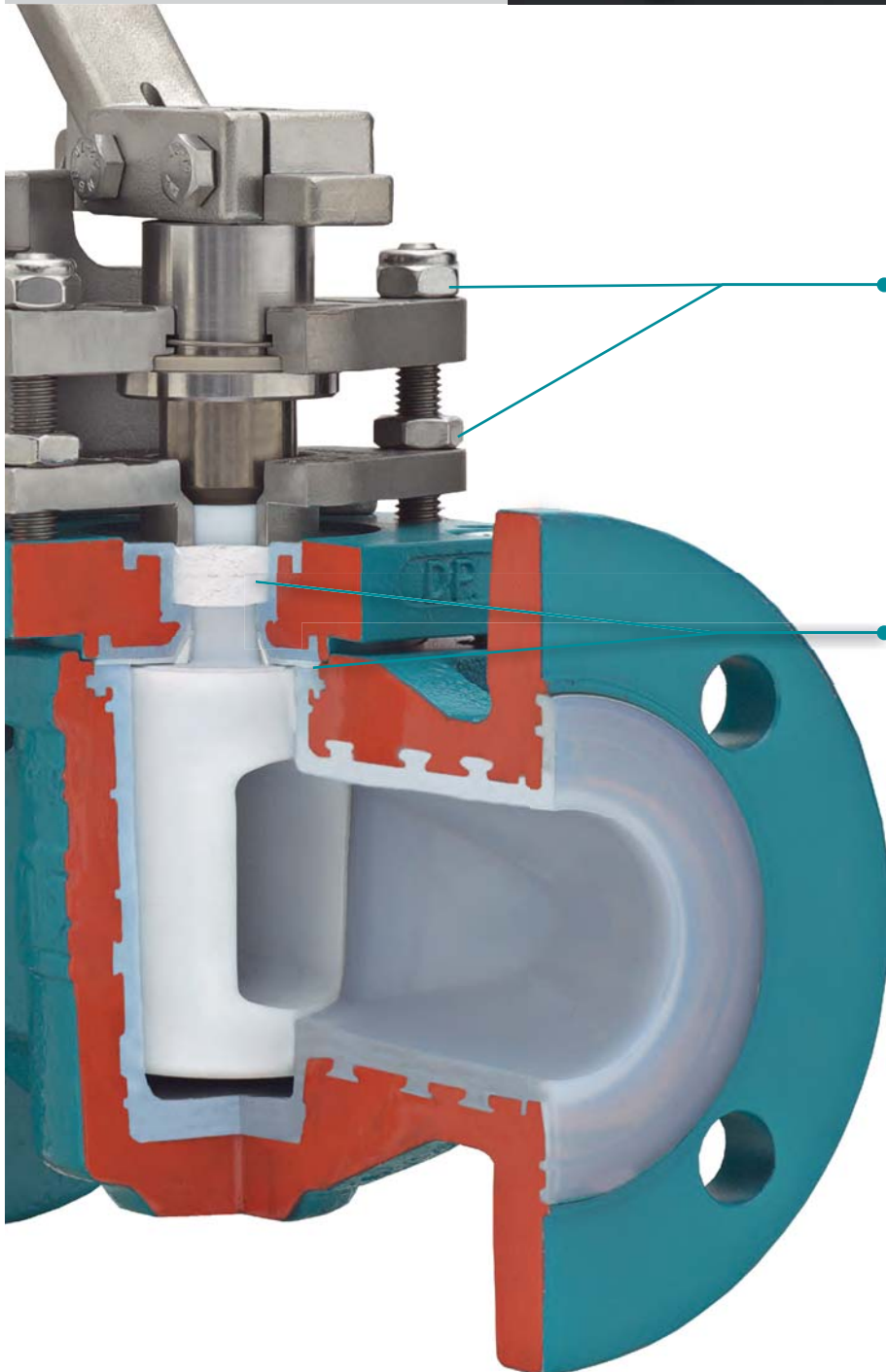

Type SAFE-LINED

for chemical applications with increased requirements

adjustable

- plug and stuffing box individually adjustable
- permanent accessibility guaranteed, also with mounted actuator / gearbox
- adjustable even under extreme operating conditions

Improved sealing

- cover fully PFA lined
- triple safety stem packing

*engineered.
fast.
dynamic.*

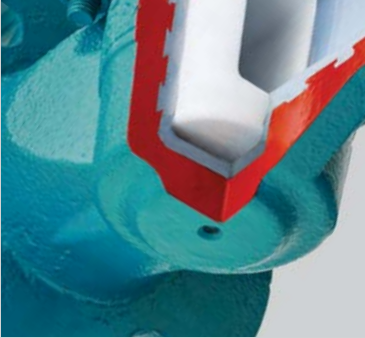

- weep holes for early leakage detection

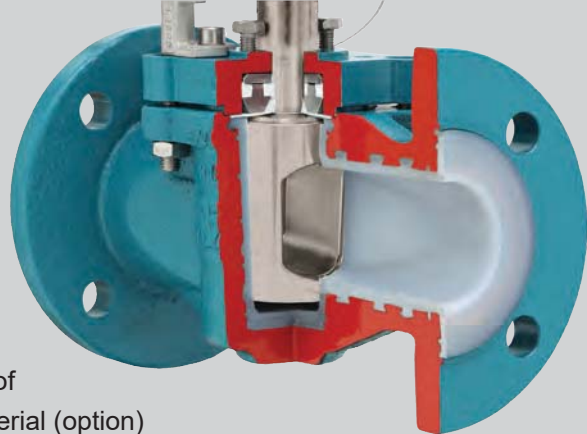

- plug made of special material (option)

Type ISO-STANDARD-A

- suitable for general chemical applications



- large range of plug types for horizontal and vertical 3-way lined plug valves

Type ISO-AB2000

- lined plug valve with exchangeable PTFE sleeve
- easy to repair



- heating jacket, full or partial design (option)

- two-way plug with flushing device (option)



Type ISO-STANDARD-A / SAFE-LINED

Lined plug valve



Type SAFE-LINED

- triple safety sealing system
- cover fully PFA lined

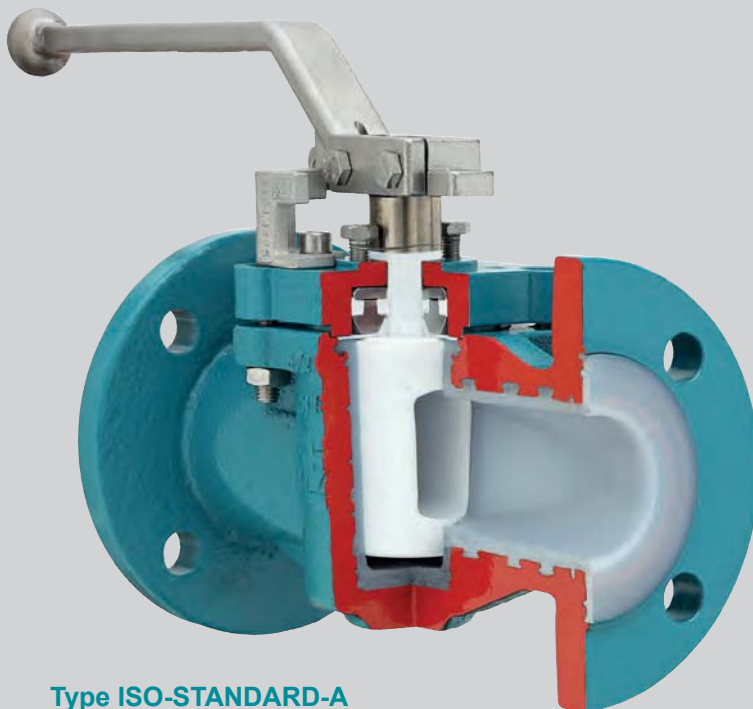

Type ISO-STANDARD-A

- full safety to operator and
- highest corrosion protection

DN 15 - 300 / PN 16 - 40
NPS ½ - 12 / class 150 - 300

Range of application:
-10 < T < 125/210°C
vacuum-capable

Design characteristics

- chemical-resistance
- free of cavities
- easy accessible adjustment of the plug
- mounting-flange for actuators acc. to ISO 5211
- plug lining
 - two-way plugs
 - ≤DN100 = PTFE
 - >DN100 = FEP or PFA lining
- body: Ductile Iron 5.3103, ASTM A395 or Carbon Steel 1.0619, ASTM A216 WCB

Options

- higher operating pressure
- heating jacket
- flushing device
- FDA compliant
- painting
- oil and grease-free assembly
- oversize design
- other materials



PT diagram, plug types, sealing systems, material selection: see catalogue part ENGINEERING

Flange dimensions acc. to DIN EN / ASME

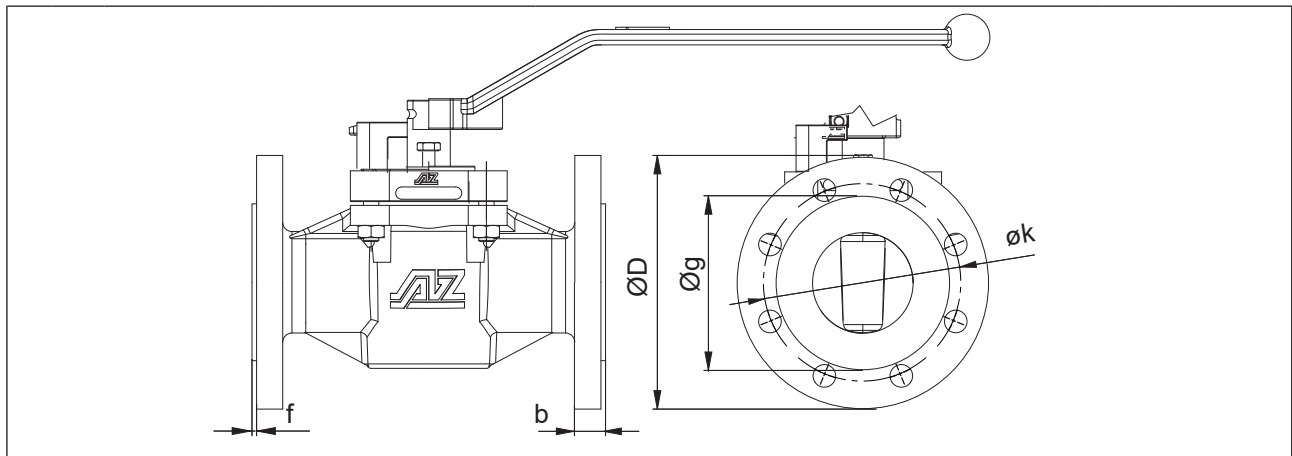

DIN EN 1092-1										ASME B16.5										
DN	PN	øD [mm]	flange bore [mm]		no.		ø [mm]	b [mm]	f [mm]	NPS	Class	øD [mm]	flange bore [mm]		no.		ø [mm]	øg [mm]	b [mm]	f [mm]
			øk									øk								
15	10-40	95	65	4	14	45	16	2	1/2	150	90	60,3	4	15,7	34,9	10,0				
20	10-40	105	75	4	14	58	18	2	3/4	300	95	66,7	4	15,7	42,9	10,9				
25	10-40	115	85	4	14	68	18	2	3/4	300	100	69,9	4	19,1	42,9	10,9				
32	10-40	140	100	4	18	78	18	2	1	300	115	82,5	4	19,1	42,9	16,3				
40	10-40	150	110	4	18	88	18	3	1	150	110	79,4	4	15,7	50,8	11,6				
50	10-40	165	125	4	18	102	20	3	1	300	125	88,9	4	19,1	50,8	17,9				
65	10-16		145	4/8	18	122	18	3	1 1/4	150	115	88,9	4	15,7	63,5	13,2				
	25-40	185		8	18	122	22	3	1 1/4	300	135	98,4	4	19,1	63,5	19,5				
80	10-40	200	160	8	18	138	24	3	1 1/2	150	125	98,4	4	15,7	73,0	14,7				
									1 1/2	300	155	114,3	4	22,3	21,1					
100	10-16	220	180	8	18	158	20	3	2	150	150	120,7	4	19,1	16,3					
	25-40	235	190		22	162	24	3	2	300	165	127,0	8	19,1	22,7					
125	10-16	250	210	8	18	188	22	3	2 1/2	150	180	139,7	4	19,1	17,9					
	25-40	270	220	8	26	188	26	3	2 1/2	300	190	149,3	8	22,3	25,9					
150	10-16	285	240	8	22	212	22	3	3	150	190	152,4	4	19,1	19,5					
	25-40	300	250	8	26	218	28	3	3	300	210	168,3	8	22,3	29,0					
200	10-16	340	295	8/12	22	268	24	3	4	150	230	190,5	8	19,1	24,3					
	25-40	360	375	12	26	278	285	30	4	300	255	200,0	8	22,3	32,2					
250	10-16	395	405	12	22	320	26	3	5	150	255	215,9	8	22,3	24,3					
	25-40	425	450	12	30	335	345	32	5	300	280	235	8	22,3	35,4					
300	10-16	445	460	12	22	370	378	26	6	150	280	241,3	8	22,3	25,9					
	25-40	485	515	16	30	395	410	34	6	300	320	269,9	12	22,3	37,0					
									10	150	405	362	12	25,4	30,6					
									10	300	445	387,4	16	28,4	48,1					
									12	150	485	431,8	12	25,4	32,2					
									12	300	520	450,8	16	31,7	51,3					

Type F-2 ISO-STANDARD-A / SAFE-LINED

Technical information DN 15 - 100 / NPS 1/2 - 4

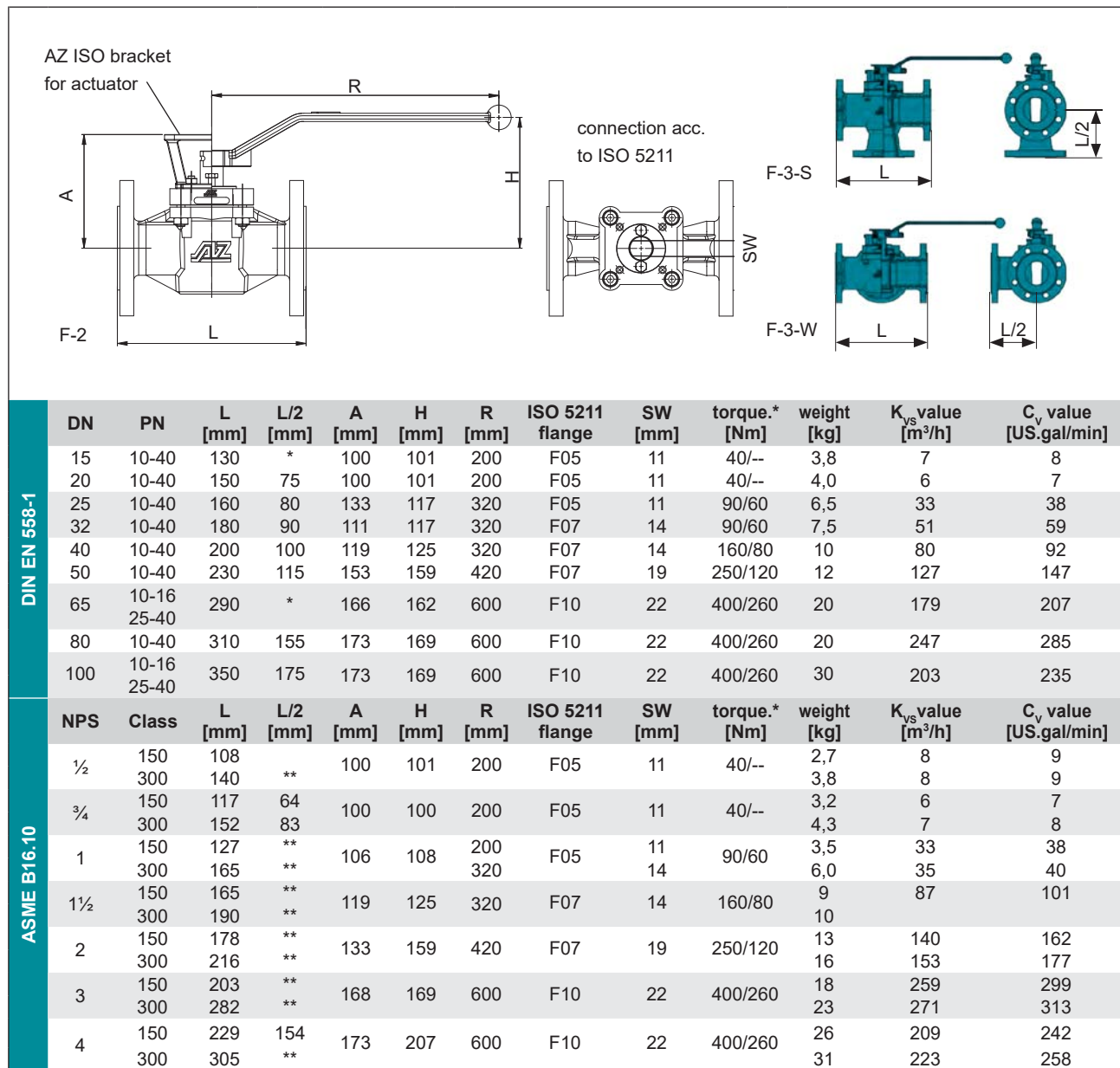

ISO flange instructions, weights and K_{vs} values for 2-way valves

*) Maximum breakaway torque $M_{d_{breakaway}} [Nm]$ for F-2 and F-3-S depending on material combinations (PFA+PFA / PFA+ PTFE)
 Manufacturer recommended sizing torque (incl. 100% safety)
 Breakaway torques for type F-3-W on request

***) on request

Some designs, sizes and/or configurations may be fitted with threaded flange holes.

Type F-2 ISO-STANDARD-A / SAFE-LINED

Technical information DN 100S - 300 / NPS 5 - 12

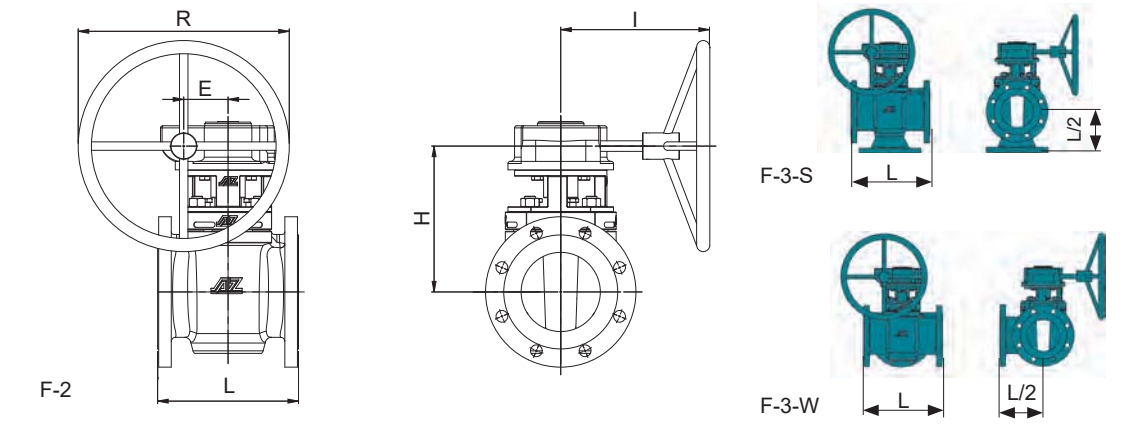

	DIN EN 558-1														
	DN	PN	L [mm]	L/2 [mm]	E [mm]	R [mm]	H [mm]	I [mm]	gear	AZ flange	SW [mm]	torque.* [Nm]	weight [kg]	K _{vs} value [m ³ /h]	C _v value [US.gal/min]
DIN EN 558-1	100S	10-16	350	**	84	500	207	290	Q1500-S	F16	36	600/350	32	447	517
		25-40		**									32		
	125	10-16	325	**	84	500	227	290	Q1500-S	F16	36	1200/900	74	359	414
		25-40		**									78		
	150	10-16	350	200	84	500	279	290	Q1500-S	F16	36	1200/900	85	823	951
		25-40											**		
200	10-16	400	**	96,5	500	321	350	Q3000-S	F16	36	2600/--	119	1728	1997	
	25 40		**									131			
250	10 16	450	**	117,5	500	352	465	Q5000-S	F16	36	3200/--	195	2053	2373	
	25 40		**									259			
300	10 16	500	**	117,5	500	340	465	Q5000-S	F16	36	3200/--	253	1707	1974	
	25 40		**									274			
	ASME B16.10														
	NPS	Class	L [mm]	L2 [mm]	E [mm]	R [mm]	H [mm]	I [mm]	gear	AZ flange	SW [mm]	torque.* [Nm]	weight [kg]	K _{vs} value [m ³ /h]	C _v value [US.gal/min]
4"S	150	254	154	84	500	230	328	Q1500-S	F16	36	600/350	27	492	569	
	300	325	**									32			508
6"	150	267	**	118	500	276	363	Q1500-S	F16	36	1200/900	66	789	912	
	300	403	**									77			904
8"	150	292	**	138	500	320	440	Q3000-S	F16	36	2600/--	103	1776	2053	
	300	419	**									138			1900
10"	150	330	**	138	500	352	440	Q5000-S	F16	36	3200/--	140	2257	2609	
	300	457	**									176			2465
12"	150	356	**	138	500	340	440	Q5000-S	F16	36	3900/--	168	1877	2170	
	300	502	*									187			2134

ISO flange instructions, weights and K_{vs} values for 2-way valves

*) Maximum breakaway torque $M_{d_{breakaway}} [Nm]$ for F-2 and F-3-S depending on material combinations (PFA+PFA / PFA+ PTFE)
 Manufacturer recommended sizing torque (incl. 100% safety)

Breakaway torques for type F-3-W on request

**) on request

Some designs, sizes and/or configurations may be fitted with threaded flange holes.

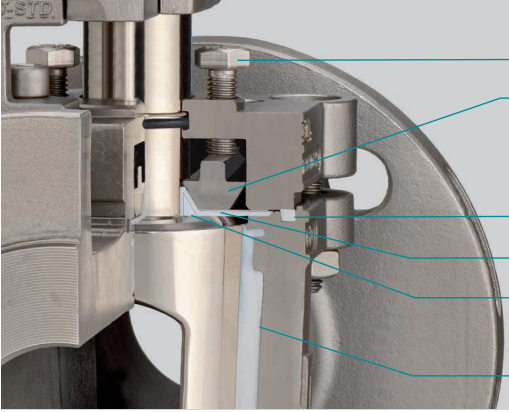
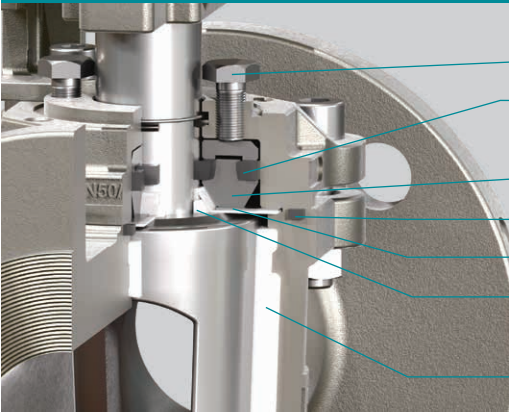
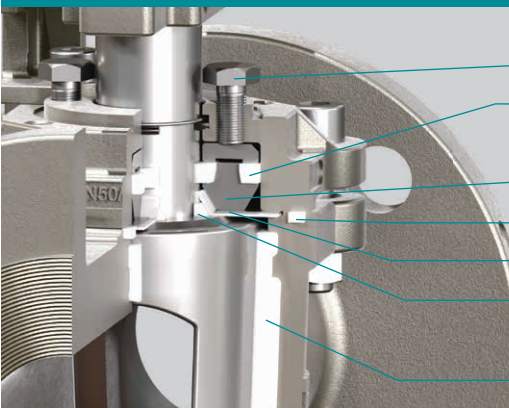

Cover and stem sealing systems suitable for general applications

	<p>Type STANDARD</p> <ul style="list-style-type: none"> ● plug adjustment ● thrust collar ● cover sealing (PTFE) ● stainless steel diaphragm ● Secondary sealing: V-diaphragm (PTFE), delta thrust collar (PTFE) ● Primary sealing: sleeve*
	<p>Type FS2 Fire-Safe-sealing (API 607)</p> <ul style="list-style-type: none"> ● plug & packing adjustment ● Tertiary sealing: Packing to atmosphere (graphite) ● thrust collar ● cover sealing (graphite) ● stainless steel diaphragm ● Secondary sealing: V-diaphragm (PTFE) and delta thrust collar (PTFE) ● Primary sealing: sleeve*
	<p>Type CA2 Chemistry sealing</p> <ul style="list-style-type: none"> ● plug & packing adjustment ● Tertiary sealing: Packing to atmosphere (PTFE) ● thrust collar ● cover sealing (PTFE) ● stainless steel diaphragm ● Secondary sealing: V-diaphragm, delta thrust collar (PTFE) ● Primary sealing: sleeve*

*) The sleeve material has a decisive influence on the maximum operating temperature
Material selection acc. to PT-diagram

More safety for severe applications

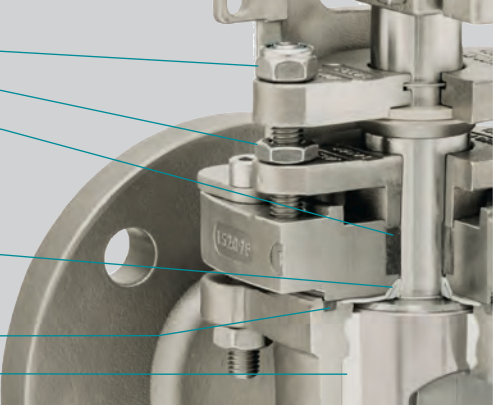
*engineered.
fast.
dynamic.*

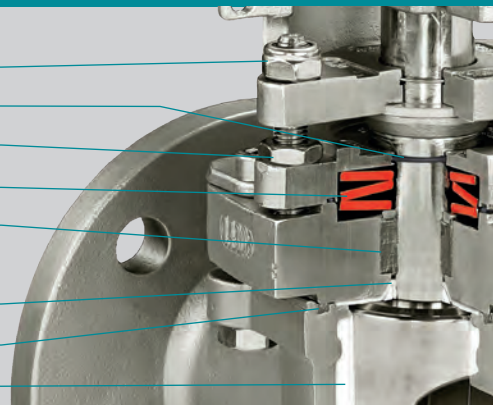
Type FSN	Fire-Safe-sealing (API 607)
<p>plug adjustment</p> <p>triple safety stem packing adjustment</p> <p>Tertiary sealing: triple safety stem packing (graphite)</p> <p>Secondary sealing: V-diaphragm (PTFE) and delta thrust collar (PTFE)</p> <p>cover sealing (graphite)</p> <p>Primary sealing: sleeve*</p>	
<p>Type FSN-EF</p> <p>Emission Free</p> <p>plug adjustment</p> <p>triple safety stem packing adjustment</p> <p>Quaternary sealing: three o-rings at the stem</p> <p>Tertiary sealing: triple safety stem packing</p> <p>Secondary sealing: V-diaphragm (PTFE) and delta thrust collar (PTFE)</p> <p>cover sealing (graphite)</p> <p>Primary sealing: sleeve*</p>	<p>NEW!</p> 
<p>Type FSN-SL</p> <p>live-loaded</p> <p>plug adjustment</p> <p>o-rings protect the springs against corrosion</p> <p>triple safety stem packing adjustment</p> <p>disk springs (optionally made of Inconel)</p> <p>Tertiary sealing: triple safety stem packing (graphite)</p> <p>Secondary sealing: V-diaphragm (PTFE) and delta thrust collar (PTFE)</p> <p>cover sealing (graphite)</p> <p>Primary sealing: sleeve*</p>	

*) The sleeve material has a decisive influence on the maximum operating temperature
Material selection acc. to PT-diagram

Material for **type CASN** and **CASN-SL** chemistry safety sealing: packing and cover sealing in PTFE

Special sealing systems

Chevron packing

- increases the contact pressure (when pressure builds up on the safety stem packing towards plug stem)
- for toxic and fugitive media
- high wear resistance



Type CL Chlorine / gas applications

- approved for chlorine applications and other toxic gases
- ideal for media with changing state of aggregate (e.g. liquid to gas, vice versa)
- vacuum capable



Detection ports for monitoring purpose of lethal gases (phosgene, etc.)

- detection ports for early recognition of potential leakages
- sniffing at sealing surfaces to atmosphere

stem packing

cover sealing

flange sealing



Cover and stem sealing systems for lined plug valves

*engineered.
fast.
dynamic.*

Type CA	Chemistry sealing		
<p>plug & packing adjustment</p> <p>Tertiary sealing: Packing to atmosphere (PTFE)</p> <p>thrust collar</p> <p>stainless steel diaphragm</p> <p>Secondary sealing: V-diaphragm & delta thrust collar (PTFE)</p> <p>Primary sealing: lined body</p>			
	Type SAFE-LINED	Chemistry sealing	
	<p>lined cover</p> <p>plug adjustment</p> <p>triple safety stem packing adjustment</p> <p>Tertiary sealing: triple safety stem packing (PTFE) to atmosphere</p> <p>Secondary sealing: V-diaphragm (PTFE), delta thrust collar (PTFE)</p> <p>lined cover</p> <p>Primary sealing: lined body*</p>		
		Type SAFE-LINED-SL	Chemistry sealing
		<p>live-loaded</p> <p>plug adjustment</p> <p>o-rings protect the springs against corrosion</p> <p>triple safety stem packing adjustment</p> <p>disk springs (optionally made of Inconel)</p> <p>Tertiary sealing: triple safety stem packing (PTFE) to atmosphere</p> <p>Secondary sealing: V-diaphragm (PTFE), delta thrust collar (PTFE)</p> <p>lined cover</p> <p>Primary sealing: lined body*</p>	

*) Lining and plug material have a decisive influence on the maximum operating temperature
Material selection according to PT-diagram.

Casting materials



Material Group	Common Name	Casting Material					
		EN / DIN	Short name	Material-No.	ASTM	Grade	UNS
Carbon Steel / Ductile Iron							
Ductile Iron	SG Iron	EN 1563	EN-GJS-400-18-LT	5.3103	A395	-	F32800
Carbon Steel	CS	EN 10213	GP240GH	1.0619	A216	WCB	J03002
Low Temp. Carbon Steel	LTCS	EN 10213	G17Mn5	1.1131	A352	LCB	J03003
Low Temp. Carbon Steel	LTCS	EN 10213	G21Mn5	1.1138	A352	LCC	J02505
Stainless Steel							
Stainless Steel	Duplex 2205	EN 10213	GX2CrNiMoN22-5-3(4A)	1.4470	A995	4A-CD3MN	J92205
Stainless Steel	Duplex 1B	EN 10213	GX3NiCrMoCuN26-6-3-3	1.4517	A995	1B-CD4MCuN	J93372
Austenitic	SS	EN 10213	GX5CrNi19-10	1.4308	A351	CF8	J92600
Austenitic	SS	EN 10213	GX2CrNi19-11	1.4309	A351L	CF3	J92700
Austenitic	SS	EN 10213	GX5CrNiMo19-11-2	1.4408	A351	CF8M	J92900
Austenitic	SS	EN 10213	GX2CrNiMo19-11-2	1.4409	A351	CF3M	J92800
Super Austenitic	Alloy 20	EN 10213	NiC420CuMo	1.4500	A351	CN7M	N08007
Super Austenitic	Alloy 20 mod.	EN 10213	GX2NiCrMoCuN25-20	1.4536	A743	CN7MS	J94650
Super Austenitic	AL6XN	-	-	-	A351	CN3MN	J94651
Superduplex	Superduplex 5A	EN 10213	25Cr-7Ni-Mo-N	1.4469	A995	CE3MN	J93404
Nickel Alloy							
	Monel/Alloy400	DIN 17730	G-NiCu30 Nb	2.4365	A494	M35-1	N24135
	Hastelloy C mod.	-	-	-	A494	CW6M	N30107
	Hastelloy C	-	-	2.4537	A494	CW12MW	N30002
	Hastelloy C-276	-	-	2.4883	-	-	-
	Hastelloy B-3	-	-	-	-	-	-
	Inconel 600	-	-	-	A494	CY40	N06040
	Inconel 625	-	-	-	A494	CW6MC	N26625
	Inconel 825	-	-	-	A494	CU5MCuC	N08826
	Nickel	DIN 17730	G-Ni 95	2.4170	A494	CZ100	N02100
Other Material Groups							
Tantalum	Tantalum	-	-	-	-	-	-
Titanium	Ti 2	DIN 17865	G-Ti 2	3.7031	B367	C-2	R52550
Zirconium	Zirconium 702	-	-	-	B752	702C	-
Zirconium	Zirconium 705	-	-	-	-	705C	-

All rights reserved, all indications without engagement, subject to modifications.

The use of these equivalents has to be evaluated on a case-by-case basis.

Other materials on request.

Equivalent forged and bar-stock materials

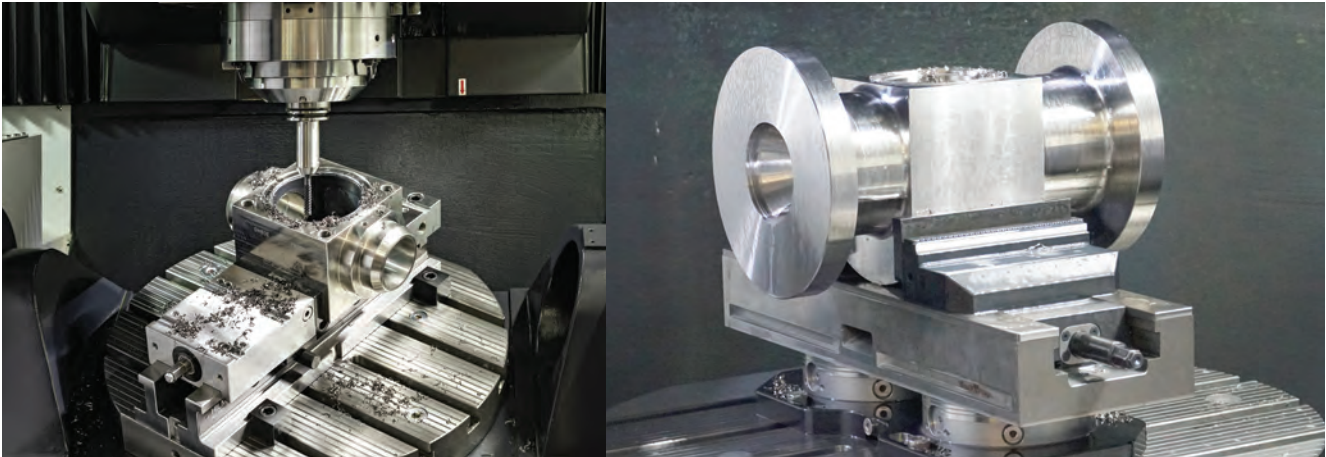

Common Name	Mat.Nr.	Grade	Similar Forged Material						Bar Material	
			EN / DIN	Short Name	Mat.Nr.	ASTM	Grade	UNS	ASTM Short	
Carbon Steel / Ductile Iron										
SG Iron	5.3103	-	EN 1563	EN-GJS-400-18-LT	5.3103	A395-99	60-40-18	-	-	-
CS	1.0619	WCB	EN 10213	GP240GH	1.0619	A105	A105	-	-	-
LTCS	1.1131	LCB	-	-	-	A350	LF2-Class1	G10300	-	-
LTCS	1.1138	LCC	-	-	1.0566	A350	LF2-Class1	G10250	-	-
Stainless Steel										
Duplex 2205	1.4470	4A-CD3MN	EN 10028-7	X2CrNiMoN22-5-3	1.4462	A182	F51	S32205	A479	S31803
Duplex 1B	1.4517	1B-CD4MCuN	EN 10028-7	X2CrNiMoCuN25-5-3	1.4507	A182	F59	S32520	A479	S32550
SS	1.4308	CF8	EN 10028-7	X5CrNi18-10	1.4301	A182	F304	S30400	A276	304
SS	1.4309	CF3	EN 10028-7	X2CrNi19-11	1.4306	A182	F304L	S30403	A276	304L
SS	1.4408	CF8M	EN 10028-7	X5C4NiMo17-12-2	1.4401	A182	F316	S31600	A276	316
SS	1.4409	CF3M	EN 10028-7	X2CrNiMo 17-12	1.4404	A182	316L	S31603	A276	316L
Alloy 20	1.4500	CN7M	-	-	2.4660	B462	N08020	N08020	B473	N08020
Alloy 20 mod.	1.4536	CN7MS	-	-	-	-	-	-	-	-
AL6XN	-	CN3MN	EN 10028-7	X1NiCrMoCuN25-20-7	1.4529	A182	F62	N08367	B462	N08367
Superduplex 5A	1.4469	CE3MN	EN 10028-7	X2CrNiMoN25-7-4	1.4410	A182	F63	S32615	-	-
Nickel Alloy										
Monel/Alloy400	2.4365	M35-1	DN 17744	NiCu30Fe	2.4360	B165	Alloy 400	N04400	B164	N04400
Hastelloy C mod.	-	CW6M	-	-	-	A494	-	-	-	-
Hastelloy C	-	CW12MW	-	NiMo16CrW	-	A494	-	-	-	-
Hastelloy C-276	-	-	DIN 17744	NiMo16Cr15W	2.4819	B565	N10675	N10276	B574	N10276
Hastelloy B-3	-	-	DIN 17744	NiMo29Cr	2.4600	B565	N10675	N10675	B335	N10675
Inconel 600	-	CY40	DIN 17742	NiCr15Fe	2.4816	B565	N06600	N06600	B166	N06600
Inconel 625	-	CW6MC	DIN 17744	NiCr22Mo9Nb	2.4856	B565	N06625	N06625	B446	N06625
Inconel 825	-	CU5MCuC	DIN 17744	NiCr21Mo	2.4858	B564	N08825	N08825	B425	N08825
Nickel	2.4170	CZ100	-	-	-	-	-	-	B160	N02200
Other Material Groups										
Tantalum	-	-	-	-	-	B365	TaW2,5	R05252	-	-
Ti 2	3.7031	C-2	DIN 17864	Grade 2	3.7035	B381	F2	R50400	B348	Grade 2
Zirconium 702	-	702C	-	-	6.0702	B493	R60702	R60702	B550	R60702
Zirconium 705	-	705C	-	-	-	B493	R60705	R60705	B550	R60705

All rights reserved, all indications without engagement, subject to modifications.

The use of these equivalents has to be evaluated on a case-by-case basis.

Other materials on request.

Lining materials



Lining materials

The high density, extremely resistant lining is at least 3 mm thick. New granulate is used exclusively, no refurbished regenerates or similar materials.

Fluoropolymer lining materials

- Body: PFA, PFA conductive and FEP
- Plug: PTFE, PFA, PFA conductive and FEP

body lining	Combination of linings plug lining	T _{max}
PFA	PTFE ¹⁾ or special materials	210°C / 410°F
PFA	PFA	200°C / 392°F
PFA	FEP	150°C / 302°F
PFA conductive	PFA conductive	125°C / 257°F
FEP	FEP	150°C / 302°F
FEP	PFA	150°C / 302°F

- 1) Plugs with PTFE lining only for two-way valves up to DN 100.
Plugs for multi-way valves not with PTFE lining available.

IMPORTANT NOTE

For demanding conditions, such as process temperatures exceeding 150°C / 302°F: Valve size, media phase, plug position & temperature (constant or fluctuating) may have an impact on the lifetime. Consult factory for proper selection of lining material, cover sealing type and special features.

Sleeve materials



Category	Sleeve Material	Characteristics	Typical applications	T _{MAX}
PTFE	PTFE, virgin	low friction, very good sealing characteristic	standard sleeve material for most applications	230°C / 446°F
RPTFE	PTFE-Glass	reinforced PTFE	additional stability for multiway valves with horizontal ports	230°C / 446°F
	PTFE-Graphite	reinforced PTFE	high temperature applications	250°C / 482°F
modified PTFE	TFM 1600* NXT 75* M 111*	chemically modified PTFE, reduced permeation, low friction	chemical applications where reduced permeability compared to PTFE is required	250°C / 482°F
Special Sleeves	PTFE-P* NFCE* NCS*	high performance sleeve materials	severe service highest temperatures, high pressure, abrasive applications	320°C / 608°F
PFA	PFA	reduced permeation	chemical applications where reduced permeability compared to PTFE is required	200°C / 392°F
UHMW-PE	UHMW-PE	Ultra High Molecular Weight Polyethylene	radiation resistant, abrasive application	80°C / 176°F

*) sleeve material selection depending on availability at AZ manufacturing site

IMPORTANT NOTE

for demanding conditions, such as process temperatures exceeding 200°C / 392°F:
Valve size, media phase, plug position & temperature (constant or fluctuating) may have an impact on the lifetime. Consult factory for proper selection of sleeve material, cover sealing type and special features. For other sleeve materials not listed above: please contact your AZ sales representative.

PT Diagram, PN 16 - PN 100

PTFE sleeved plug valves

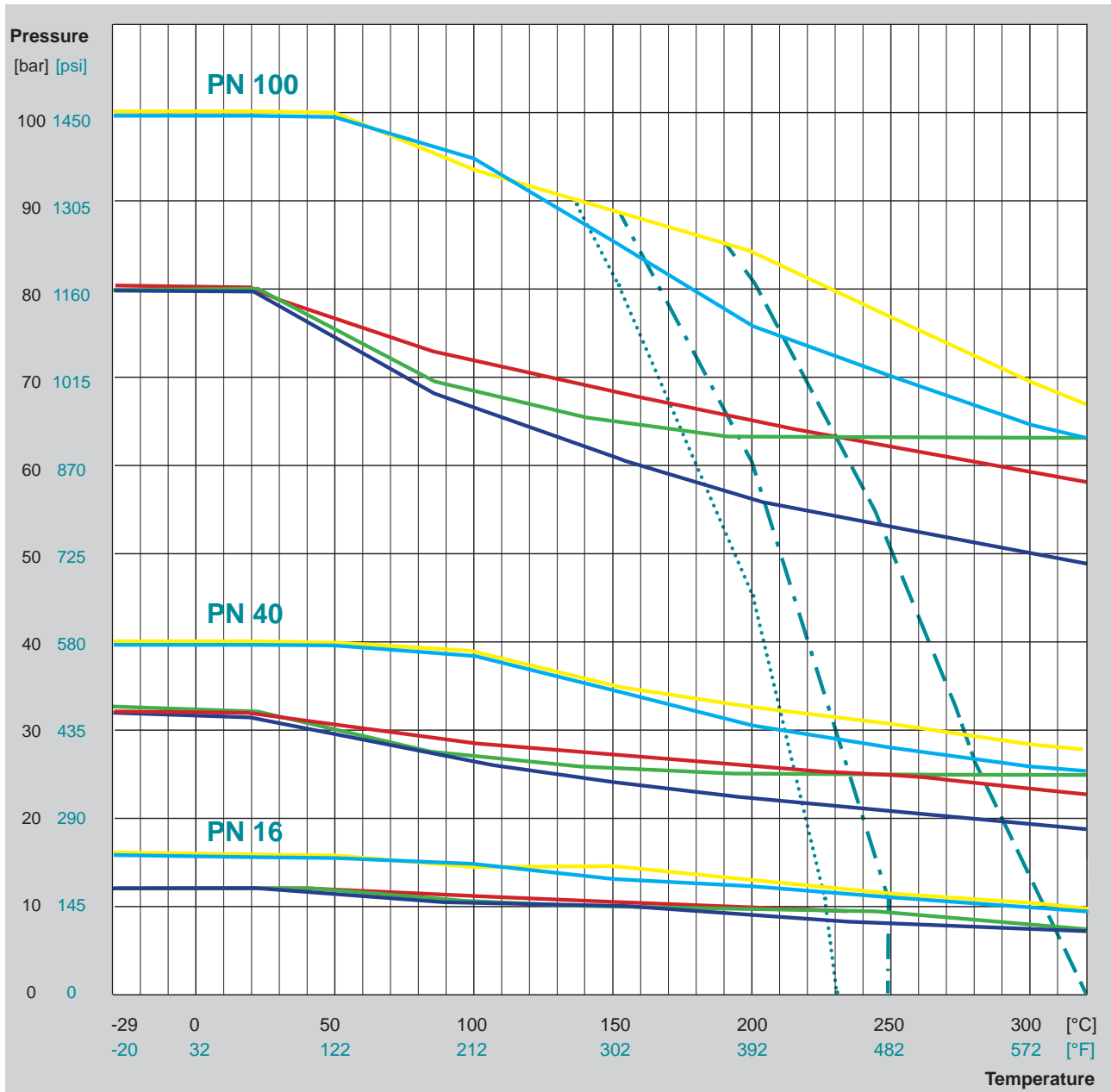

Body material

- Carbon Steel (Yellow)
 - Stainless Steel (Light Blue)
 - Hastelloy (Red)
 - Monel 400 (Green)
 - Alloy 20 (Dark Blue)
- other body materials on request

Sleeve material

- PTFE (virgin) / PTFE (glass) T_{max} 230°C / 446°F
 - .-.- TFM / NXT / M111 / PTFE graphite T_{max} 250°C / 482°F
 - PTFE-P / NFCE / NCS T_{max} 320°C / 608°F
- other sleeve materials on request

The data given are max. values according to EN 12516-1 and EN 1092-1.

IMPORTANT NOTE

for demanding conditions, such as process temperatures exceeding 200°C / 392°F: Valve size, media phase, plug position & temperature (constant or fluctuating) may have an impact on the lifetime. Consult factory for proper selection of sleeve material, cover sealing type and special features.

For temperatures < -29°C / -20°F, ($T_{limit} = -60°C / -76°F$) operating temperature, low-temperature carbon steel or austenitic stainless steels are required.

Subject to technical change without notice.

PT Diagram, Class 150 - Class 600

PTFE sleeved plug valves

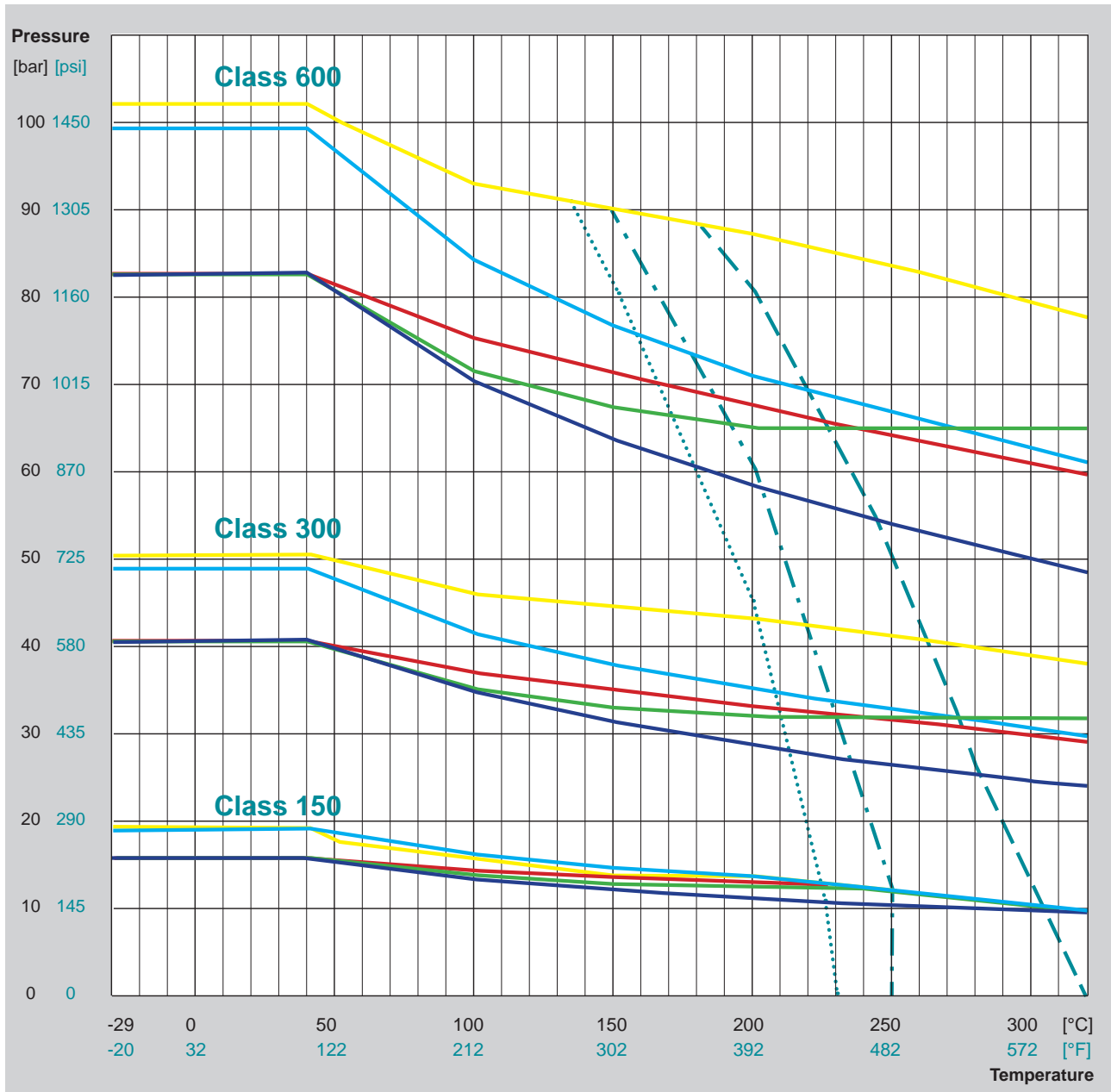

Body material

- ASTM A216 - WCB
- ASTM A351 - CF8M
- ASTM A494 - CW12MW / Hastelloy
- ASTM A494 - M35.1 / Monel 400
- ASTM A351 - CN7M Alloy 20
- other body materials on request

Sleeve material

- PTFE (virgin) / PTFE (glass) T_{max} 230°C / 446°F
- .-.- TFM / NXT / M111 / PTFE graphite T_{max} 250°C / 482°F
- PTFE-P / NFCE / NCS T_{max} 320°C / 608°F
- other sleeve materials on request

The data given are max. values according to ASME B16.34.

IMPORTANT NOTE

for demanding conditions, such as process temperatures exceeding 200°C / 392°F: Valve size, media phase, plug position & temperature (constant or fluctuating) may have an impact on the lifetime. Consult factory for proper selection of sleeve material, cover sealing type and special features.

For temperatures < -29°C / -20°F, ($T_{limit} = -60°C / -76°F$) operating temperature, low-temperature carbon steel or austenitic stainless steels are required.

Subject to technical change without notice.

PT Diagram High Pressure, PN 160

PTFE sleeved plug valves with trunnion mounted design

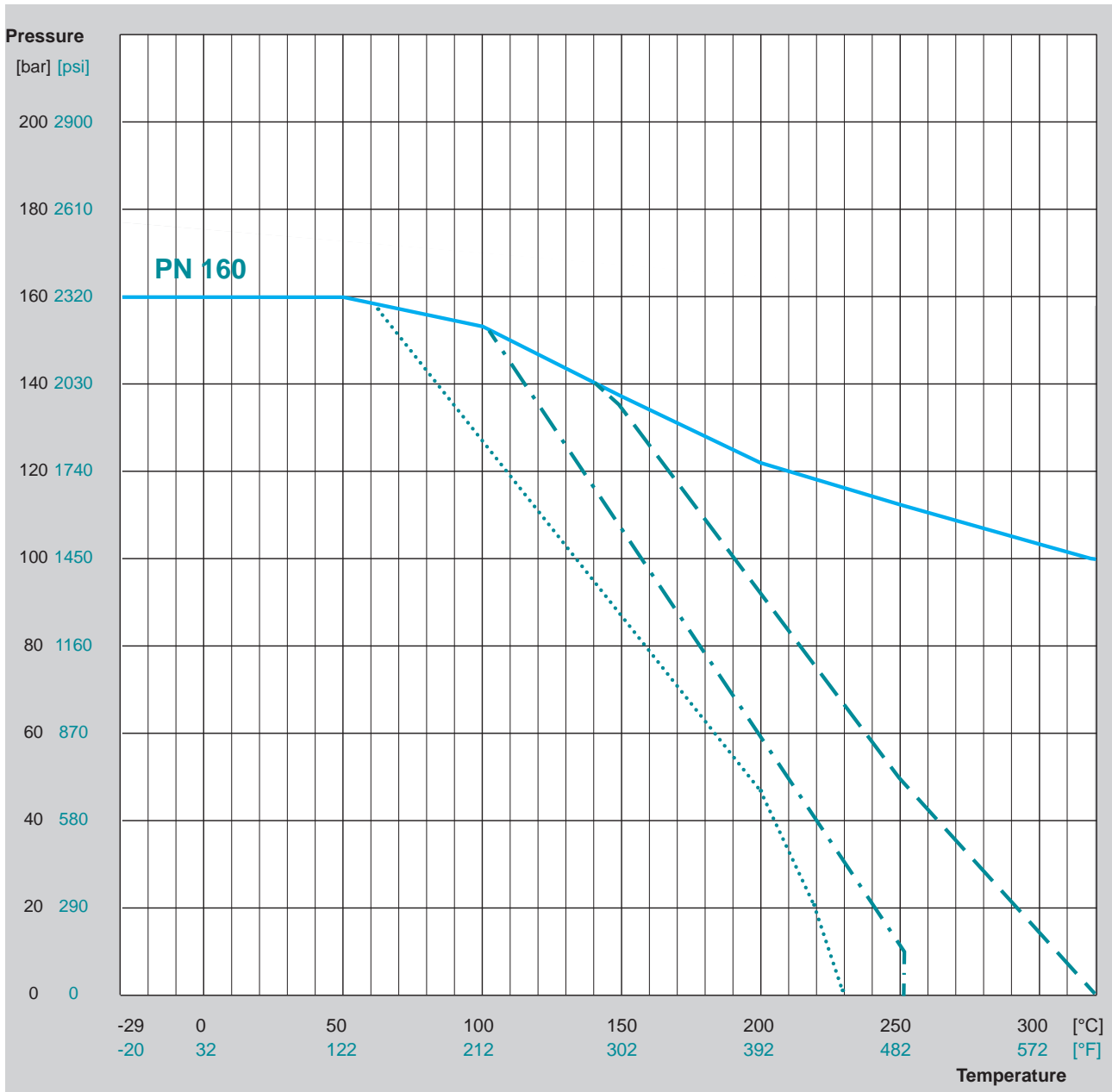

Body material (in line with EN 12516-1 and EN 1092-1)

- EN 10213 - 1.4408 / Stainless Steel
- other body materials on request

Sleeve material

- PTFE (virgin) / PTFE (glass) T_{max} 230°C / 446°F
- . - . TFM / NXT / M111 / PTFE graphite T_{max} 250°C / 482°F
- PTFE-P / NFCE / NCS T_{max} 320°C / 608°F
- other sleeve materials on request

The data given are max. values according to EN 12516-1 and EN 1092-1.

IMPORTANT NOTE

for demanding conditions, such as process temperatures exceeding 200°C / 392°F: Valve size, media phase, plug position & temperature (constant or fluctuating) may have an impact on the lifetime. Consult factory for proper selection of sleeve material, cover sealing type and special features.

For temperatures < -29°C / -20°F, ($T_{limit} = -60°C / -76°F$) operating temperature, low-temperature carbon steel or austenitic stainless steels are required.

Subject to technical change without notice.

PT Diagram High Pressure, Class 900

PTFE sleeved plug valves with trunnion mounted design

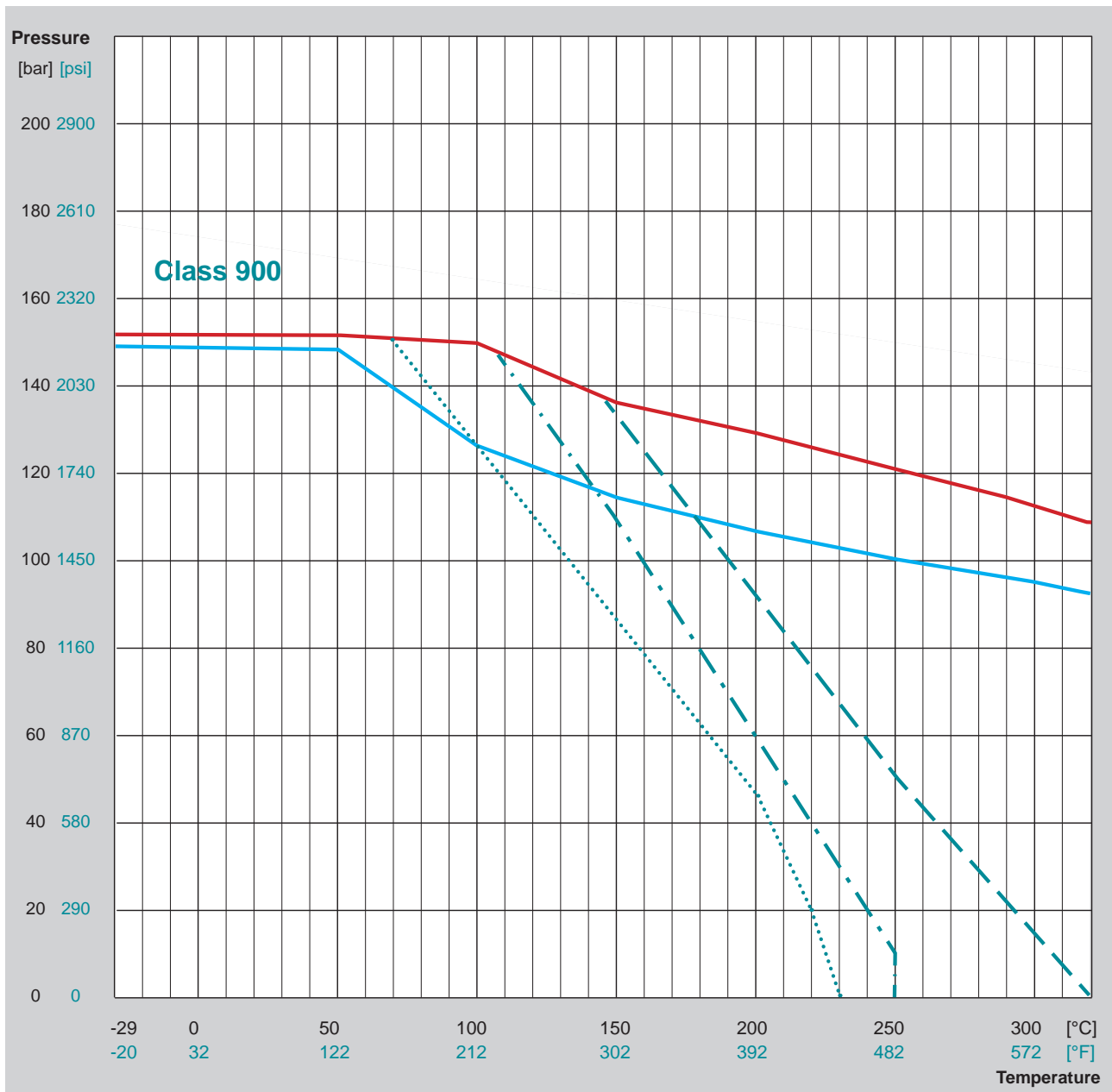

Body material (in line with ASME B16.34)

- ASTM A351 - CF8M / Stainless Steel
- ASTM A995 - CD3MN / Superduplex
- other body materials on request

Sleeve material

- ⋯⋯⋯ PTFE (virgin) / PTFE (glass) T_{max} 230°C / 446°F
- · - · - TFM / NXT / M111 / PTFE graphite T_{max} 250°C / 482°F
- - - PTFE-P / NFCE / NCS T_{max} 320°C / 608°F
- other sleeve materials on request

The data given are max. values according to ASME B16.34.

IMPORTANT NOTE

for demanding conditions, such as process temperatures exceeding 200°C / 392°F: Valve size, media phase, plug position & temperature (constant or fluctuating) may have an impact on the lifetime. Consult factory for proper selection of sleeve material, cover sealing type and special features.

Subject to technical change without notice.

For temperatures < -29°C / -20°F, ($T_{limit} = -60°C / -76°F$) operating temperature, low-temperature carbon steel or austenitic stainless steels are required.

PT Diagram, PN 10 - PN 40 lined valves

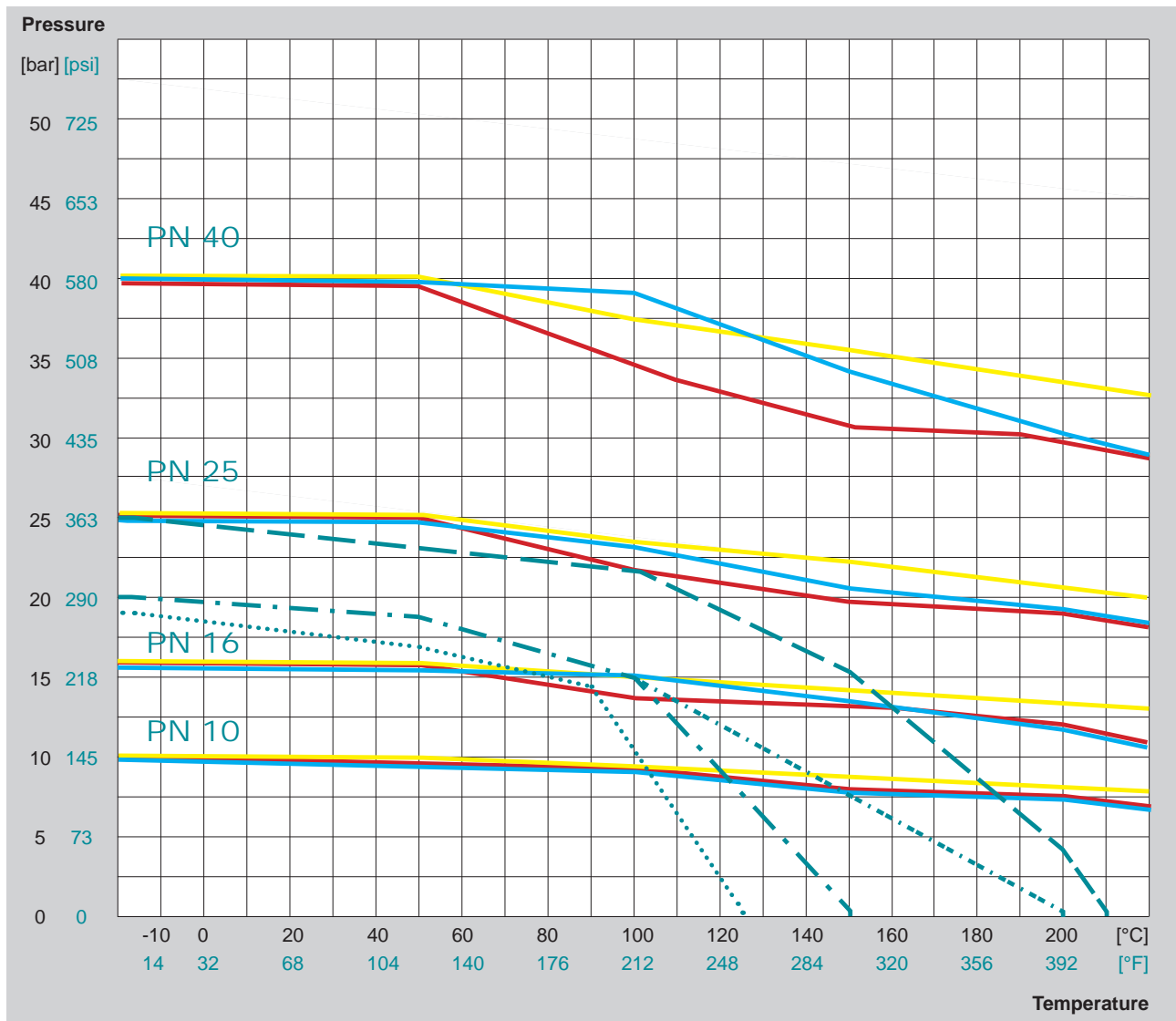

Body material

- EN 10213 - 1.0619 / Carbon Steel
 - EN 10213 - 1.4408 / Stainless Steel
 - EN 1563 - EN-GJS-400-18-LT / Ductile Iron
- other body materials on request

Lining combination

	Body	Plug / Ball	T _{MAX}
- - -	PFA	PTFE or special*	210°C / 410°F
.	PFA	PFA	200°C / 392°F
- . - . -	all combinations with PFA and FEP		150°C / 302°F
.	PFA conductive	PFA conductive**	125°C / 257°F

*) Special materials (metallic) for plugs without lining on request

**) Material combination PFA / FEP possible

The data given are max. values according to EN 12516-4.

IMPORTANT NOTE

for demanding conditions, such as process temperatures exceeding 150°C / 302°F: Valve size, media phase, plug position & temperature (constant or fluctuating) may have an impact on the lifetime. Consult factory for proper selection of lining material, cover sealing type and special features.

Maximum breakaway torque depending on material combinations according to the technical data sheets of the plug valve.

Subject to technical change without notice.

PT Diagramm, Class 150 - Class 300 lined valves

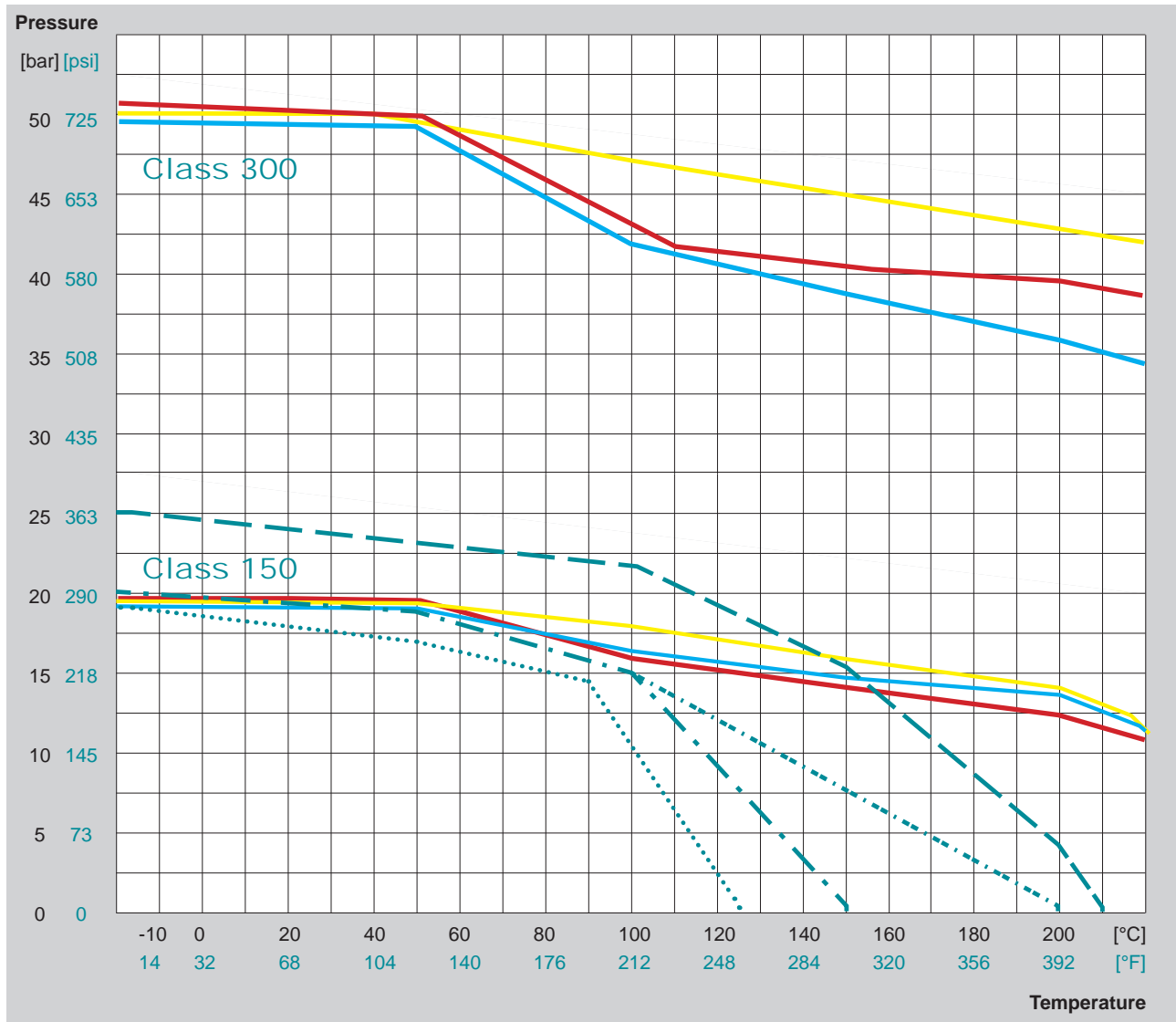

Body material

- ASTM A216 - WCB
- ASTM A351 - CF8M / Stainless Steel
- ASTM A395 / Ductile Iron
- other body materials on request

Lining combination

	Body	Plug / Ball	T _{MAX}
- - -	PFA	PTFE or special*	210°C / 410°F
.	PFA	PFA	200°C / 392°F
- . - . -	all combinations with PFA and FEP		150°C / 302°F
.	PFA conductive	PFA conductive**	125°C / 257°F

*) Special materials (metallic) for plugs without lining on request

***) Material combination PFA / FEP possible

The data given are max. values according to EN 12516-4.

IMPORTANT NOTE

for demanding conditions, such as process temperatures exceeding 150°C / 302°F: Valve size, media phase, plug position & temperature (constant or fluctuating) may have an impact on the lifetime. Consult factory for proper selection of lining material, cover sealing type and special features.

Maximum breakaway torque depending on material combinations according to the technical data sheets of the plug valve.

Subject to technical change without notice.

Plug types: two-way and multi-port for standard reduced and full bore design



- position indicator for all multi-way valves welded on lever or stem extension
- Lined plug valves: multi-way plugs only with PFA / FEP plug lining or made of special materials. Two-way plugs with PTFE lining up to DN 100 / NPS 4 available

Recommendation for three-way valves type F-3-S with vertical outlet (longer life-time compared to type F-3-W with horizontal outlet)

Options

Plugs made of special materials or special designs, e.g. with flushing devices, vent holes in plug bottom or plug upstream / downstream side





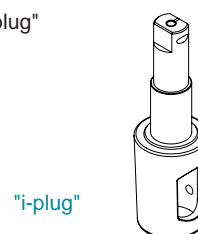

2-way	Plug type	Pos. I = 0°	Pos. II = 90°	Pos. III = 180°	Pos. IV = 270°
	D 				
Type F-2-ISO-STANDARD	T4 * 				



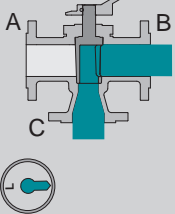
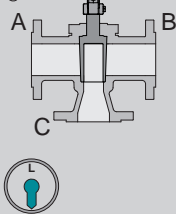
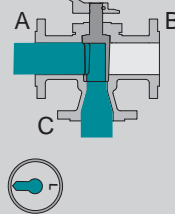

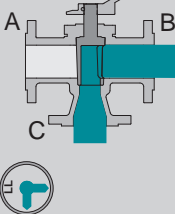
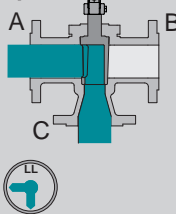

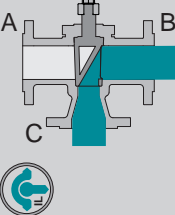
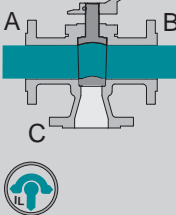
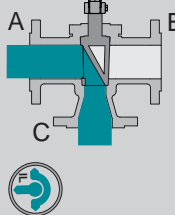
*) For highly expanding media AZ recommends the "i-plug" (relief hole and open plug bottom)

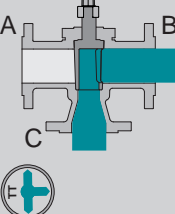
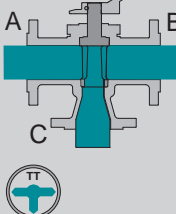
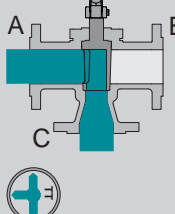

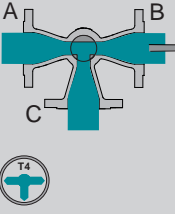
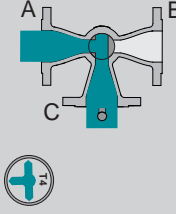
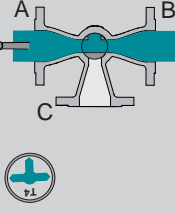
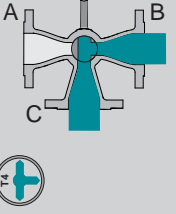
Plug types: 3-way valve for STANDARD and EXTRA design

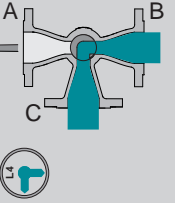
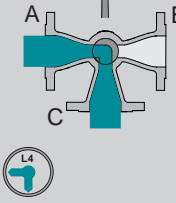
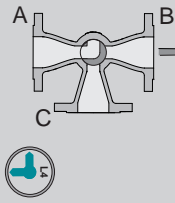
Plug type	Pos. I = 0°	Pos. II = 90°	Pos. III = 180°	Pos. IV = 270°	3-way (vertical)
L 					 Type F-3-S-ISO-STANDARD
LL 					
IL* 					 Type F-3-S-ISO-STANDARD-A
TT 					

Plug type	Pos. I = 0°	Pos. II = 90°	Pos. III = 180°	Pos. IV = 270°	3-way (horizontal)
T4 					 Type F-3-W-ISO-STANDARD
L4 					 Type F-3-W-ISO-STANDARD-A

*) for EXTRA valves with IL-plug, F-3-W-EXTRA with T4-plug is recommended (higher flowrate)
Lined valves: the IL-plug is only available in special materials

Plug types 3-way (120°) valves and 4-way valves for STANDARD and EXTRA design

3-way (120°) type 3-W-120:

- min. cross section guaranteed (switching phase)
- piggable execution on request
- minimum flow guaranteed

transflow design

3-way (120°) type 3-WP-120

- with positive overlap
- flow interruption / isolation











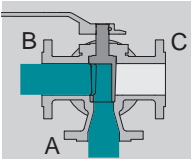
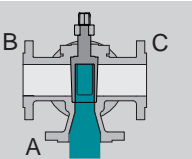
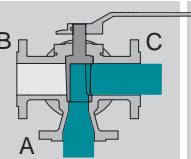
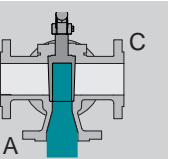

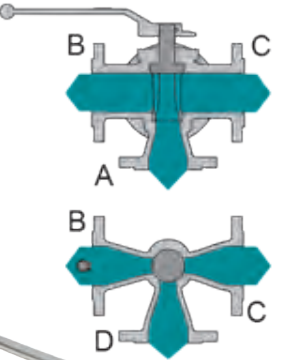
positive overlap

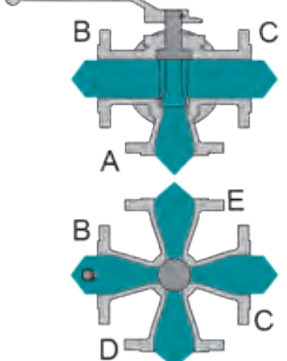

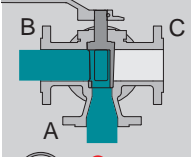
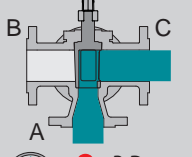
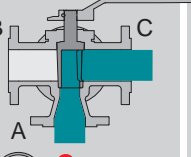
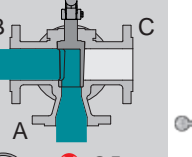
3-way (120°)	Plug type	Pos. I = 0°	Pos. II = 120°	Pos. III = 240°	
	L120 				

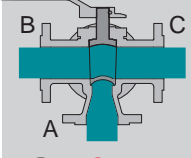
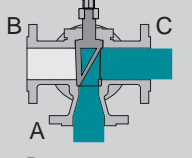
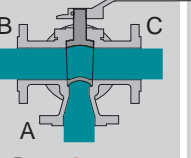
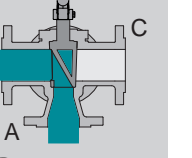
4-way	Plug type	Pos. I = 0°	Pos. II = 90°	Pos. III = 180°	Pos. IV = 270°
 Type F-4-ISO-STANDARD 	L4 	 ✓ B-E ✗ C-D	 ✗ B-D ✓ C-E	 ✗ B-E ✓ C-D	 ✗ C-E ✓ B-D
	T4 	 ✗ D ✓ B-C-E	 ✗ B ✓ C-D-E	 ✗ E ✓ B-C-D	 ✗ C ✓ B-D-E
	LL4 	 ✓ B-E + C-D	 ✓ B-D + C-E		

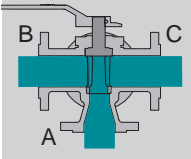
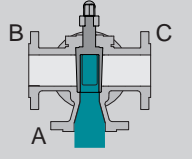
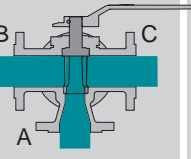
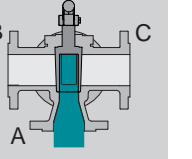
open
 closed

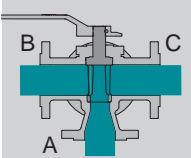
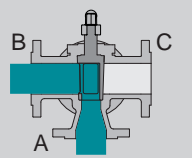
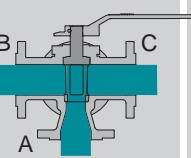
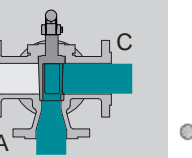
Plug types 4-way (special) and 5-way valves for STANDARD and EXTRA design

Plug type	Pos. I = 0°	Pos. II = 90°	Pos. III = 180°	Pos. IV = 270°	4-way (special) / 5-way
L 	 A B C ✓ A-B ✗ C-D-E	 A B C ✓ A-E ✗ B-C-D	 A B C ✓ A-C ✗ B-D-E	 A B C ✓ A-D ✗ B-C-E	 Type F-4-Special-ISO-STANDARD   Type F-5-ISO-STANDARD 
LL 	 A B C ✓ A-B-E ✗ C-D	 A B C ✓ A-C-E ✗ B-D	 A B C ✓ A-C-D ✗ B-E	 A B C ✓ A-B-D ✗ C-E	
IL 	 A B C ✓ A-E + B-C ✗ D	 A B C ✓ A-C + D-E ✗ B	 A B C ✓ A-D + B-C ✗ E	 A B C ✓ A-B + D-E ✗ C	
T 	 A B C ✓ A-B-C ✗ D-E	 A B C ✓ A-D-E ✗ B-C	 A B C ✓ A-B-C ✗ D-E	 A B C ✓ A-D-E ✗ B-C	
TT 	 A B C ✓ A-B-C-D ✗ E	 A B C ✓ A-B-D-E ✗ C	 A B C ✓ A-B-C-E ✗ D	 A B C ✓ A-C-D-E ✗ B	

 open
 closed